

- \* FOR DIRECT COUPLING
- \* COLOR: MUNSELL RAL 5010
- \* IP55

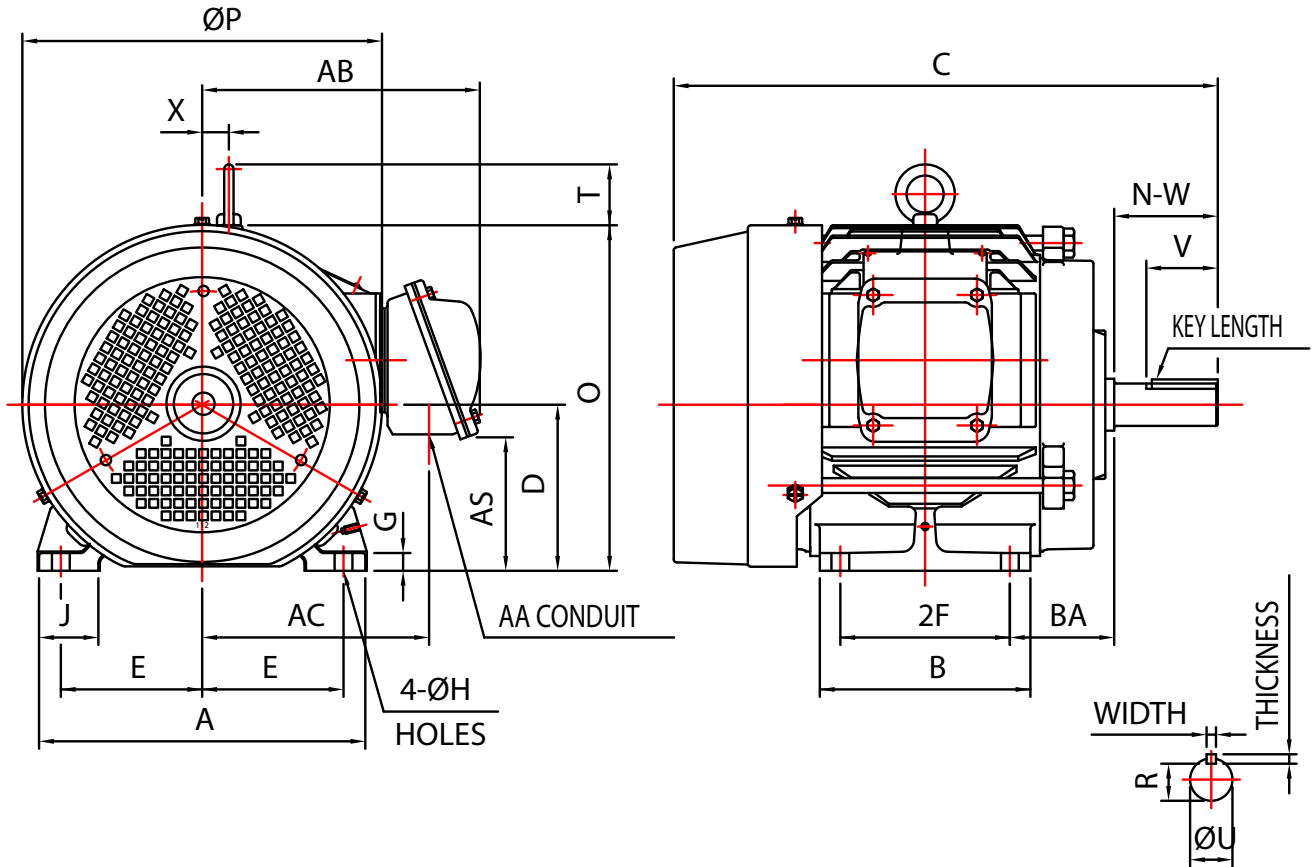

MOUNTING				A	B	C	D	G	J	O	T	P	X
E	2F	H	BA										
3.75	5.50	0.41	2.75	8.66	6.61	15.42	4.50	0.56	1.57	9.27	1.63	9.55	0.71
AC	KEY			KEYSEAT	CONDUIT BOX			SHAFT EXTENSION			BEARING NO.		APR. WT. (LBS.)
	WIDTH	THICKNESS	LENGTH	R	AS	AA	AB	N-W	U	V	D.E	O.D.E	
5.91	0.250	0.250	1.750	0.986	3.71	NPT3/4"	7.32	2.75	1.125	2.70	6207zz	6206zz	120
NOTE:1.TOLERANCE OF SHAFT END DIAMETER U:								+0.000inch,-0.0005inch					
2.TOLERANCE OF SHAFT CENTER HEIGET D:								+0.00inch,-0.03inch					

# 184T Footed