

GROUP	TYPE	FRAME	FORM	'C' DIM	'BS' DIM
01	SC	M56H	K	12.69	6.63
02	SC	U56H	K	12.94	6.88
03	SC	P56H	K	13.94	7.88
04	SC	L56H	K	12.19	6.13

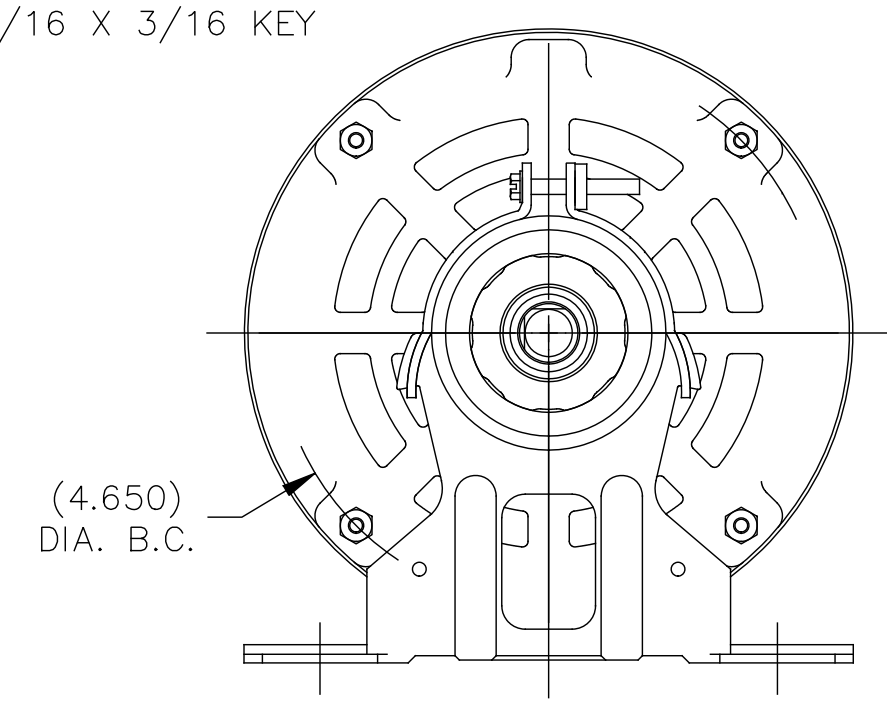
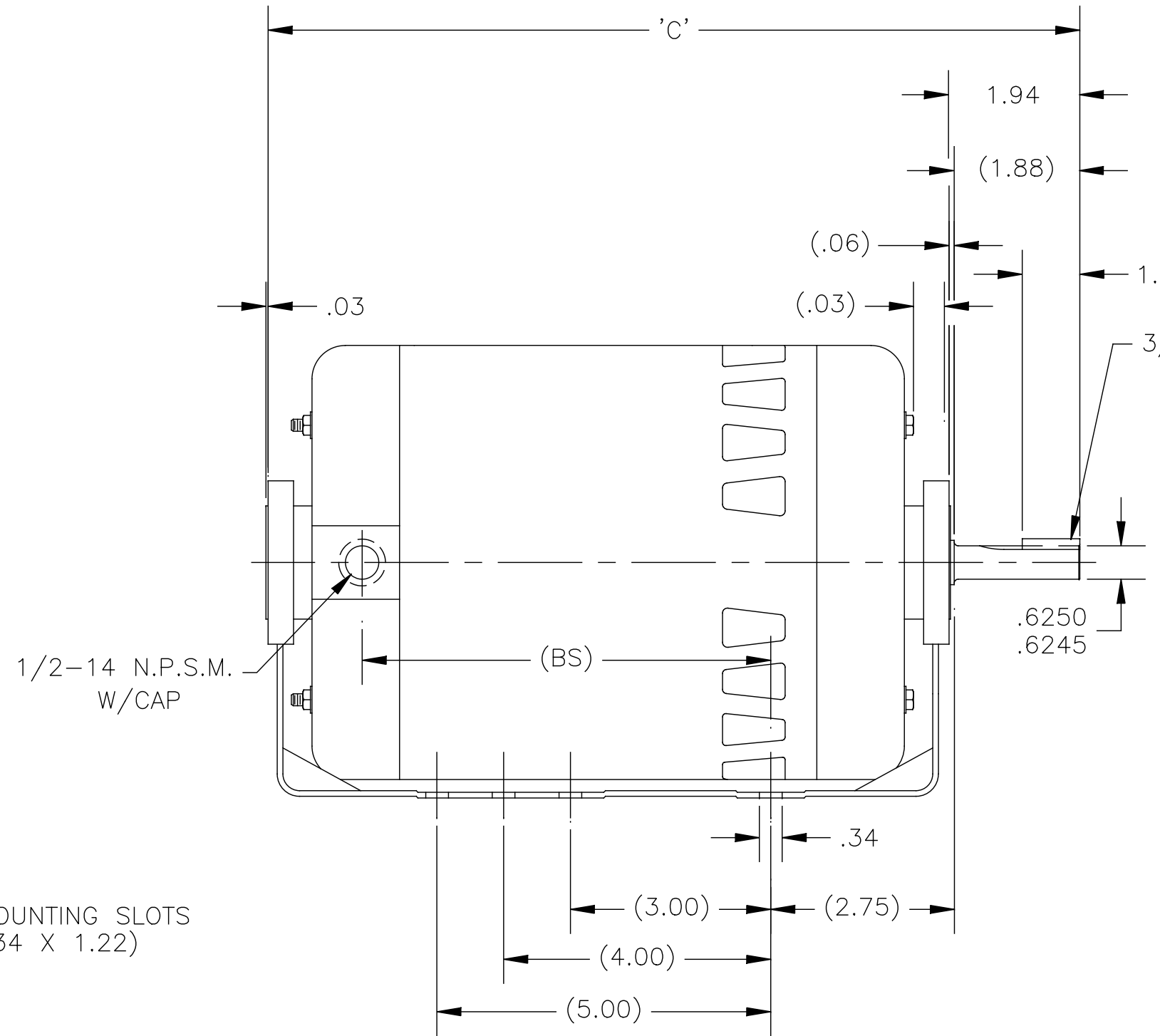
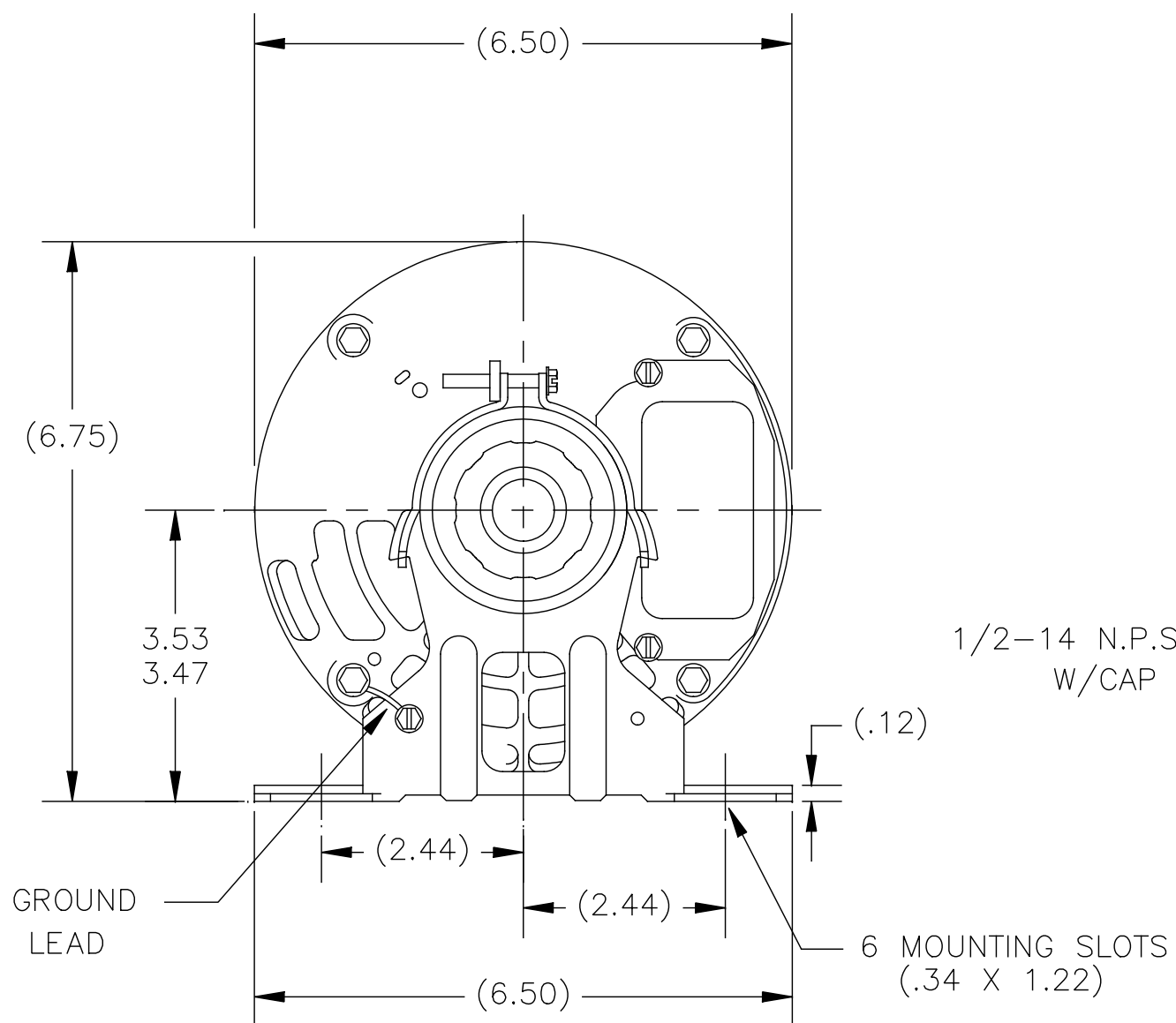

BRACKETS MAY BE OPEN OR ENCLOSED AS REQUIRED ON PROCESS SHEET.

DRAWING REVISION L	REVISION BY A. LITTLEJOHN	DATE 08-08-2016	TOLERANCES UNLESS OTHERWISE SPECIFIED DEC. INCH mm ANGLE .X ±0.1 [±2.5] ±0.5° .XX ±0.02 [±0.51] .XXX ±0.005 [±0.127] .XXXX ±0.0005 [±0.0127]	DRAWN BY:	Regal Beloit America, Inc.
ECO 0098990	APPROVED BY J. HESS	DATE 08-12-2016	REMOVE BURRS & BREAK SHARP EDGES .003/.015 [.076/.381] CORNER FILLETS .02 [.51] MACHINED SURFACES 125/3.2/INCH mm	DATE:	
ECO DESCRIPTION THRUBOLT CHANGE				APPROVED BY:	DESCRIPTION OUTLINE
<small>COPYRIGHT REGAL BELOIT AMERICA, INC. ALL RIGHTS RESERVED. PROPRIETARY AND CONFIDENTIAL INFORMATION - THIS DOCUMENT IS THE PROPERTY OF REGAL BELOIT AMERICA, INC. (OWNER) AND CONTAINS OWNER'S PROPRIETARY INFORMATION. ANY PERSON, CORPORATION OR OTHER FIRM RECEIVING IT IS DEEMED, BY RECEIVING IT, TO AGREE THAT IT, AND/OR ANY PART OF IT, SHALL NOT BE DISCLOSED TO ANY PERSON, CORPORATION OR OTHER ENTITY, DUPLICATED, AND/OR USED, EXCEPT AS EXPRESSLY APPROVED IN WRITING IN ADVANCE BY OWNER. THIS DOCUMENT SHALL BE RETURNED TO OWNER UPON REQUEST. IT MAY BE SUBJECT TO CERTAIN RESTRICTIONS UNDER APPLICABLE EXPORT CONTROL LAWS AND REGULATIONS.</small>				DATE:	MATERIAL
				REFERENCE	PROCESS/FINISH
				THIRD ANGLE PROJECTION	SIZE DWG NO C 161932
					SHEET 1