

FRAME	TYPE
J56	CS

REV	ECO	REV BY	DATE	APPD	DATE
D	ECO-0036530	F.NAVARRO	08-23-2013	T.REYES	08-23-2013

ALL DIMENSIONS SHOWN IN PARENTHESIS ARE REFERENCE DIMENSIONS.

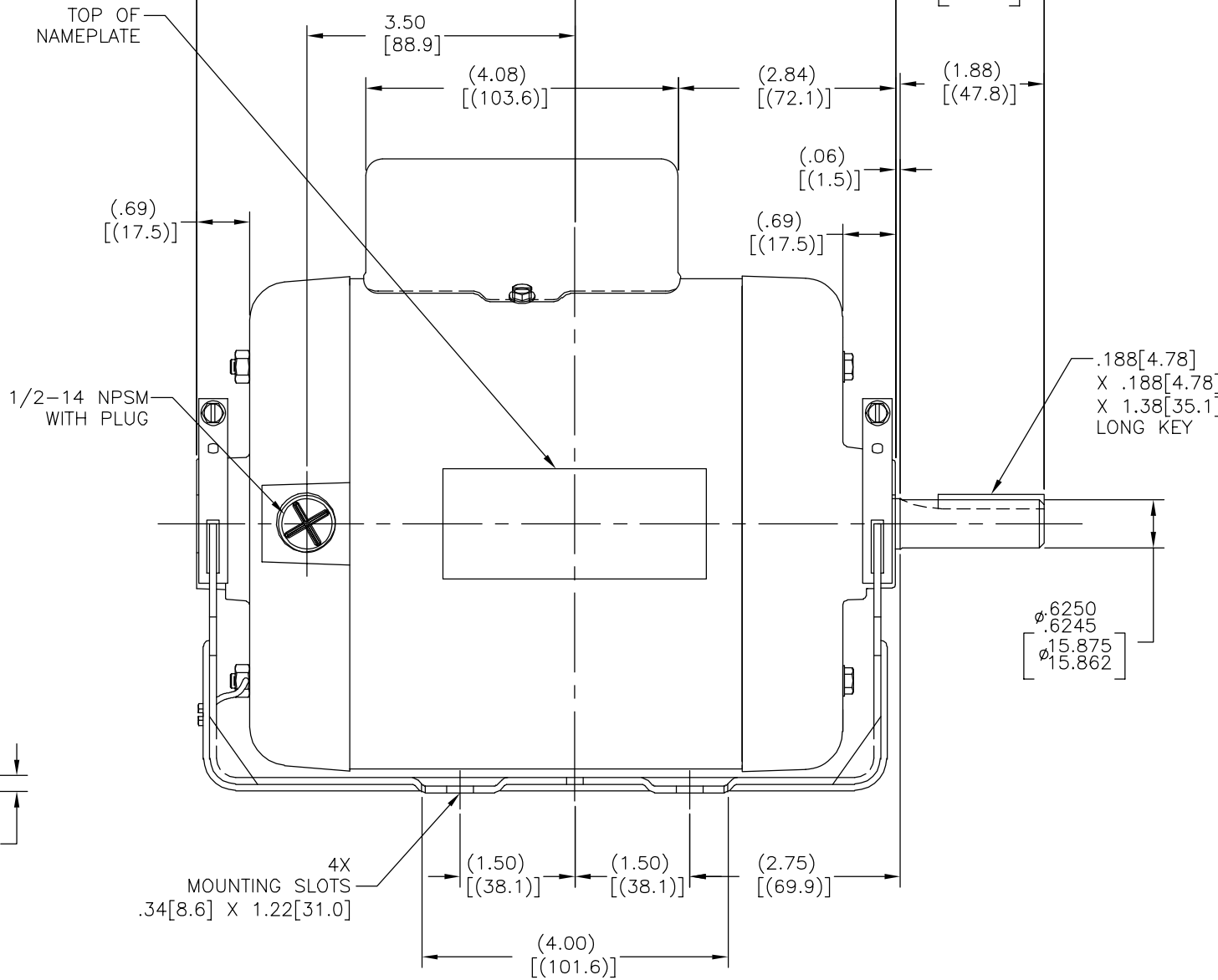
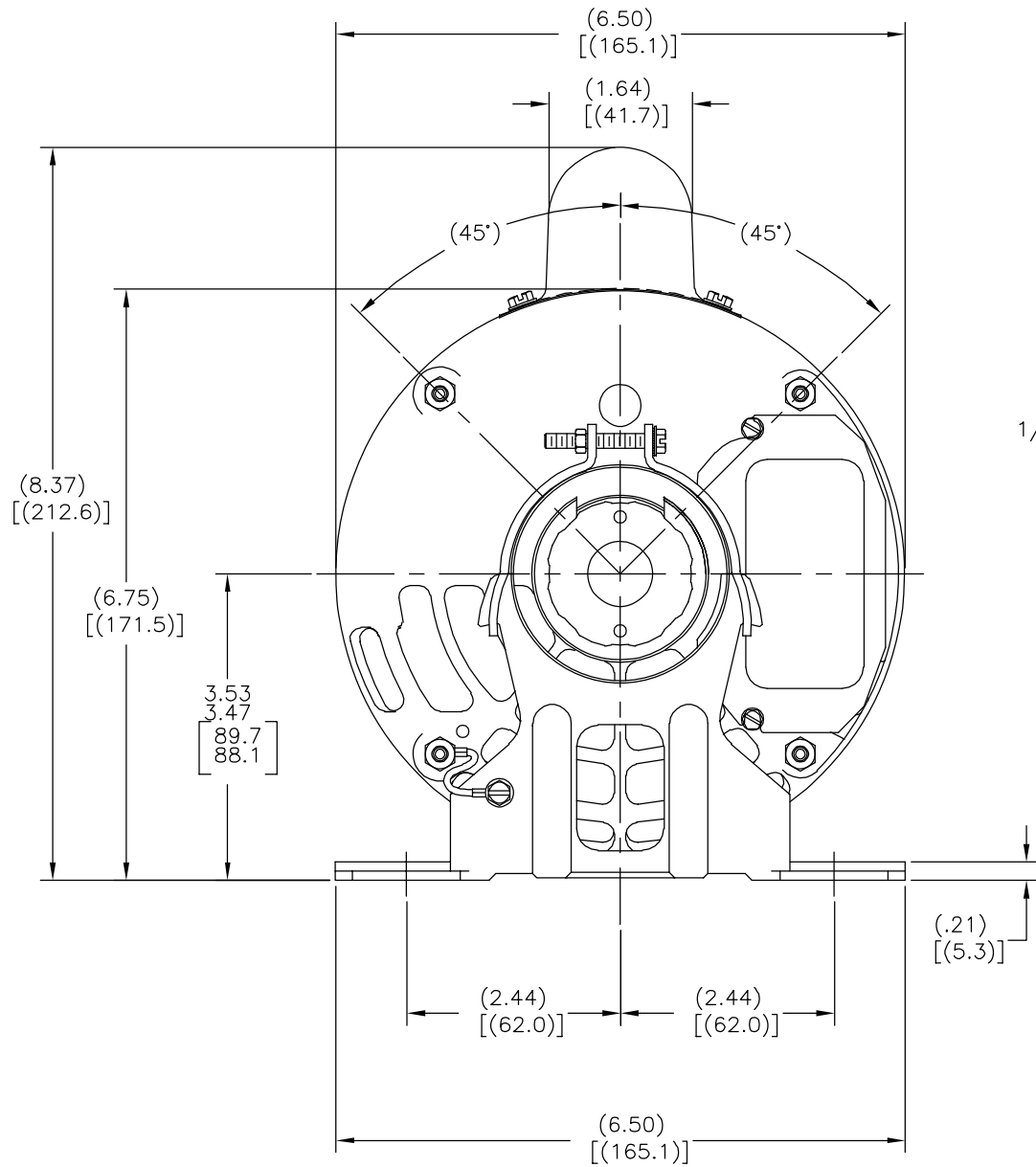

GEOMETRIC CHARACTERISTICS & SYMBOLS

- ▭ FLATNESS
- STRAIGHTNESS
- ∠ ANGULARITY
- ⊥ PERPENDICULARITY (SQUARENESS)
- ∥ PARALLELISM
- ROUNDNESS (CIRCULARITY)
- ⊘ CYLINDRICITY
- △ PROFILE OF ANY SURFACE
- ∩ PROFILE OF ANY LINE
- ↯ RUNOUT
- ⊕ TRUE POSITION
- ◎ CONCENTRICITY
- ≡ SYMMETRY

ASME Y14.5M 1994

UNLESS OTHERWISE SPECIFIED DIM. TOLERANCES ARE AS FOLLOWS:

INCH X XX XXX XXXX  
 mm ±0.5 ±0.13 ±0.005 ±0.005

ANG. ±.50 DEG  
 REMOVE BURRS & BREAK SHARP EDGES:  
 INCH .003-.015 mm 0.1-0.4

CORNER FILLETS TO:  
 INCH .020 mm 0.5

MACHINE SURFACES:  
 INCH 125 mm 3.2

METRIC DIMS. SHOWN IN [BRACKETS]

DR BY:	KAISES	03-04-1965
APPD:		
THIRD ANGLE PROJECTION	EDS DATE 11-11-2011	FORMAT REV H
CONFIDENTIAL: THIS DRAWING AND ITS INFORMATION ARE THE EXCLUSIVE AND CONFIDENTIAL PROPERTY OF REGAL-BELOIT CORPORATION AND ARE NOT TO BE DISCLOSED, DUPLICATED, DISTRIBUTED OR OTHERWISE USED WITHOUT THE WRITTEN CONSENT OF REGAL-BELOIT CORPORATION. -ALL RIGHTS RESERVED.		

<b>REGAL</b> REGAL-BELOIT CORPORATION	
DESCRIPTION MODEL-CFHP-56FR OUTLINE	
SIZE C	DWG NO C666
SCALE NONE	SHEET 1

4

3

2

1

J56	CS
-----	----

REVISION:	ECO	REVISADO POR:	FECHA:	APROBADO POR:	FECHA:
D	ECO-0036530	F.NAVARRO	08-23-2013	T.REYES	08-23-2013

TODAS LAS DIMENSIONES MOSTRADAS ENTRE PARENTESIS SON DE REFERENCIA.

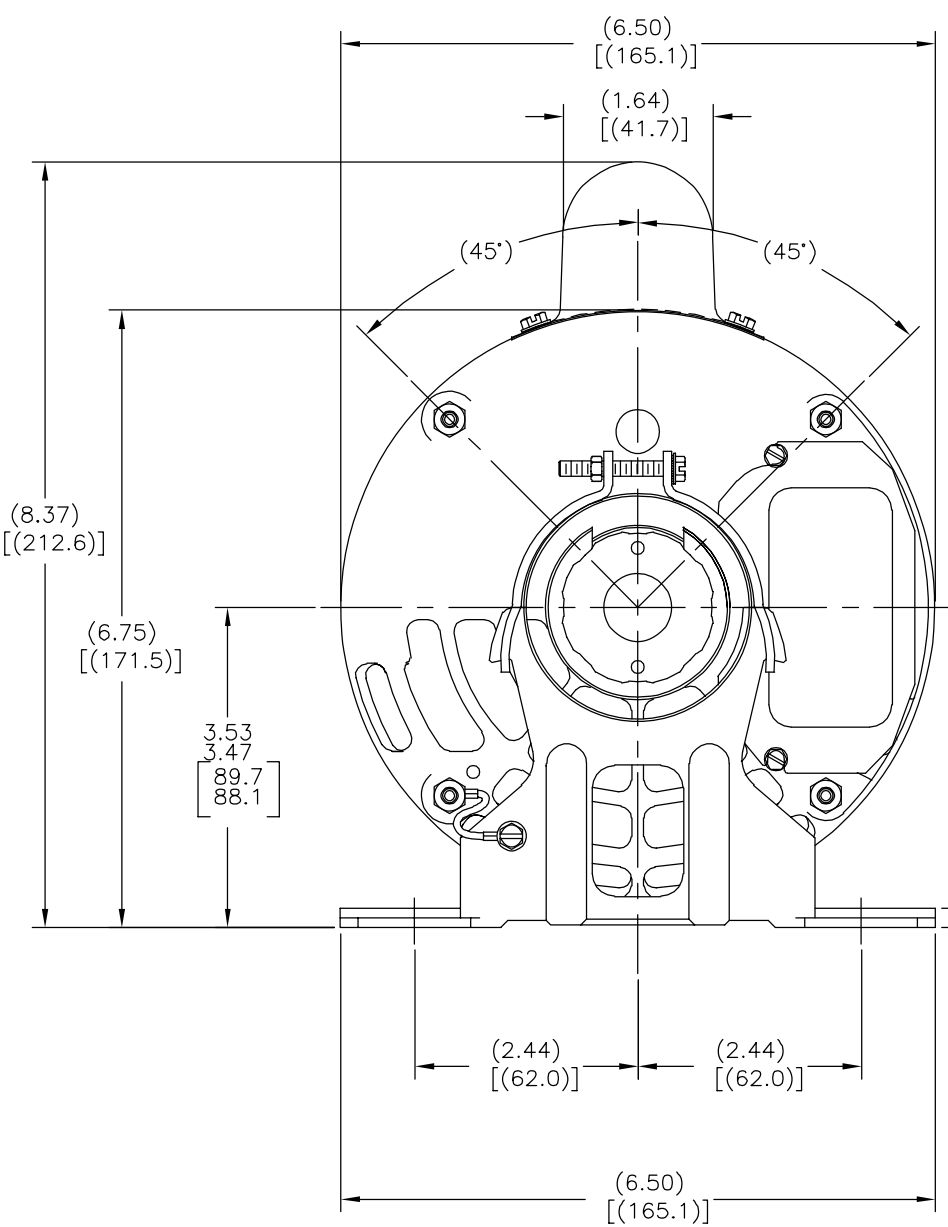

PARTE SUPERIOR DE LA ETIQUETA DE DATOS

1/2-14 NPSM CON TAPON

(.69) [(17.5)]

4X RANURAS DE MONTAJE .34[8.6] X 1.22[31.0]

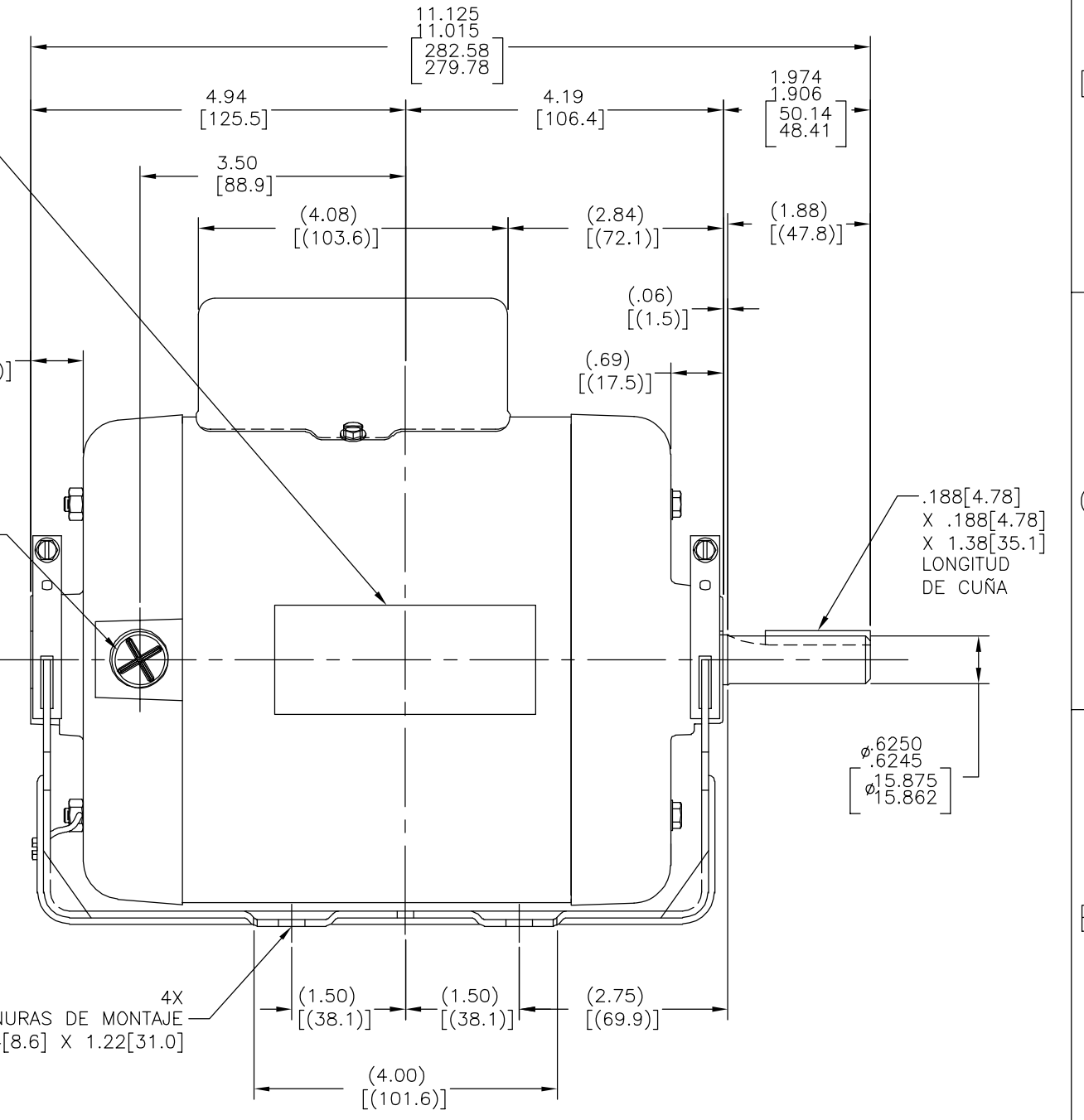

∅ .6250  
.6245  
∅ .15.875  
15.862

A

CARACTERISTICAS DE GEOMETRIA Y SIMBOLOS

- ▧ PLANICIDAD
- RECTITUD
- ∠ ANGULARIDAD
- ⊥ PERPENDICULARIDAD (A ESCUADRA)
- // PARALELISMO
- REDONDEZ (CIRCULARIDAD)
- ∅ CILINDRICIDAD
- △ PERFIL DE CUALQUIER SUPERFICIE
- ∧ PERFIL DE CUALQUIER LINEA
- ∓ VARIACION
- ⊕ POSICION REAL
- ◎ CONCENTRICIDAD
- ≡ SIMETRIA

ASME Y14.5M 1994

A MENOS QUE SE ESPECIFIQUE DE OTRA MANERA, LAS TOLERANCIAS DE LAS DIMS; SON LAS SIGUIENTES:

PULG	±.1	±.02	±.005	±.0005
mm	±0.5	±0.13	±0.013	

ANG. ±50 GRADOS  
ELIMINAR REBABAS Y ORILLAS FILOSAS DEL BORDE.  
PULG .003-.015 mm 0.1-0.4  
FILETEAR ESQUINA: PULG .020 mm 0.5  
MAQUINAR SUPERFICIES  
PULG 125 mm 3.2

DIMS METRICAS MOSTRADAS [PARENTESIS]

DIBUJADO POR:	KAISES	03-04-1965
APROBADO POR:		
TERCER ANGULO DE PROYECCION	⊕	FECHA EDS: 11-11-2011 REV. FORMATO: H

CONFIDENCIAL: ESTE DIBUJO Y SU INFORMACION SON PROPIEDAD DE USO EXCLUSIVO Y CONFIDENCIAL DE REGAL-BELOIT CORPORATION. Y NO DEBERAN SER REVELADOS, DUPLICADOS, DISTRIBUIDOS O USARSE DE OTRA MANERA SIN EL CONSENTIMIENTO ESCRITO DE REGAL-BELOIT CORPORATION. -TODOS LOS DERECHOS RESERVADOS.

<b>REGAL REGAL-BELOIT CORPORATION</b>	
DESCRIPCION: MODEL-CFHP-56FR OUTLINE	
TAMAÑO: C	NUMERO DE DIBUJO: C666
ESCALA: NONE	HOJA: 1

4

3

2

1