

FRAME	TYPE
K56	CS

REV	ECO	REV BY	DATE	APPD	DATE
T	ECO-0025059	J. COX	11-20-2012	C. McREYNOLDS	11-20-2012

ALL DIMENSIONS SHOWN IN PARENTHESIS ARE REFERENCE DIMENSIONS.

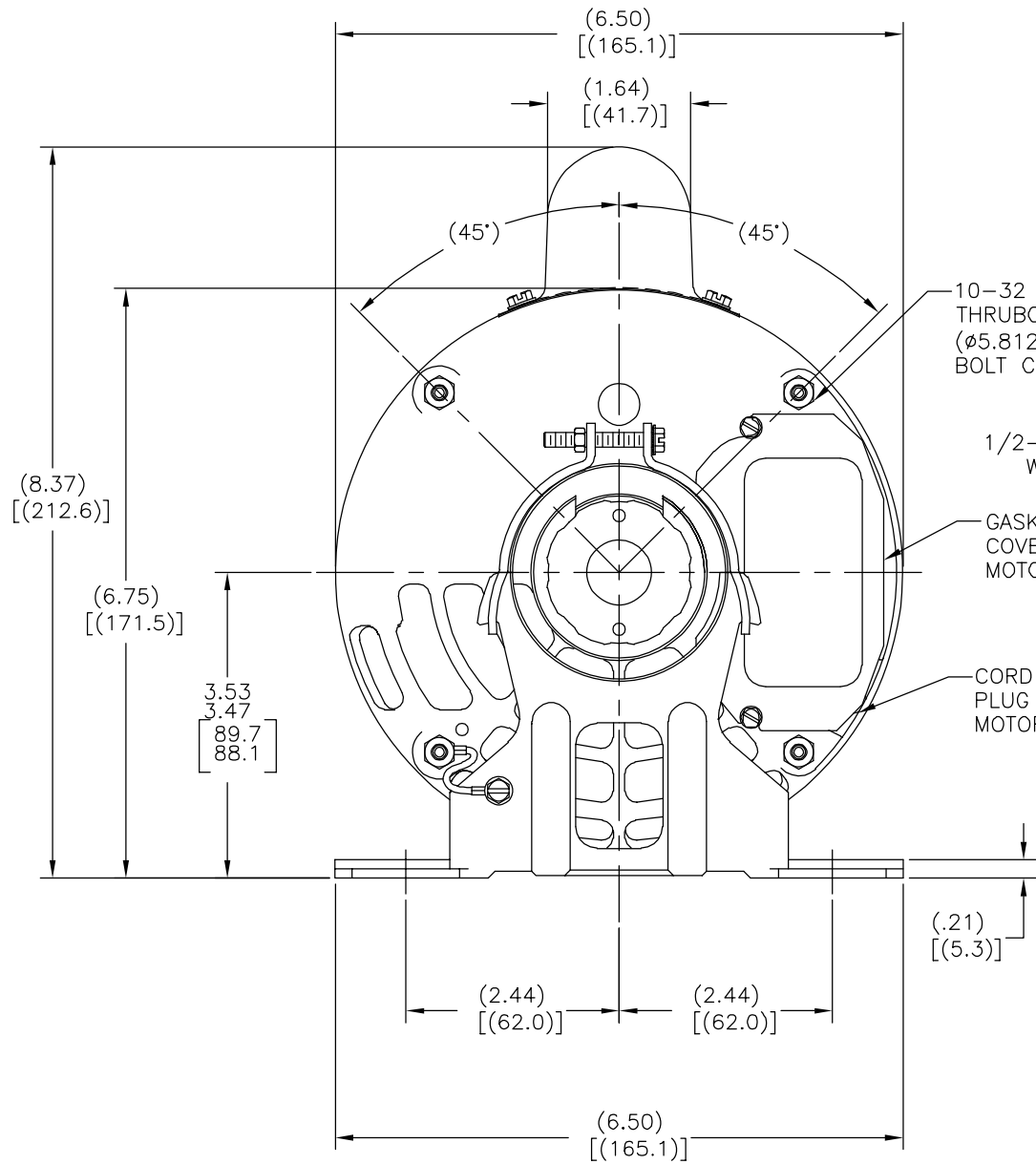

- 10-32 UNF-2A THRU BOLTS ON A (Ø5.812) [(Ø147.62)] BOLT CIRCLE
- 1/2-14 NPSM WITH PLUG
- GASKETS UNDER COVER FOR ENCL MOTORS ONLY
- CORD HOLE PLUG FOR ENCL MOTORS ONLY

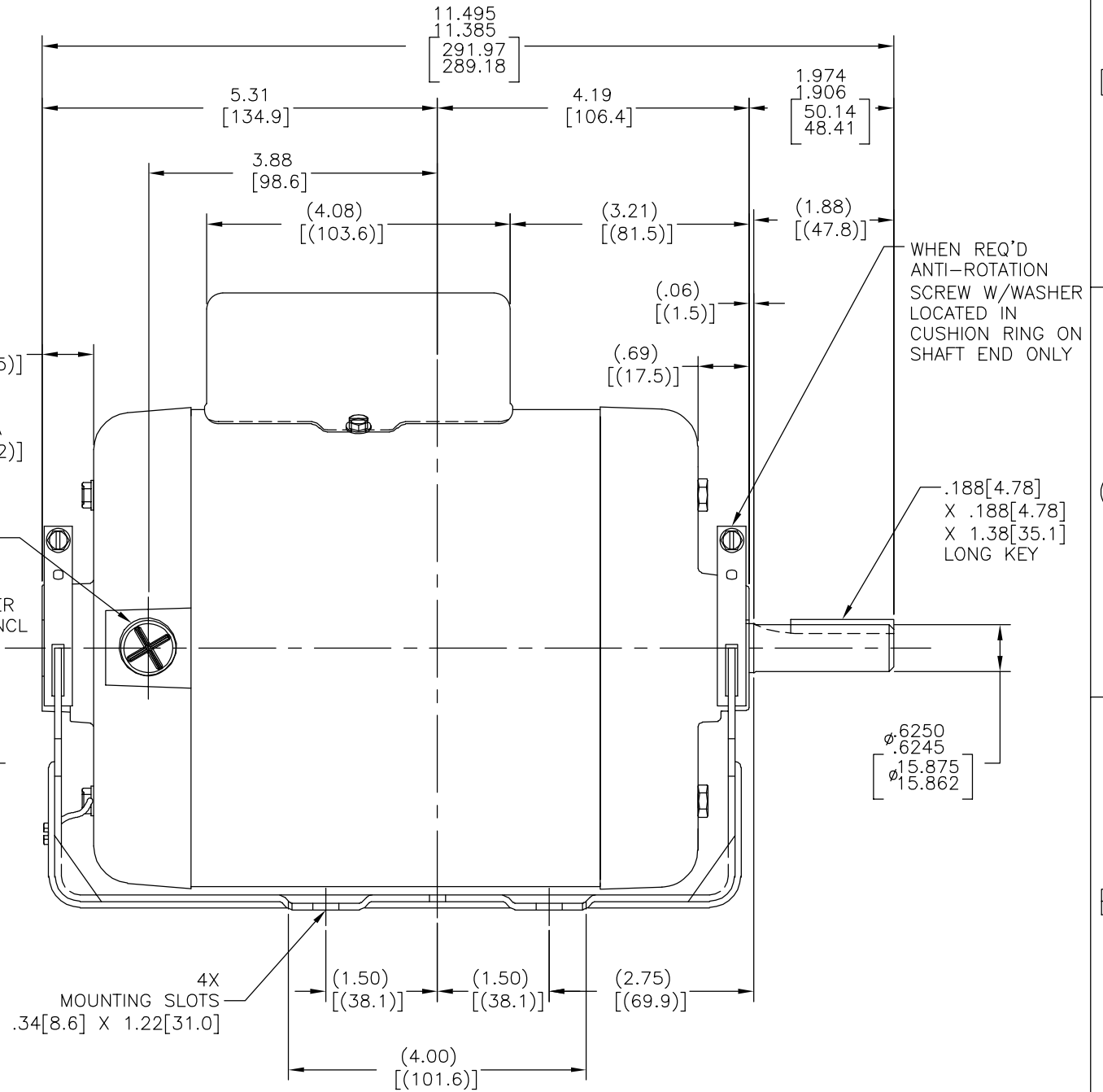

WHEN REQ'D ANTI-ROTATION SCREW W/WASHER LOCATED IN CUSHION RING ON SHAFT END ONLY

GEOMETRIC CHARACTERISTICS & SYMBOLS

- FLATNESS
- STRAIGHTNESS
- ∠ ANGULARITY
- ⊥ PERPENDICULARITY (SQUARENESS)
- // PARALLELISM
- ROUNDNESS (CIRCULARITY)
- ⊘ CYLINDRICITY
- △ PROFILE OF ANY SURFACE
- ∩ PROFILE OF ANY LINE
- ↯ RUNOUT
- ⊕ TRUE POSITION
- ◎ CONCENTRICITY
- ≡ SYMMETRY

ASME Y14.5M 1994

UNLESS OTHERWISE SPECIFIED DIM. TOLERANCES ARE AS FOLLOWS:

INCH X XX XXX XXXX  
 mm ±0.5 ±0.13 ±0.013

ANG. ±.50 DEG  
 REMOVE BURRS & BREAK SHARP EDGES:  
 INCH .003-.015 mm 0.1-0.4

CORNER FILLETS TO:  
 INCH .020 mm 0.5

MACHINE SURFACES:  
 INCH 125 mm 3.2

METRIC DIMS. SHOWN IN [BRACKETS]

DR BY:	KAISES	03-04-1965
APPD:		
THIRD ANGLE PROJECTION	EDS DATE 11-11-2011	FORMAT REV H
CONFIDENTIAL: THIS DRAWING AND ITS INFORMATION ARE THE EXCLUSIVE AND CONFIDENTIAL PROPERTY OF REGAL-BELOIT CORPORATION AND ARE NOT TO BE DISCLOSED, DUPLICATED, DISTRIBUTED OR OTHERWISE USED WITHOUT THE WRITTEN CONSENT OF REGAL-BELOIT CORPORATION. -ALL RIGHTS RESERVED.		

<b>REGAL REGAL-BELOIT CORPORATION</b>	
DESCRIPTION	
MODEL-CFHP-56FR OUTLINE	
SIZE	DWG NO
C	C231
SCALE	SHEET
NONE	1

4

3

2

1

REVISION:	ECO	REVISADO POR:	FECHA:	APROBADO POR:	FECHA:
T	ECO-0025059	J. COX	11-20-2012	C. McREYNOLDS	11-20-2012

K56	CS
-----	----

TODAS LAS DIMENSIONES MOSTRADAS ENTRE PARENTESIS SON DE REFERENCIA.

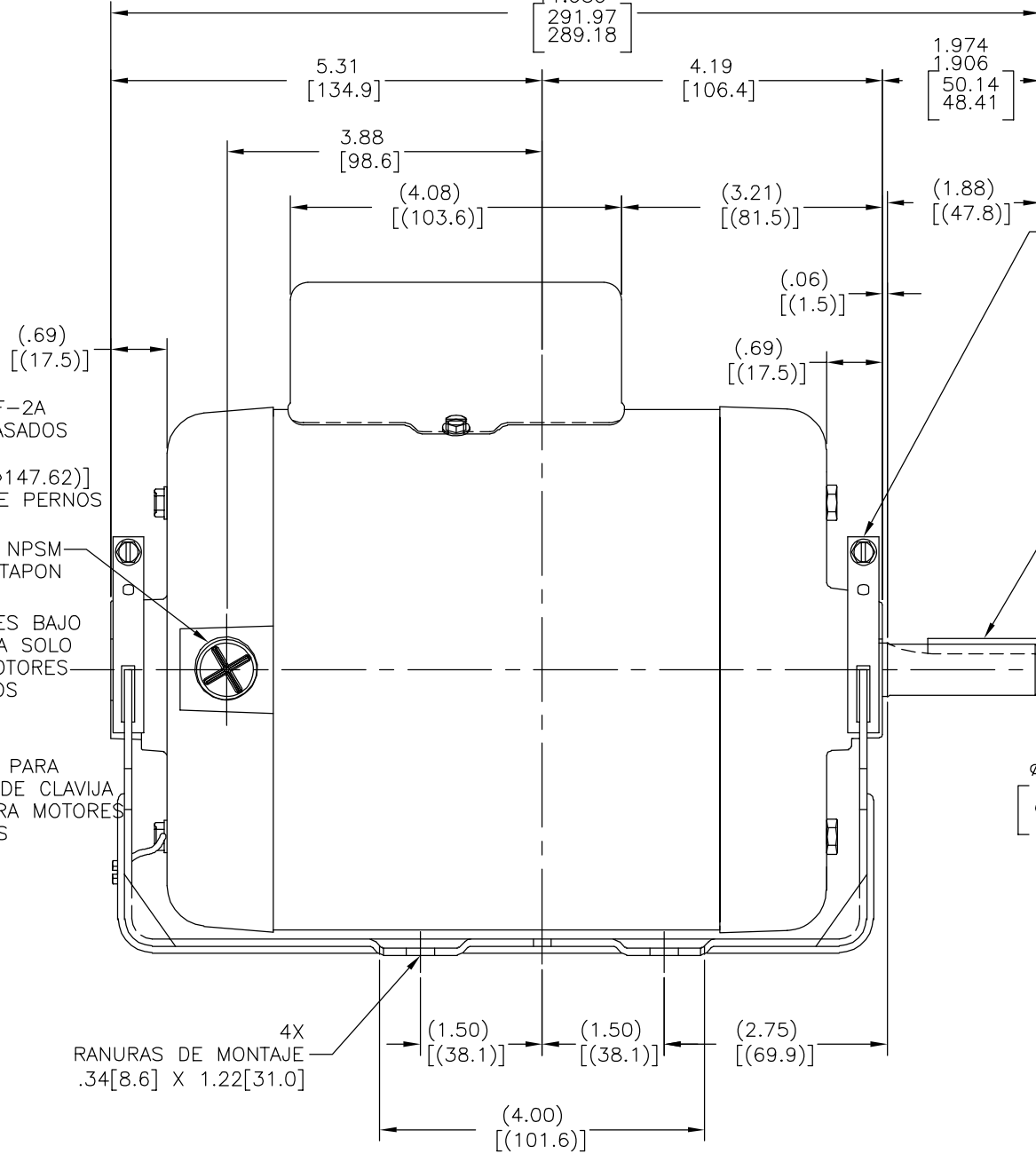
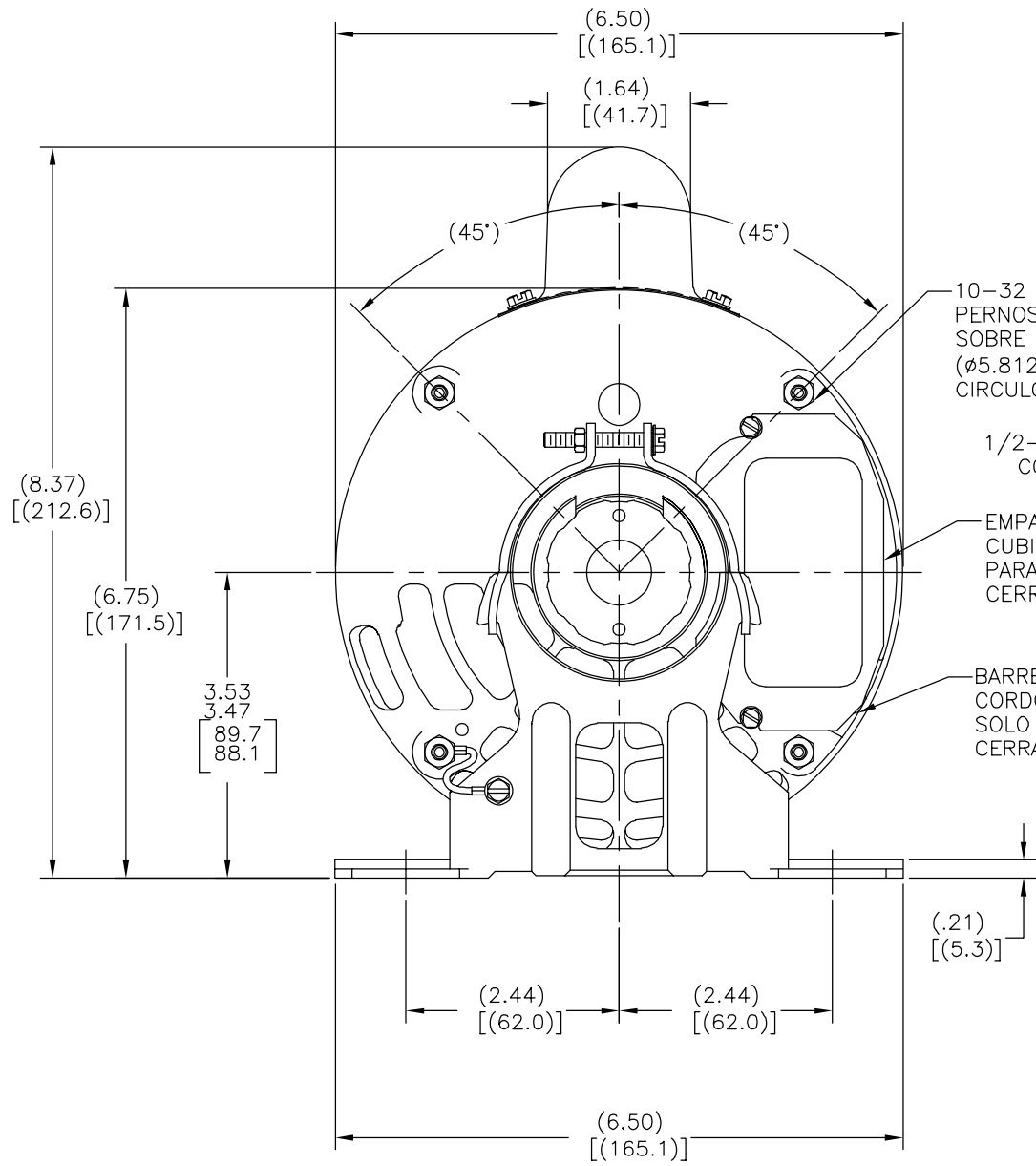

CARACTERISTICAS DE GEOMETRIA Y SIMBOLOS

- ∠ PLANICIDAD
- RECTITUD
- ∠ ANGULARIDAD
- ⊥ PERPENDICULARIDAD (A ESCUADRA)
- // PARALELISMO
- REDONDEZ (CIRCULARIDAD)
- ∅ CILINDRICIDAD
- △ PERFIL DE CUALQUIER SUPERFICIE
- ∩ PERFIL DE CUALQUIER LINEA
- ∩ VARIACION
- ⊕ POSICION REAL
- ◎ CONCENTRICIDAD
- = SIMETRIA

ASME Y14.5M 1994

A MENOS QUE SE ESPECIFIQUE DE OTRA MANERA, LAS TOLERANCIAS DE LAS DIMS; SON LAS SIGUIENTES:

PULG ±.1 ±.02 ±.005 ±.0005  
 mm ±0.5 ±0.13 ±0.013

ANG. ± 50 GRADOS

ELIMINAR REBABAS Y ORILLAS FILOSAS DEL BORDE.

PULG .003-.015 mm 0.1-0.4  
 FILETEAR ESQUINA: PULG .020 mm 0.5  
 MAQUINAR SUPERFICIES  
 PULG 125 mm 3.2

DIMS METRICAS MOSTRADAS [PARENTESIS]

DIBUJADO POR: KAISES 03-04-1965

APROBADO POR:

TERCER ANGULO DE PROYECCION

FECHA EDS: 11-11-2011  
 REV. FORMATO: H

CONFIDENCIAL: ESTE DIBUJO Y SU INFORMACION SON PROPIEDAD DE USO EXCLUSIVO Y CONFIDENCIAL DE REGAL-BELOIT CORPORATION. Y NO DEBERAN SER REVELADOS, DUPLICADOS, DISTRIBUIDOS O USARSE DE OTRA MANERA SIN EL CONSENTIMIENTO ESCRITO DE REGAL-BELOIT CORPORATION. -TODOS LOS DERECHOS RESERVADOS.

**REGAL REGAL-BELOIT CORPORATION**

DESCRIPCION: MODEL-CFHP-56FR OUTLINE

TAMAÑO: C NUMERO DE DIBUJO: C231

ESCALA: NONE HOJA: 1

4

3

2

1