

GENERAL INFORMATION:

SHAFT RUNOUT: .001 [.03] T.I.R. PER INCH LENGTH OF EXTENSION
 END PLAY: .010 TO .063 [.25 TO 1.60]
 BEARINGS: SLEEVE
 MOUNTING POSITION: HORIZONTAL
 ELECTRICAL DATA:
 OVERLOAD PROTECTOR: AUTOMATIC RESET (SENSATA 7AM 036)
 LEADS: NO. 18 GA., .03 [.8] THK. XLP 125°C INSUL.
 REVERSING PLUGS: NO. 18 GA., .03 [.8] THK. XLP 125°C INSUL.
 GROUND LEAD: NO. 18 GA., .03 [.8] THK. (GREEN) INSUL.

NOTES:
 1. ● DENOTES CRITICAL CHARACTERISTICS.
 2. (4) SPLIT RING ADAPTOR 615035 (OR 53P26-1 ONLY USED IN MEXICO), (8) SCREWS 615982-001, (1) 2518746-001 CLAMP AND (1) CAPACITOR 2509074-001 TO BE PUT IN A POLYBAG & BE PACKED WITH EACH MOTOR.

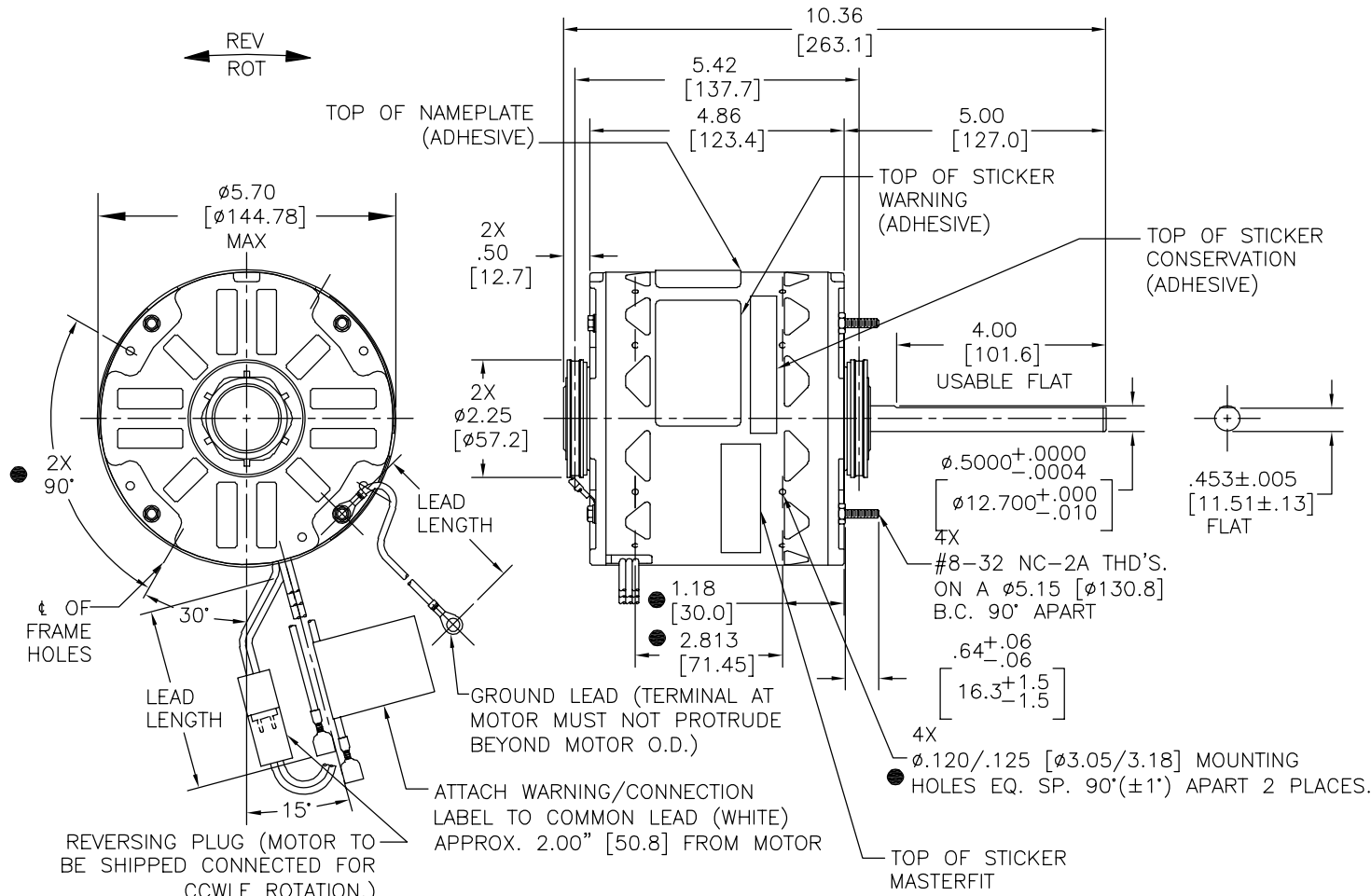

NAMEPLATE DATA:

MODEL NO.: F48AE74A01
 CUST. P/N: 7FD6000A
 HP: 1/2-1/6
 ROT.: REVERSIBLE
 RPM: 1075/4 SPD.
 TYPE: UF
 FRAME: 48Y
 VOLTS: 277
 PH: 1
 AMPS: 3.3 MAX.
 HZ: 60
 INS.: B
 AMB.: 40° C
 DUTY: AIR OVER
 CAP.: 10 OR 5 MFD/370 V
 ENCL: OPEN
 UL LOGO
 CSA LOGO
 THERMALLY PROTECTED

EXTERNAL CONNECTION DIAGRAM

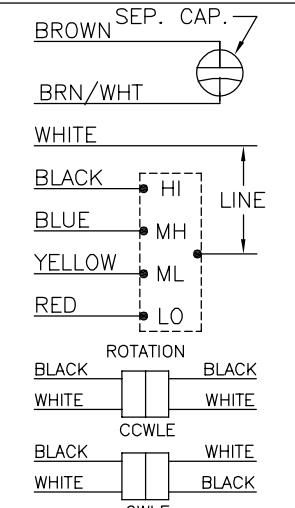

GREEN (GROUND)	9.0/11.0 [229/279]	.25 [6.4] RING
BLACK/WHITE	3.0/5.0 [76/127]	REVERSING PLUG
BROWN	36.5/39.5 [927/1003]	.25[6.4] FEMALE
BROWN/WHITE	36.5/39.5 [927/1003]	.25[6.4] FEMALE
RED	36.5/39.5 [927/1003]	.25[6.4] FEMALE
YELLOW	36.5/39.5 [927/1003]	.25[6.4] FEMALE
BLUE	36.5/39.5 [927/1003]	.25[6.4] FEMALE
BLACK	36.5/39.5 [927/1003]	.25[6.4] FEMALE
WHITE	36.5/39.5 [927/1003]	.25[6.4] FEMALE
COLOR	LENGTH	TERMINAL OR STRIP LENGTH

MAIN FRAME - OLE	OPEN
END FRAME - OLE	OPEN
MAIN FRAME - LE	OPEN
END FRAME - LE	OPEN

CUSTOMER	DISTRIBUTION SERVICE
----------	----------------------

REGAL-BELOIT CORPORATION (RBC) PROVIDES TECHNICAL ASSISTANCE TO OUR CUSTOMERS IN SEVERAL AREAS. SINCE RBC DOES NOT RECEIVE ALL DATA CONCERNING THE USE AND APPLICATION OF THE MOTOR, THE SUITABILITY OF THE MOTOR FOR THE APPLICATION MUST BE DETERMINED BY THE CUSTOMER.
 DIMENSIONS WITHOUT TOLERANCES ARE FOR REFERENCE ONLY.

PERFORMANCE CURVE NO.	TORQUE @1075 RPM (25°C)	APPROVED SAMPLE	UL COMPONENT	CSA
C0000683	55.4 OZ. FT.	X-0004053	E46412 PRGY2	LR43341 4211-01

DRAWING REVISION	REVISION BY	DATE
C	G.ZHAO	05-09-2014
ECO	APPROVED BY	DATE
0050471	C.ZHOU	05-09-2014
ECO DESCRIPTION SEE ECO		

COPYRIGHT REGAL-BELOIT AMERICA, INC. ALL RIGHTS RESERVED. PROPRIETARY AND CONFIDENTIAL INFORMATION - THIS DOCUMENT IS THE PROPERTY OF REGAL-BELOIT AMERICA, INC. (OWNER) AND CONTAINS OWNER'S PROPRIETARY INFORMATION. ANY PERSON, CORPORATION OR OTHER FIRM RECEIVING IT IS DEEMED, BY RECEIVING IT, TO AGREE THAT IT AND/OR ANY PART OF IT, SHALL NOT BE DISCLOSED TO ANY PERSON, CORPORATION OR OTHER ENTITY, DUPLICATED, AND/OR USED, EXCEPT AS EXPRESSLY APPROVED IN WRITING IN ADVANCE BY OWNER. THIS DOCUMENT SHALL BE RETURNED TO OWNER UPON REQUEST. IT MAY BE SUBJECT TO CERTAIN RESTRICTIONS UNDER APPLICABLE EXPORT CONTROL LAWS AND REGULATIONS.

DRAWN BY:	G.ZHAO	DATE:	05-09-2014
APPROVED BY:	C.ZHOU	DATE:	05-09-2014
REFERENCE:		MATERIAL:	
THIRD ANGLE PROJECTION	SIZE DWG NO	7FD6000A	SHEET 1

REGAL™ Regal Beloit America, Inc.
 DESCRIPTION MODEL-RFHP-48FR
 OUTLINE