

4

3

2

1

CUSTOMER IS SOLELY RESPONSIBLE FOR MOTOR PERFORMANCE AND SUITABILITY IN APPLICATIONS FOR CUSTOMER'S USES.

REV	ECO	REV BY	DATE	APPD	DATE
F	0029021	E.SINECIO	10-18-2012	G.ALVIDREZ	10-18-2012

END PLAY .005[.13] MIN - .040[1.02] MAX
 MAX. SHAFT RUN OUT .001[.02] PER INCH
 MAX. RUN OUT NOT TO EXCEED .010[.25]

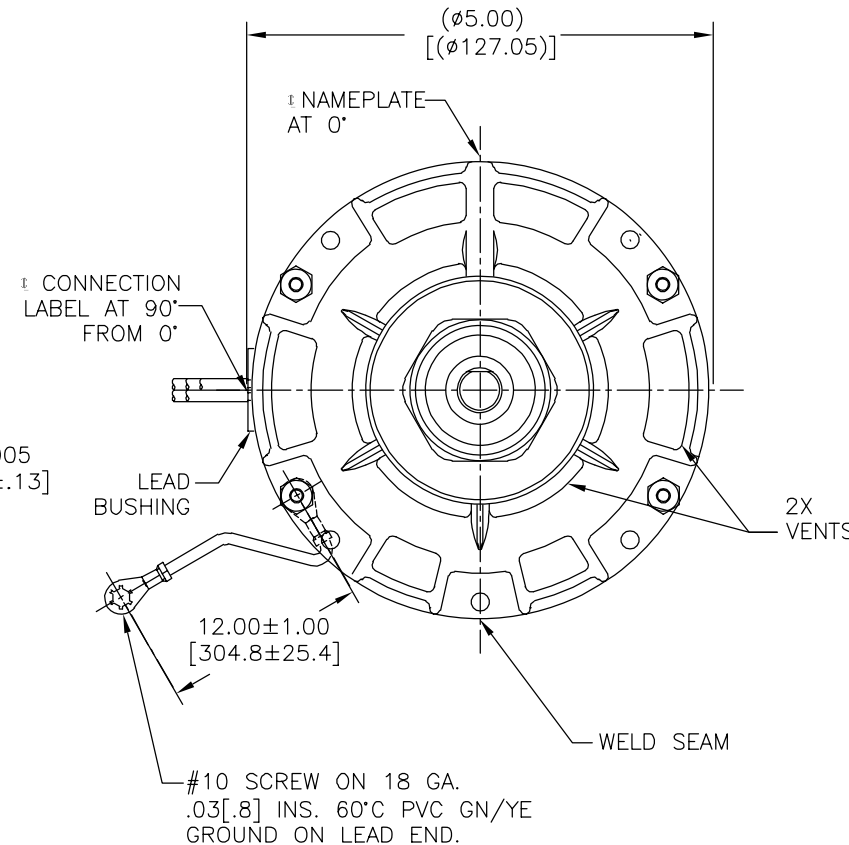
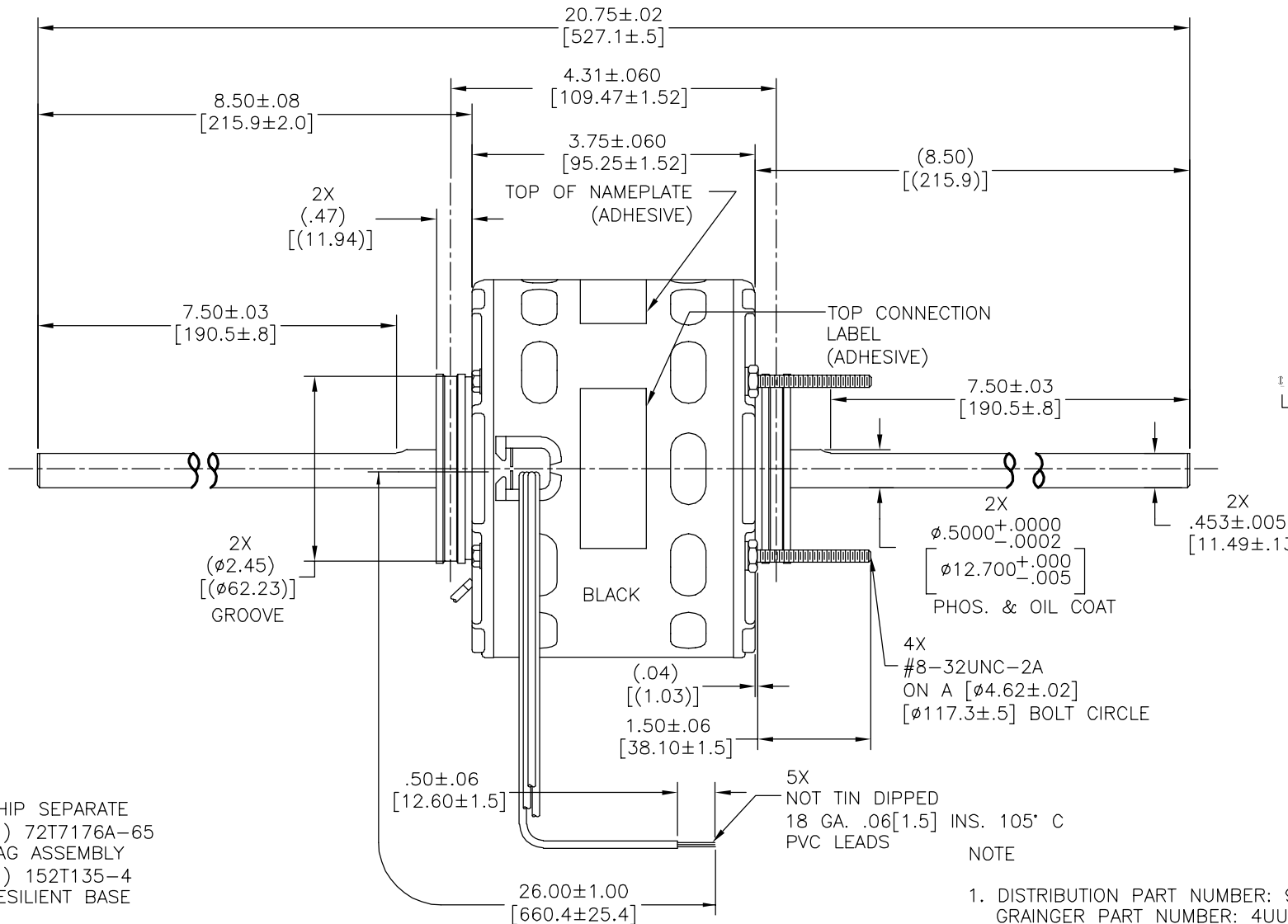

SHIP SEPARATE
 (1) 72T7176A-65 BAG ASSEMBLY
 (1) 152T135-4 RESILIENT BASE

ELECTRICALLY PER SAMPLE 0442632C CURVE C32374

SCHMATIC-281

ROT.: - CCWLE

NAMEPLATE DATA:



Tipp City, OH
 THERMALLY PROTECTED



SER. DATE & P0# PLT LTR MOD DA3D222N"
 VOLTS 115 HZ 60 AMPS 2.0
 RPM 1050 SP 4 PH 1 CAP
 INS CL B AMB40°C HP 1/35 CONT. A.O. ← ROTATION →
 BRG SLV ASSEMBLED IN MEXICO

CONN. LABEL
 2514721-001

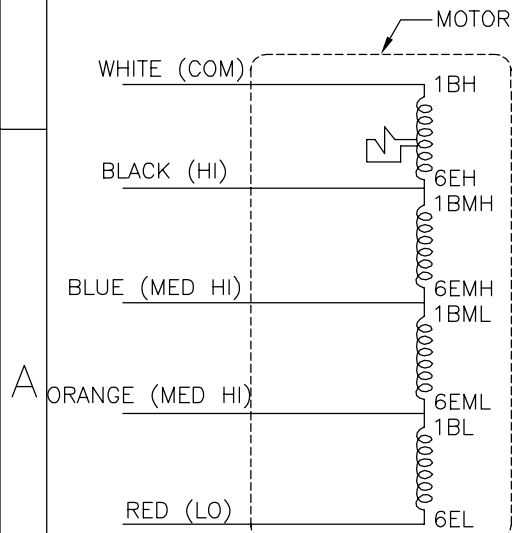

GEOMETRIC CHARACTERISTICS & SYMBOLS
 ▽ FLATNESS
 - STRAIGHTNESS
 < ANGLARITY
 ⊥ PERPENDICULARITY (SQUARENESS)
 ∥ PARALLELISM
 ○ ROUNDNESS (CIRCULARITY)
 ⌀ CYLINDRICITY
 △ PROFILE OF ANY SURFACE
 ▽ PROFILE OF ANY LINE
 ↗ RUNOUT
 ⊕ TRUE POSITION
 ⊙ CONCENTRICITY
 = SYMMETRY
 ASME Y14.5M 1994

REGAL-BELOIT CORPORATION (RBC) PROVIDES TECHNICAL ASSISTANCE TO OUR CUSTOMERS IN SEVERAL AREAS. SINCE RBC DOES NOT RECEIVE ALL DATA CONCERNING THE USE AND APPLICATION OF THE MOTOR, THE SUITABILITY OF THE MOTOR FOR THE APPLICATION MUST BE DETERMINED BY THE CUSTOMER.

DIMENSIONS WITHOUT TOLERANCES ARE FOR REFERENCE ONLY.

DR BY: J.RUPERT 09-29-2004
 APPD: G.PIATT 09-29-2004
 THIRD ANGLE PROJECTION
 EDS DATE 11-11-2011
 FORMAT REV H
 CONFIDENTIAL: THIS DRAWING AND ITS INFORMATION ARE THE EXCLUSIVE AND CONFIDENTIAL PROPERTY OF REGAL-BELOIT CORPORATION AND ARE NOT TO BE DISCLOSED, DUPLICATED, DISTRIBUTED OR OTHERWISE USED WITHOUT THE WRITTEN CONSENT OF REGAL-BELOIT CORPORATION. -ALL RIGHTS RESERVED.



DESCRIPTION
 MODEL-RFHP-42FR
 OUTLINE
 SIZE C DWG NO 9673
 SCALE NONE SHEET 1

4

3

2

1

4

3

2

1

EL CLIENTE ES SOLO RESPONSABLE DEL RENDIMIENTO DEL MOTOR Y APLICACIONES CONVENIENTES PARA LOS USOS DEL CLIENTE.

REVISION:	ECO	REVISADO POR:	FECHA:	APROBADO POR:	FECHA:
F	0029021	E.SINECIO	10-18-2012	G.ALVIDREZ	10-18-2012

JUEGO AXIAL .005[.13] MIN - .040[1.02] MAX
 MAX. OSCILAMIENTO DE FLECHA .001[.02] POR PULGADA
 MAX. OSCILAMIENTO NO EXCEDERA DE .010[.25]

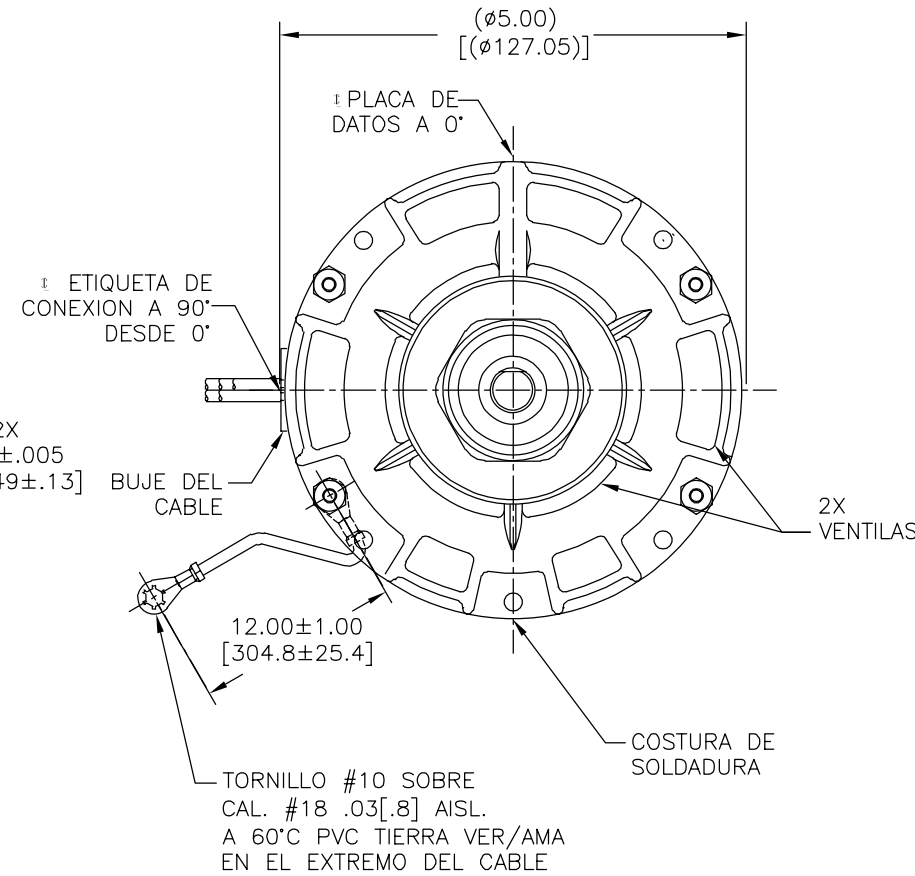
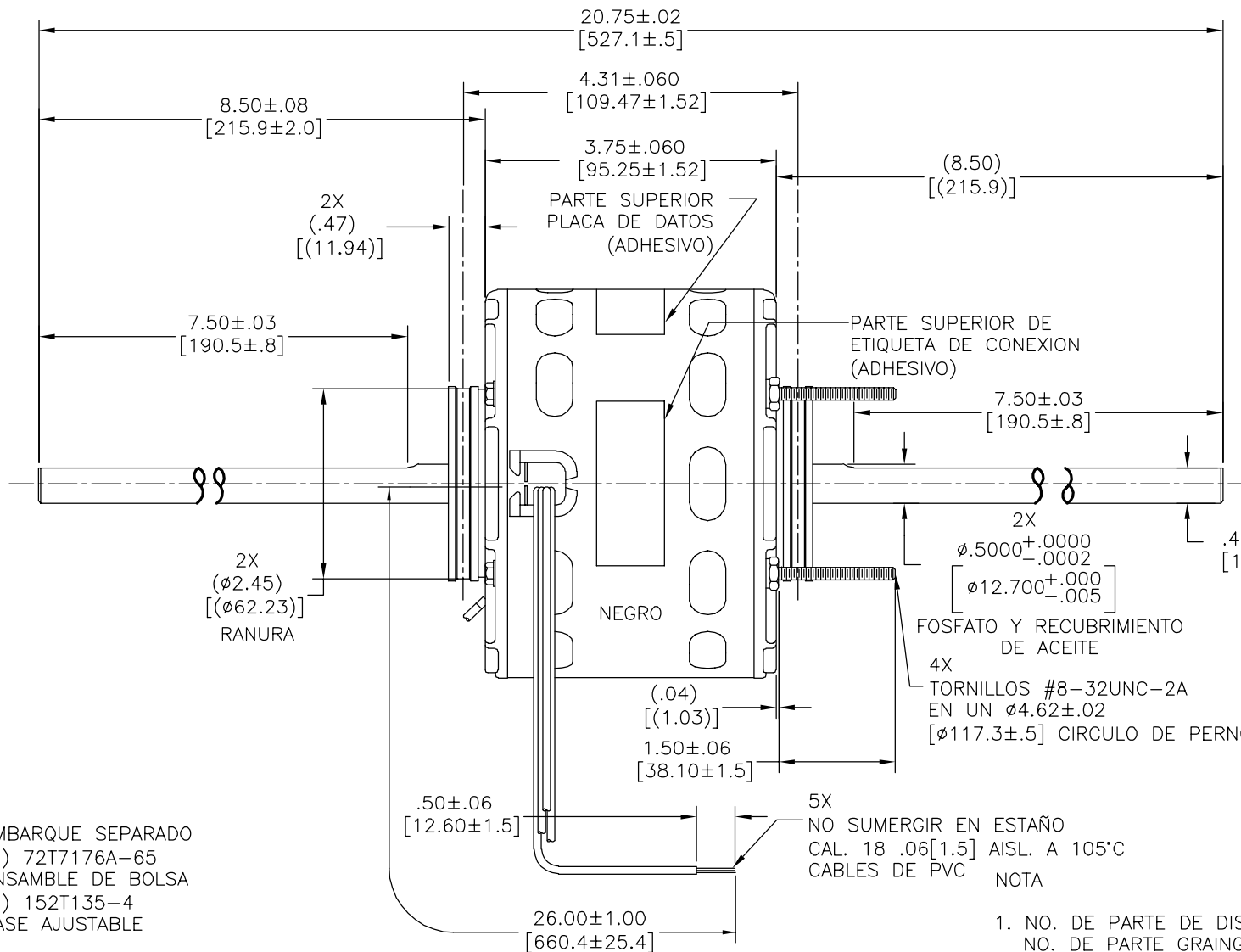

EMBARQUE SEPARADO
 (1) 72T7176A-65 ENSAMBLE DE BOLSA
 (1) 152T135-4 BASE AJUSTABLE

1. NO. DE PARTE DE DISTRIBUCION: 9673
 NO. DE PARTE GRAINGER: 4UU46

ELECTRICAMENTE DE ACUERDO A MUESTRA 0442632C CURVA DE FUNCIONAMIENTO C32374

ESQUEMA-281

ROT.: - CCWLE

PLACA DE DATOS:



Tipp City, OH
 THERMALLY PROTECTED



SER. DATE & P0# PLT LTR MOD DA3D222N"
 VOLTS 115 HZ 60 AMPS 2.0
 RPM 1050 SP 4 PH 1 CAP
 INS CL B AMB40°C HP 1/35 CONT. A.O. ←ROTATION→
 BRG SLV ASSEMBLED IN MEXICO

ETIQUETA DE CONEXION
 2514721-001

CARACTERISTICAS DE GEOMETRIA Y SIMBOLOS
 ▽ PLANICIDAD
 - RECTITUD
 < ANGULARIDAD
 ⊥ PERPENDICULARIDAD (A ESCUADRA)
 // PARALELISMO
 ○ REDONDEZ (CIRCULARIDAD)
 ∅ CILINDRICIDAD
 △ PERFIL DE CUALQUIER SUPERFICIE
 ∩ PERFIL DE CUALQUIER LINEA
 ∠ VARIACION
 ⊕ POSICION REAL
 ⊙ CONCENTRICIDAD
 = SIMETRIA
 ASME Y14.5M 1994

REGAL-BELOIT CORPORATION (RBC) PROVEE ASISTENCIA TECNICA A NUESTROS CLIENTES EN VARIAS AREAS. DESDE QUE RBC NO RECIBE TODOS LOS DATOS EN RELACION AL USO Y A LA APLICACION DEL MOTOR, LA APLICACION ADECUADA DEL MOTOR DEBE SER DETERMINADA POR EL CLIENTE.

DIMENSIONES SIN TOLERANCIA SON DE REFERENCIA SOLAMENTE

DIBUJADO POR: J.RUPERT 09-29-2004
 APROBADO POR: G.PIATT 09-29-2004
 TERCER ANGULO DE PROYECCION
 FECHA EDS: 11-11-2011
 REV. FORMATO: H
 CONFIDENCIAL: ESTE DIBUJO Y SU INFORMACION SON PROPIEDAD DE USO EXCLUSIVO Y CONFIDENCIAL DE REGAL-BELOIT CORPORATION. Y NO DEBERAN SER REVELADOS, DUPLICADOS, DISTRIBUIDOS O USARSE DE OTRA MANERA SIN EL CONSENTIMIENTO ESCRITO DE REGAL-BELOIT CORPORATION. -TODOS LOS DERECHOS RESERVADOS.

REGAL REGAL-BELOIT CORPORATION

DESCRIPCION:
 MODEL-RFHP-42FR
 OUTLINE

TAMAÑO: C NUMERO DE DIBUJO: 9673

ESCALA: NONE HOJA: 1

4

3

2

1

4

3

2

1

版本	ECO	编制	日期	批准	日期
F	0029021	E.SINECIO	10-18-2012	G.ALVIDREZ	10-18-2012

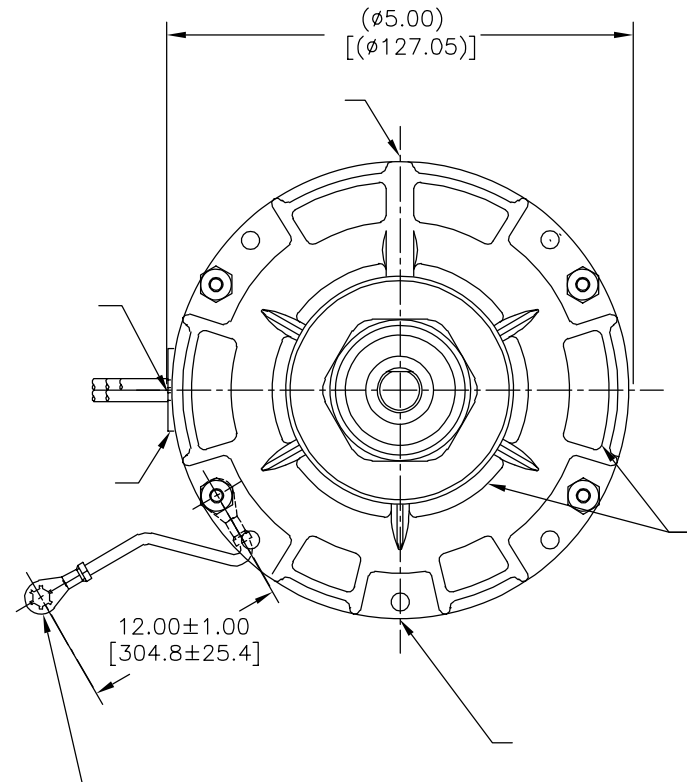
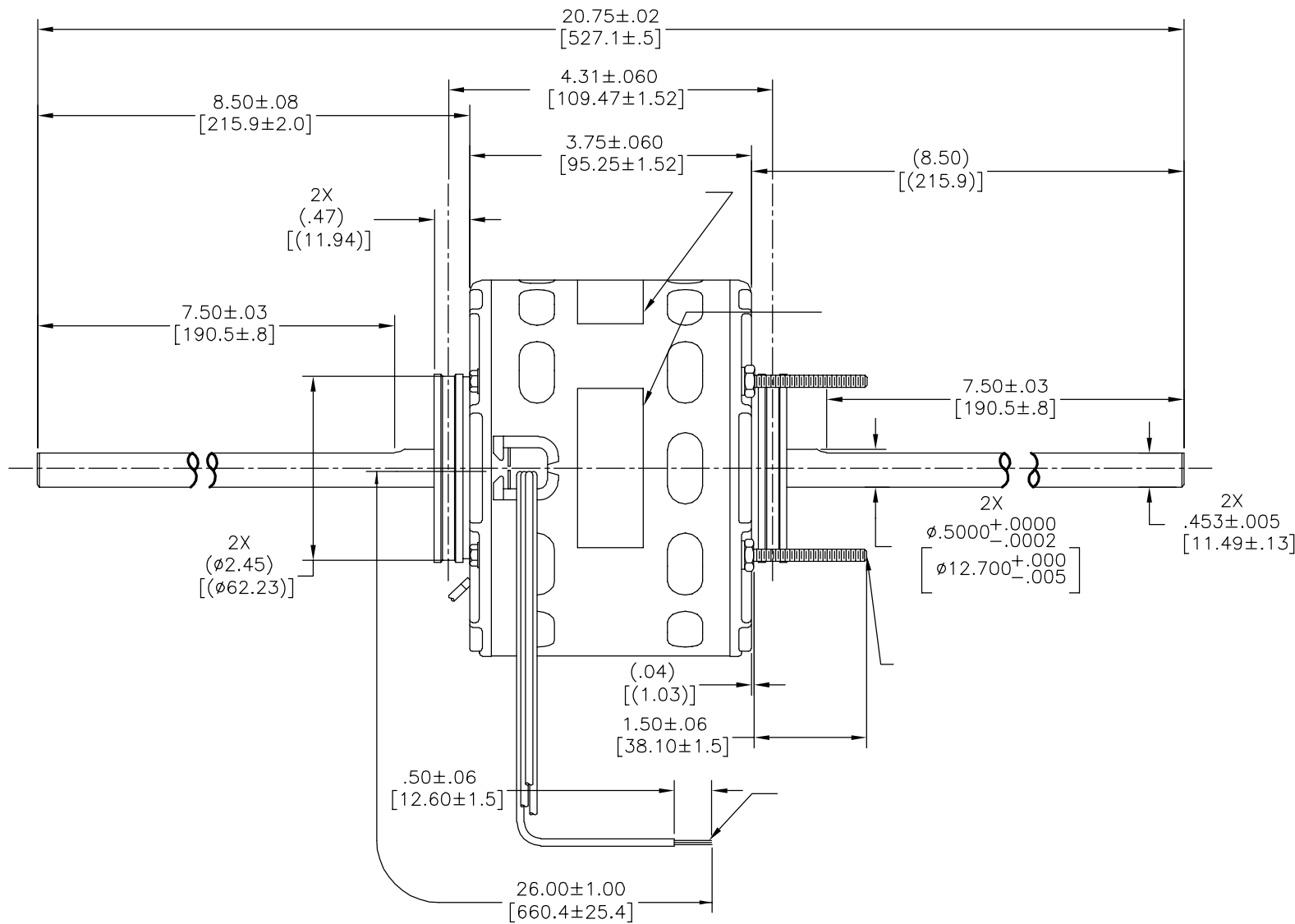

ROT.:— CCWLE



Tipp City, OH
THERMALLY PROTECTED



SER. DATE & P0# PLT LTR MOD DA3D222N"
VOLTS 115 HZ 60 AMPS 2.0
RPM 1050 SP 4 PH 1 CAP
INS CL B AMB40°C HP 1/35 CONT. A.O. ←ROTATION→
BRG SLV ASSEMBLED IN MEXICO

2514721-001

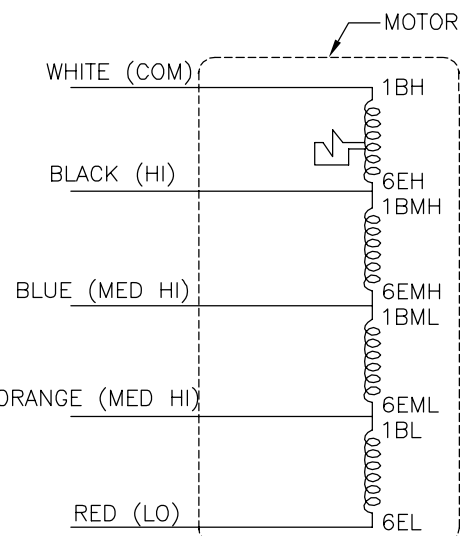

- 形位公差
- 平面度
- 直线度
- ∠ 倾斜度
- ⊥ 垂直度
- // 平行度
- 圆度
- ⊙ 圆柱度
- ⌒ 面轮廓度
- ⌒ 线轮廓度
- ↻ 圆跳动
- ⊕ 位置度
- ⊗ 同轴度
- ≡ 对称度

ASME Y14.5M 1994

REGAL-BELOIT CORPORATION (RBC) 在个别领域为客户
提供技术支持。鉴于RBC
未收到任何涉及电机使用和
应用环境的数据，电机的适用性
由客户自己决定。

未注公差尺寸仅供参考。

绘图:	J.RUPERT	09-29-2004
批准:	G.PIATT	09-29-2004
第三角投影		图纸格式发布日期 11-11-2011 图纸格式版本 H
机密: 本图纸及相关信息所有权归REGAL-BELOIT CORPORATION。 未经REGAL-BELOIT CORPORATION书面授权，不得泄露、 复制、传播或作其他用途。—版权所有		

REGAL REGAL-BELOIT CORPORATION

名称
MODEL-RFHP-42FR
OUTLINE

图幅 C 图号 9673

比例 NONE 页号 1

4

3

2

1