



WORLDWIDE ELECTRIC MOTOR DATA SHEET

EP30-12-326TC



HORSEPOWER	30		
RPM / POLES	1200 / 6		
VOLTAGE / PHASE	230 / 460 V / 3		
FRAME	326TC		
ENCLOSURE / DEGREE OF PROTECTION	TEFC / IP55		
FREQUENCY	60 HZ Suitable For 50 HZ Operation With 1.0 SF		
FULL LOAD SPEED	1185 RPM		
SERVICE FACTOR	1.25 SF at 40° C / 1.0 SF at 55° C		
INSULATION CLASS	F		
FULL LOAD AMPS; 230 / 460	77.6 / 38.8 A		
LOCKED ROTOR AMPS (STARTING); 230 / 460	435 / 218 A		
NO LOAD CURRENT	37.0 / 18.5 A		
NEMA CODE LETTER	G		
EFFICIENCY / POWER FACTOR	<u>LOAD</u>	<u>EFF.</u>	<u>P.F.</u>
	100%	93.0%	0.78
	75%	92.0%	0.73
	50%	89.6%	0.71
DUTY CYCLE	S1 / Continuous		
TORQUE	<u>FULL LOAD</u>	<u>LRT</u>	<u>BDT</u>
	133.0 lb.ft.	210%	260%
SLIP	1.25%		
NEMA DESIGN	B		
MOMENT OF INERTIA	12.941 lb.ft.²		
NUMBER OF STARTS (Hot / Cold)	2 Hot / 3 Cold		
MAX. AMBIENT TEMPERATURE	40° C at 1.25 SF / 55° C at 1.0 SF		
MAX. ELEVATION	3300 Ft. Above Sea Level		
TEMPERATURE RISE (At Full Load)	80° C		
DE BEARING	6312		
ODE BEARING	6312		
GREASE TYPE	Mobil Polyrex EM		
MOUNTING	F1 (F2 Suitable)		
ROTATION	Bi-Directional		
APPROXIMATE WEIGHT	660 lbs.		
AREA CLASSIFICATION	Class I, Division 2, Groups A, B, C, D		
INVERTER RATING	10:1 CT / 20:1 VT PWM Type		
SPECIFICATION - In Accordance With	NEMA, CSA		



CC067A



MARCH 10, 2015



WORLDWIDE ELECTRIC MOTOR DRAWING

EP-326TC

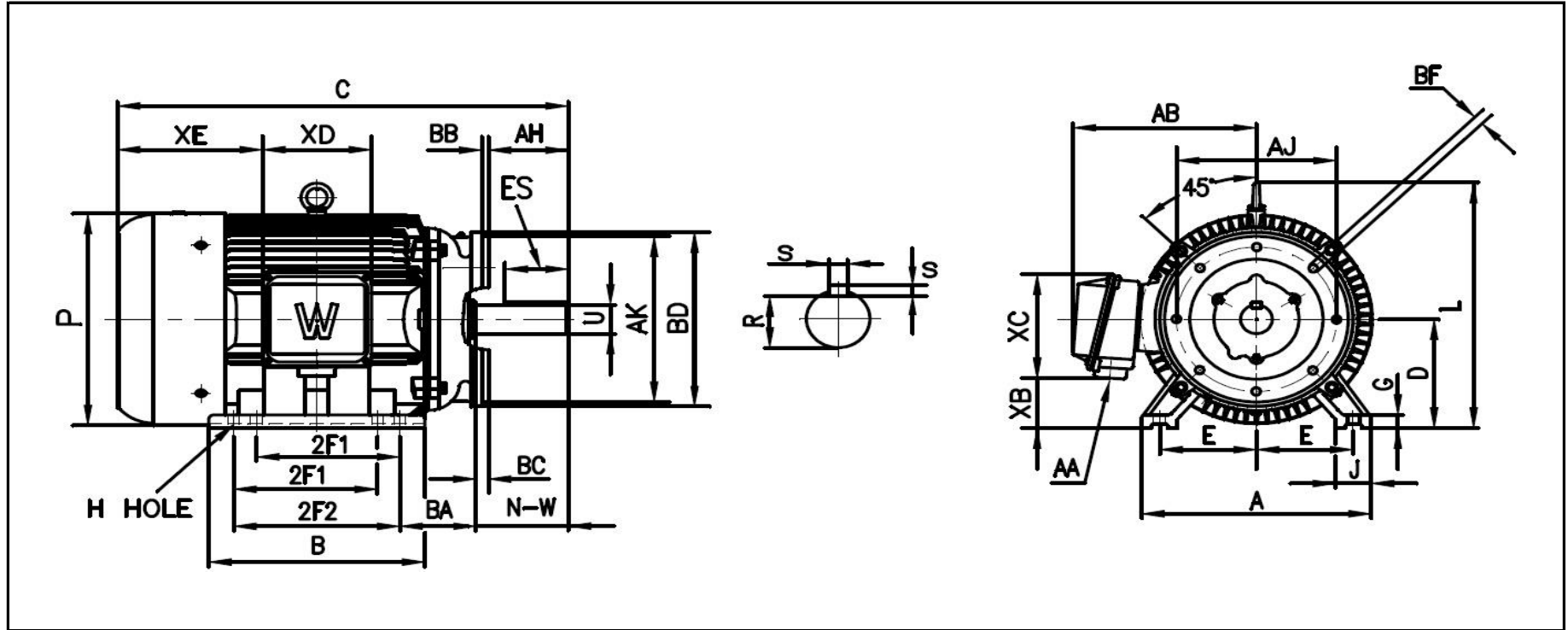

DIMENSIONS - INCHES

MOUNTING					A	B	C	D	G	J	P	L	AB	AH	BC
E	2F1	2F2	H	BA											
6.25	10.5	12	0.66	5.25	15.3	14	30.9	8	0.984	2.76	16.57	18.25	14.17	5	0.25

KEY		KEYSET	FLANGE				SHAFT		TERMINAL BOX					
S	ES	R	AK	AJ	BF	BB	BD	N-W	U	AA	XB	XC	XD	XE
0.5	3.91	1.845	12.5	11	5/8-11	0.25	13.78	5.25	2.125	3	2.64	10.55	8.98	10.47