



WORLDWIDE ELECTRIC MOTOR DATA SHEET

IXPEWWE10-18-215T



HORSEPOWER	10		
RPM / POLES	1800 / 4		
VOLTAGE / PHASE	230 / 460 V / 3		
FRAME	215T		
ENCLOSURE / DEGREE OF PROTECTION	TEFC / IP55		
FREQUENCY	60 HZ Suitable For 50 HZ Operation With 1.0 SF		
FULL LOAD SPEED	1772 RPM		
SERVICE FACTOR	1.15 SF		
INSULATION CLASS	F		
FULL LOAD AMPS	24.4 / 12.2 A		
LOCKED ROTOR AMPS (STARTING)	162 / 81 A		
NO LOAD CURRENT			
NEMA CODE LETTER	H		
EFFICIENCY / POWER FACTOR	<u>LOAD</u>	<u>EFF.</u>	<u>P.F.</u>
	100%	91.7%	0.86
	75%	92.0%	0.86
	50%	90.0%	0.78
DUTY CYCLE	S1 / Continuous		
TORQUE	<u>FULL LOAD</u>	<u>LRT</u>	<u>BDT</u>
	29.8 lb.ft.	165%	200%
SLIP	1.56%		
NEMA DESIGN	B		
MOMENT OF INERTIA			
NUMBER OF STARTS (Hot / Cold)	1 Hot / 2 Cold (Per Hour)		
MAX. AMBIENT TEMPERATURE	40° C		
MAX. ELEVATION	3300 Ft. Above Sea Level		
TEMPERATURE RISE (At Full Load)	80° C		
DE BEARING	6308-ZZ		
ODE BEARING	6308-ZZ		
GREASE TYPE	Mobil Polyrex EM		
MOUNTING	F1		
ROTATION	Bi-Directional		
APPROXIMATE WEIGHT	262 lbs.		
TEMPERATURE CODE AT 40°C AMBIENT	T3C		
TEMPERATURE CODE AT 55°C AMBIENT	T3C		
AREA CLASSIFICATION	Class I, Division I, Groups C & D		
	Class II, Division I, Groups F & G		
INVERTER RATING	5:1 CT / 10:1 VT PWM Type		





WORLDWIDE ELECTRIC MOTOR DRAWING

IXPEWWE-215T

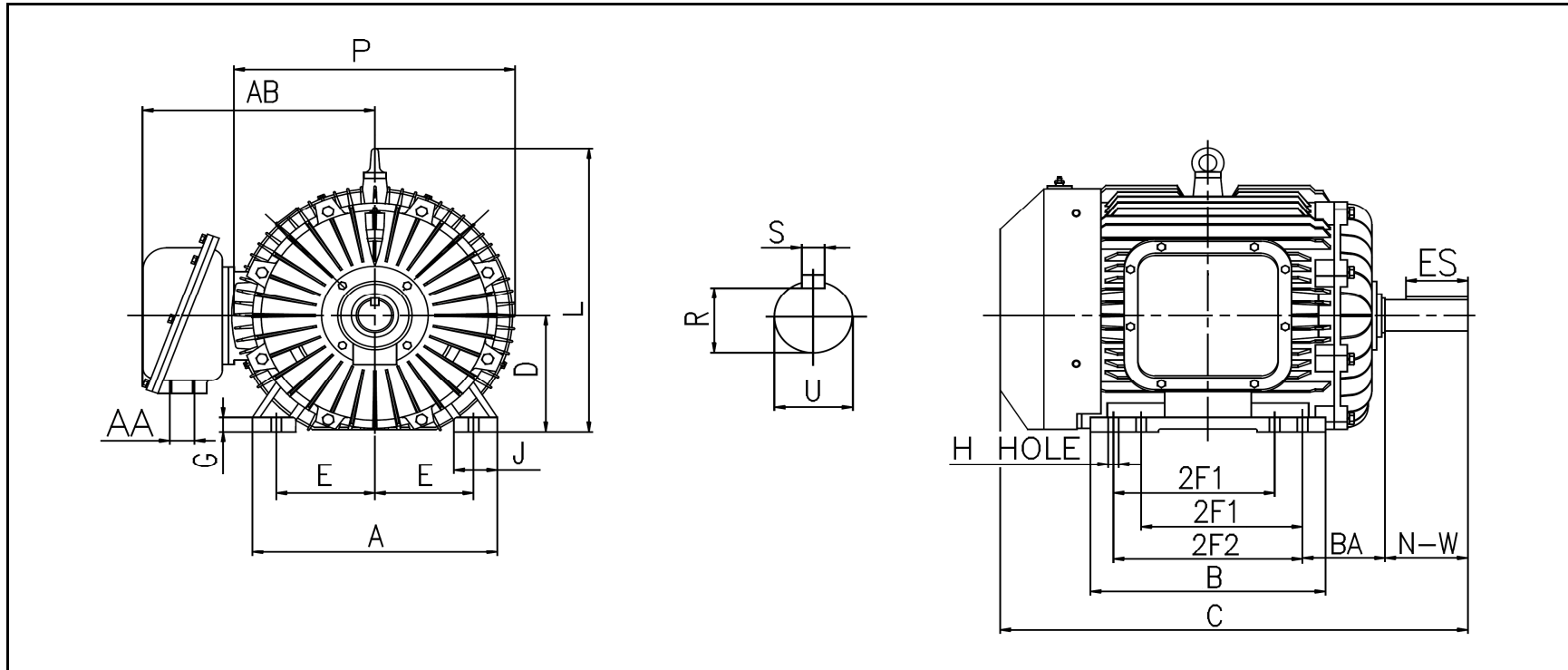

MOUNTING					A	B	C	D	G	J
E	2F1	2F2	H	BA	10.4	9.3	21.85	5.25	0.83	2.4
4.25	5.5	7	0.41	3.5						

L	P	AA	AB	KEY	KEYSEAT	SHAFT	N-W	U
13	12.2	1	11.4	ES	S	R	3.38	1.375
				2.44	0.312	1.201		

ALL DIMENSIONS IN INCHES

REVISED - 09/16/16