



WORLDWIDE ELECTRIC MOTOR DATA SHEET

PEWWE25-18-284JM



HORSEPOWER	25		
RPM / POLES	1800 / 4		
VOLTAGE / PHASE	230 / 460 V / 3		
FRAME	284JM		
ENCLOSURE / DEGREE OF PROTECTION	TEFC / IP54		
FREQUENCY	60 HZ Suitable For 50 HZ Operation With 1.0 SF		
FULL LOAD SPEED	1770 RPM		
SERVICE FACTOR	1.15		
INSULATION CLASS	F		
FULL LOAD AMPS; 230 / 460	58.2 / 29.1 A (Usable On 208V At 64.4 A)		
LOCKED ROTOR AMPS (STARTING); 230 / 460	365 / 182.5 A		
NO LOAD CURRENT	21.2 / 10.6 A		
NEMA CODE LETTER	G		
EFFICIENCY / POWER FACTOR	<u>LOAD</u>	<u>EFF.</u>	<u>P.F.</u>
	100%	93.6%	0.86
	75%	93.9%	0.82
	50%	93.6%	0.73
DUTY CYCLE	CONTINUOUS		
TORQUE	<u>FULL LOAD</u>	<u>LRT</u>	<u>BDT</u>
	74.2 lb.ft.	150%	240%
SLIP	1.67%		
NEMA DESIGN	B		
MOMENT OF INERTIA	3.36 lb.ft. ²		
MAX. TIME LOCKED ROTOR (Hot)	16 Seconds		
SOUND PRESSURE LEVEL	70 dB(A)		
MAX. AMBIENT TEMPERATURE	40° C		
MAX. ELEVATION	3300 Ft. Above Sea Level		
TEMPERATURE RISE (At Full Load)	80° C		
DE BEARING	6311 C3		
ODE BEARING	6309 C3		
REGREASING INT. - DE BEARING	4,000 Hours		
REGREASING INT. - ODE BEARING	5,000 Hours		
GREASE TYPE	Mobil Polyrex EM		
MOUNTING	F1		
ROTATION	Bi-Directional		
SHAFT MATERIAL	1045 Carbon Steel		
CONNECTION DIAGRAM	230 / 460 V - 12 Lead Δ		
APPROXIMATE WEIGHT	385 lbs.		



CC006A





WORLDWIDE ELECTRIC MOTOR DRAWING

PEWWE-284JM

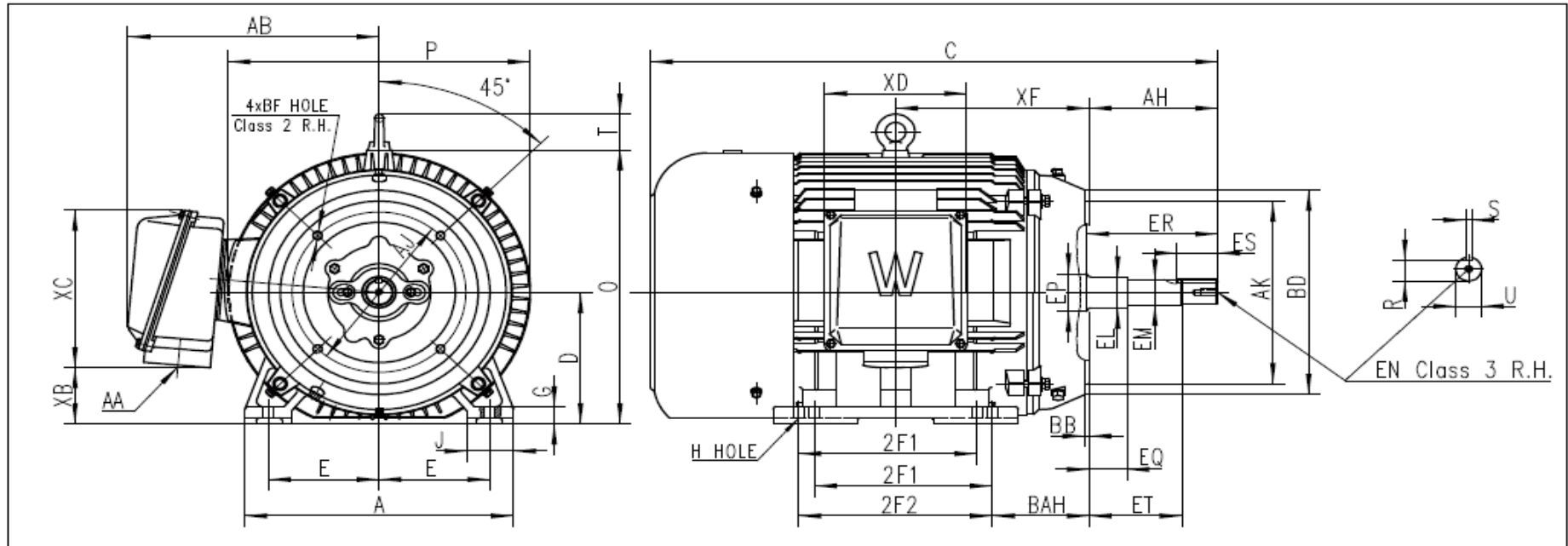

DIMENSIONS - INCHES

MOUNTING					A	B	C	D	G	J	P	O	T	AH	AB	KEY			KEYSET
E	2F1	2F2	H	BAH												S	ES	R	
5.5	---	9.5	0.53	5	14	12.4	27.5	7	0.87	2.8	14	14.3	2.05	5.25	11.5	0.25	2.6	1.11	

FLANGE					SHAFT EXTENSION								AA	XB	XC	XD	XF
AK	AJ	BF	BB	BD	EQ	ET	EM	EL	EP	ER	EN	U					
12.5	11	5/8-11	0.275	13.2	0.625	3	1.375	1.75	2.165	5.5	1/2-13	1.249	1-1/2	3.6	7.4	6.3	9.75