



WORLDWIDE ELECTRIC MOTOR DATA SHEET

PEWWE20-18-256JM



HORSEPOWER	20		
RPM / POLES	1800 / 4		
VOLTAGE / PHASE	230 / 460 V / 3		
FRAME	256JM		
ENCLOSURE / DEGREE OF PROTECTION	TEFC / IP54		
FREQUENCY	60 HZ Suitable For 50 HZ Operation With 1.0 SF		
FULL LOAD SPEED	1765 RPM		
SERVICE FACTOR	1.15		
INSULATION CLASS	F		
FULL LOAD AMPS; 230 / 460	47.4 / 23.7 A (Usable On 208V At 53.0 A)		
LOCKED ROTOR AMPS (STARTING); 230 / 460	290 / 145 A		
NO LOAD CURRENT	18.0 / 9.0 A		
NEMA CODE LETTER	G		
EFFICIENCY / POWER FACTOR	<u>LOAD</u>	<u>EFF.</u>	<u>P.F.</u>
	100%	93.0%	0.85
	75%	93.2%	0.80
	50%	92.9%	0.70
DUTY CYCLE	CONTINUOUS		
TORQUE	<u>FULL LOAD</u>	<u>LRT</u>	<u>BDT</u>
	59.5 lb.ft.	180%	250%
SLIP	1.94%		
NEMA DESIGN	B		
MOMENT OF INERTIA	2.33 lb.ft. ²		
MAX. TIME LOCKED ROTOR (Hot)	12 Seconds		
SOUND PRESSURE LEVEL	68 dB(A)		
MAX. AMBIENT TEMPERATURE	40° C		
MAX. ELEVATION	3300 Ft. Above Sea Level		
TEMPERATURE RISE (At Full Load)	80° C		
DE BEARING	6309 C3		
ODE BEARING	6209 C3		
REGREASING INT. - DE BEARING	5,000 Hours		
REGREASING INT. - ODE BEARING	5,000 Hours		
GREASE TYPE	Mobil Polyrex EM		
MOUNTING	F1		
ROTATION	Bi-Directional		
SHAFT MATERIAL	1045 Carbon Steel		
CONNECTION DIAGRAM	230 / 460 V - 9 Lead Δ		
APPROXIMATE WEIGHT	304 lbs.		



WORLDWIDE ELECTRIC MOTOR DRAWING

PEWWE-256JM

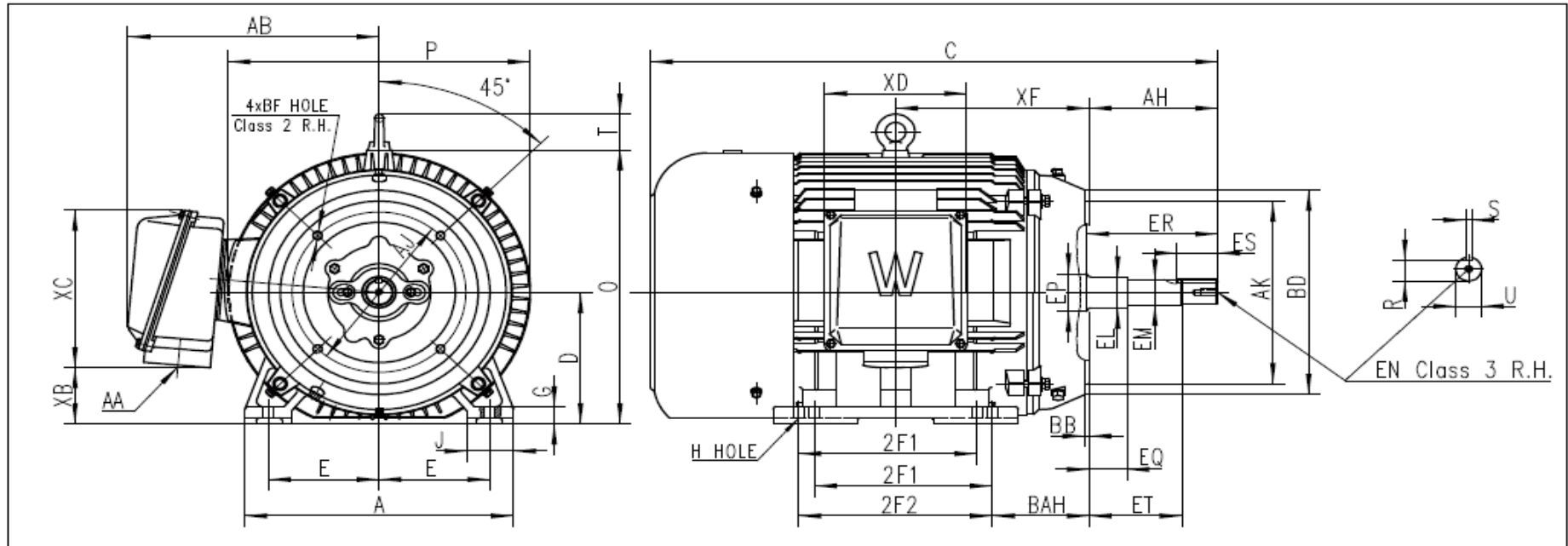

DIMENSIONS - INCHES

MOUNTING					A	B	C	D	G	J	P	O	T	AH	AB	KEY			KEYSET
E	2F1	2F2	H	BAH												S	ES	R	
5	8.25	10	0.53	4.5	12.5	12	27	6.25	0.79	2.4	12.6	12.9	2.05	5.25	10.5	0.25	2.6	1.11	

FLANGE					SHAFT EXTENSION								AA	XB	XC	XD	XF
AK	AJ	BF	BB	BD	EQ	ET	EM	EL	EP	ER	EN	U					
8.5	7.25	1/2-13	0.275	10	0.625	3	1.375	1.75	1.772	5.4	1/2-13	1.249	1-1/2	3	7.4	6.3	9.5