



# WORLDWIDE ELECTRIC MOTOR DATA SHEET

## PEWWE15-36-215JM



HORSEPOWER	15		
RPM / POLES	3600 / 2		
VOLTAGE / PHASE	230 / 460 V / 3		
FRAME	215JM		
ENCLOSURE / DEGREE OF PROTECTION	TEFC / IP54		
FREQUENCY	60 HZ Suitable For 50 HZ Operation With 1.0 SF		
FULL LOAD SPEED	3505 RPM		
SERVICE FACTOR	1.15		
INSULATION CLASS	F		
FULL LOAD AMPS; 230 / 460	34.7 / 17.3 A (Usable On 208V At 38.4 A)		
LOCKED ROTOR AMPS (STARTING); 230 / 460	232 / 116 A		
NO LOAD CURRENT	10.6 / 5.3 A		
NEMA CODE LETTER	G		
EFFICIENCY / POWER FACTOR	<u>LOAD</u>	<u>EFF.</u>	<u>P.F.</u>
	100%	91.0%	0.89
	75%	91.8%	0.86
	50%	91.7%	0.78
DUTY CYCLE	CONTINUOUS		
TORQUE	<u>FULL LOAD</u>	<u>LRT</u>	<u>BDT</u>
	22.5 lb.ft.	160%	240%
SLIP	2.64%		
NEMA DESIGN	B		
MOMENT OF INERTIA	0.369 lb.ft. <sup>2</sup>		
MAX. TIME LOCKED ROTOR (Hot)	8 Seconds		
SOUND PRESSURE LEVEL	69 dB(A)		
MAX. AMBIENT TEMPERATURE	40° C		
MAX. ELEVATION	3300 Ft. Above Sea Level		
TEMPERATURE RISE (At Full Load)	80° C		
DE BEARING	6309ZZ C3		
ODE BEARING	6207ZZ C3		
REGREASING INT. - DE BEARING	---		
REGREASING INT. - ODE BEARING	---		
GREASE TYPE	Mobil Polyrex EM		
MOUNTING	F1		
ROTATION	Bi-Directional		
SHAFT MATERIAL	1045 Carbon Steel		
CONNECTION DIAGRAM	230 / 460 V - 9 Lead Δ		
APPROXIMATE WEIGHT	190 lbs.		



**CC006A**





# WORLDWIDE ELECTRIC MOTOR DRAWING

## PEWWE-215JM

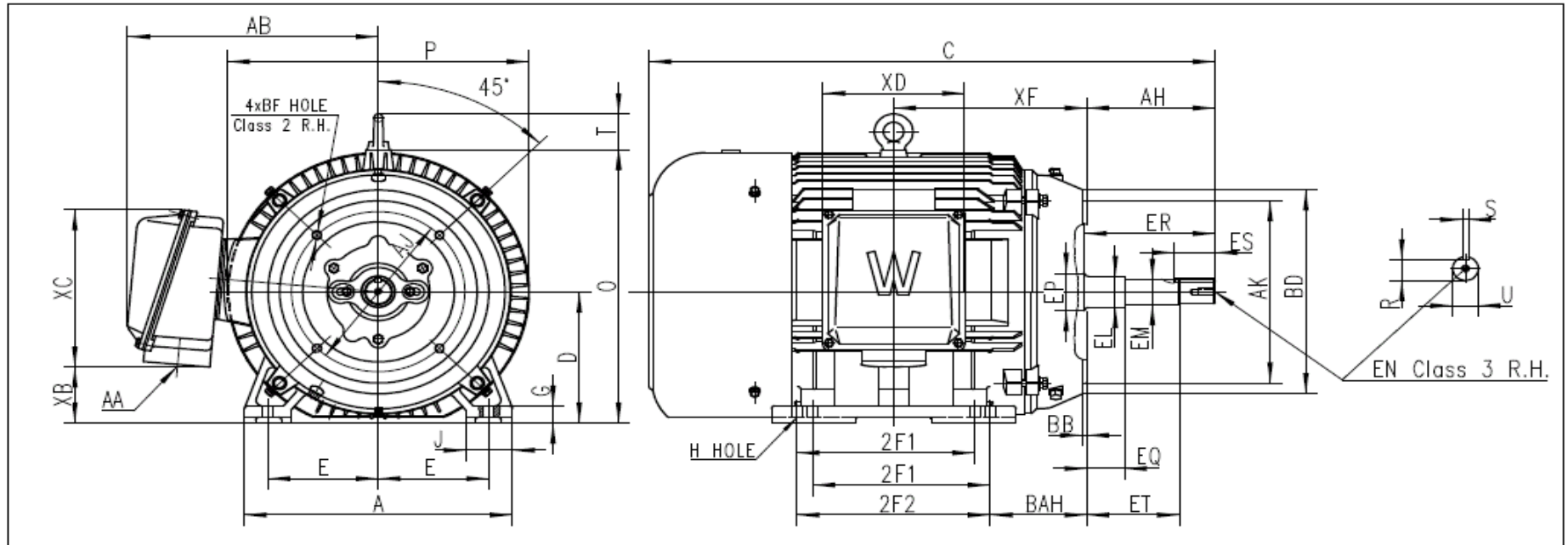

### DIMENSIONS - INCHES

MOUNTING					A	B	C	D	G	J	P	O	T	AH	AB	KEY			KEYSET
E	2F1	2F2	H	BAH												S	ES	R	
4.25	5.5	7	0.41	4.5	10.5	10.5	23	5.25	0.71	2.4	10.4	10.6	1.73	4.25	8.5	0.188	1.732	0.77	

FLANGE					SHAFT EXTENSION								AA	XB	XC	XD	XF
AK	AJ	BF	BB	BD	EQ	ET	EM	EL	EP	ER	EN	U					
8.5	7.25	1/2-13	0.275	8.9	0.625	2.875	1	1.25	1.772	4.5	3/8-16	0.874	1	3.3	5.1	4.6	8.75