



WORLDWIDE ELECTRIC MOTOR DATA SHEET



PEWWE3-18-182JP

HORSEPOWER	3		
RPM / POLES	1800 / 4		
VOLTAGE / PHASE	230 / 460 V / 3		
FRAME	182JP		
ENCLOSURE / DEGREE OF PROTECTION	TEFC / IP54		
FREQUENCY	60 HZ Suitable For 50 HZ Operation With 1.0 SF		
FULL LOAD SPEED	1755 RPM		
SERVICE FACTOR	1.15		
INSULATION CLASS	F		
FULL LOAD AMPS; 230 / 460	8.05 / 4.02 A (Usable On 208V At 8.9 A)		
LOCKED ROTOR AMPS (STARTING); 230 / 460	64.0 / 32.0 A		
NO LOAD CURRENT	4.6 / 2.3 A		
NEMA CODE LETTER	K		
EFFICIENCY / POWER FACTOR	<u>LOAD</u>	<u>EFF.</u>	<u>P.F.</u>
	100%	89.5%	0.78
	75%	89.7%	0.70
	50%	88.5%	0.57
DUTY CYCLE	CONTINUOUS		
TORQUE	<u>FULL LOAD</u>	<u>LRT</u>	<u>BDT</u>
	9.0 lb.ft.	220%	320%
SLIP	2.50%		
NEMA DESIGN	B		
MOMENT OF INERTIA	0.23 lb.ft. ²		
MAX. TIME LOCKED ROTOR (Hot)	12 Seconds		
SOUND PRESSURE LEVEL	63 dB(A)		
MAX. AMBIENT TEMPERATURE	40° C		
MAX. ELEVATION	3300 Ft. Above Sea Level		
TEMPERATURE RISE (At Full Load)	80° C		
DE BEARING	6307ZZ C3		
ODE BEARING	6206ZZ C3		
REGREASING INT. - DE BEARING	---		
REGREASING INT. - ODE BEARING	---		
GREASE TYPE	Mobil Polyrex EM		
MOUNTING	F1		
ROTATION	Bi-Directional		
SHAFT MATERIAL	1045 Carbon Steel		
CONNECTION DIAGRAM	230 / 460 V - 9 Lead Y		
APPROXIMATE WEIGHT	86 lbs.		



CC006A





WORLDWIDE ELECTRIC MOTOR DRAWING

PEWWE-182JP

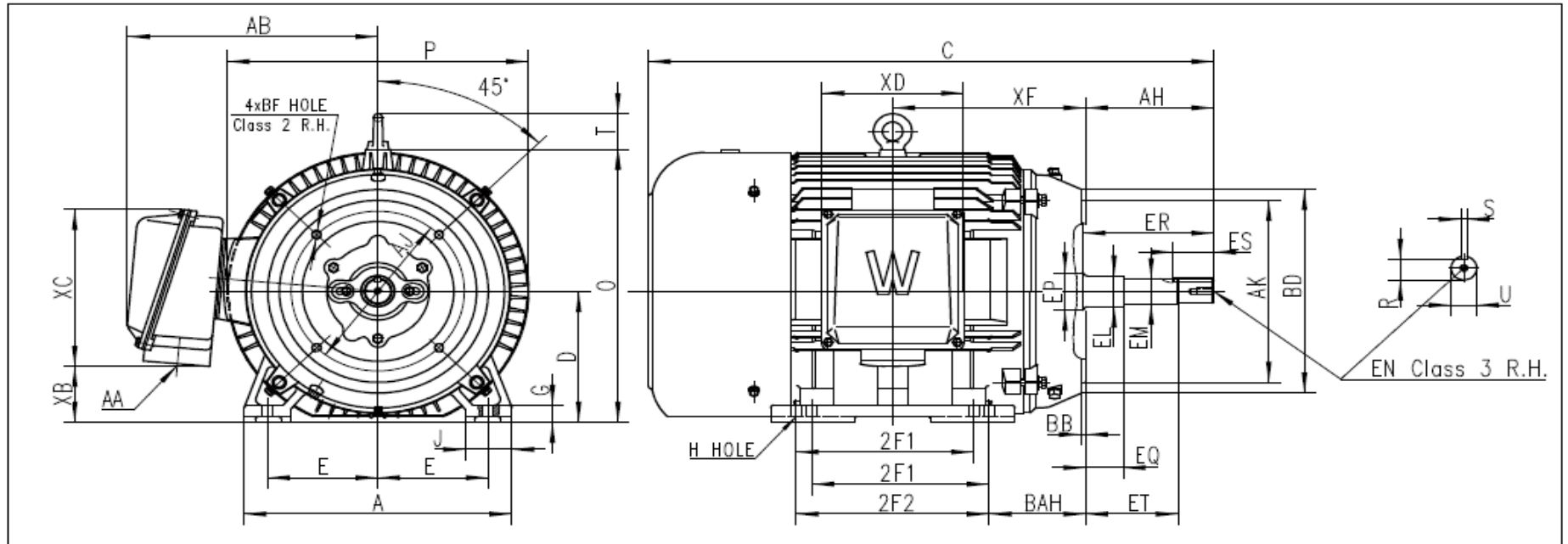

DIMENSIONS - INCHES

MOUNTING					A	B	C	D	G	J	P	O	T	AH	AB	KEY			KEYSET
E	2F1	2F2	H	BAH												S	ES	R	
3.75	---	4.5	0.41	3.37	9	7.2	20	4.5	0.6	2	9.7	9.5	1.42	7.31	8	0.188	1.65	0.768	

FLANGE					SHAFT EXTENSION								AA	XB	XC	XD	XF
AK	AJ	BF	BB	BD	EQ	ET	EM	EL	EP	ER	EN	U					
4.5	5.875	3/8-16	0.156	6.6	1.563	5.937	1	1.25	1.378	7.34	3/8-16	0.874	1	2.2	5.1	4.6	5.63