



WORLDWIDE ELECTRIC MOTOR DATA SHEET

PEWWE500-18-586/7BB



HORSEPOWER	500		
RPM / POLES	1800 / 4		
VOLTAGE / PHASE	460 V / 3		
FRAME	586/7T		
ENCLOSURE / DEGREE OF PROTECTION	TEFC / IP55		
FREQUENCY	60 HZ		
FULL LOAD SPEED	1790 RPM		
SERVICE FACTOR	1.0		
INSULATION CLASS	F		
FULL LOAD AMPS	535 A		
LOCKED ROTOR AMPS (STARTING)	3625 A		
NO LOAD CURRENT	130 A		
NEMA CODE LETTER	G		
EFFICIENCY / POWER FACTOR	<u>LOAD</u>	<u>EFF.</u>	<u>P.F.</u>
	100%	96.2%	0.91
	75%	96.2%	0.89
	50%	96.0%	0.85
DUTY CYCLE	CONTINUOUS		
TORQUE	<u>FULL LOAD</u>	<u>LRT</u>	<u>BDT</u>
	1466 lb.ft.	200%	250%
SLIP	0.560%		
NEMA DESIGN	B		
MOMENT OF INERTIA	205.000 lb.ft. ²		
SOUND PRESSURE LEVEL	92 dB(A)		
MAX. TIME LOCKED ROTOR (Hot)	16 Seconds		
MAX. AMBIENT TEMPERATURE	40° C		
MAX. ELEVATION	3300 Ft. Above Sea Level		
TEMPERATURE RISE (At Full Load)	80° C		
DE BEARING	6326 C3		
ODE BEARING	6324 C3		
REGREASING INT. - DE BEARING	1,000 Hours		
REGREASING INT. - ODE BEARING	1,500 Hours		
GREASE TYPE	Mobil Polyrex EM		
MOUNTING	F1		
ROTATION	Bi-Directional		
CONNECTION DIAGRAM	460 V - 6 Lead Δ		
SHAFT MATERIAL	4140 Carbon Steel		
APPROX. WEIGHT	4630 lbs.		
INVERTER RATING	3:1 CT / 6:1 VT PWM Type		



CC006A





WORLDWIDE ELECTRIC MOTOR DRAWING

PEWWE-586/7-4P

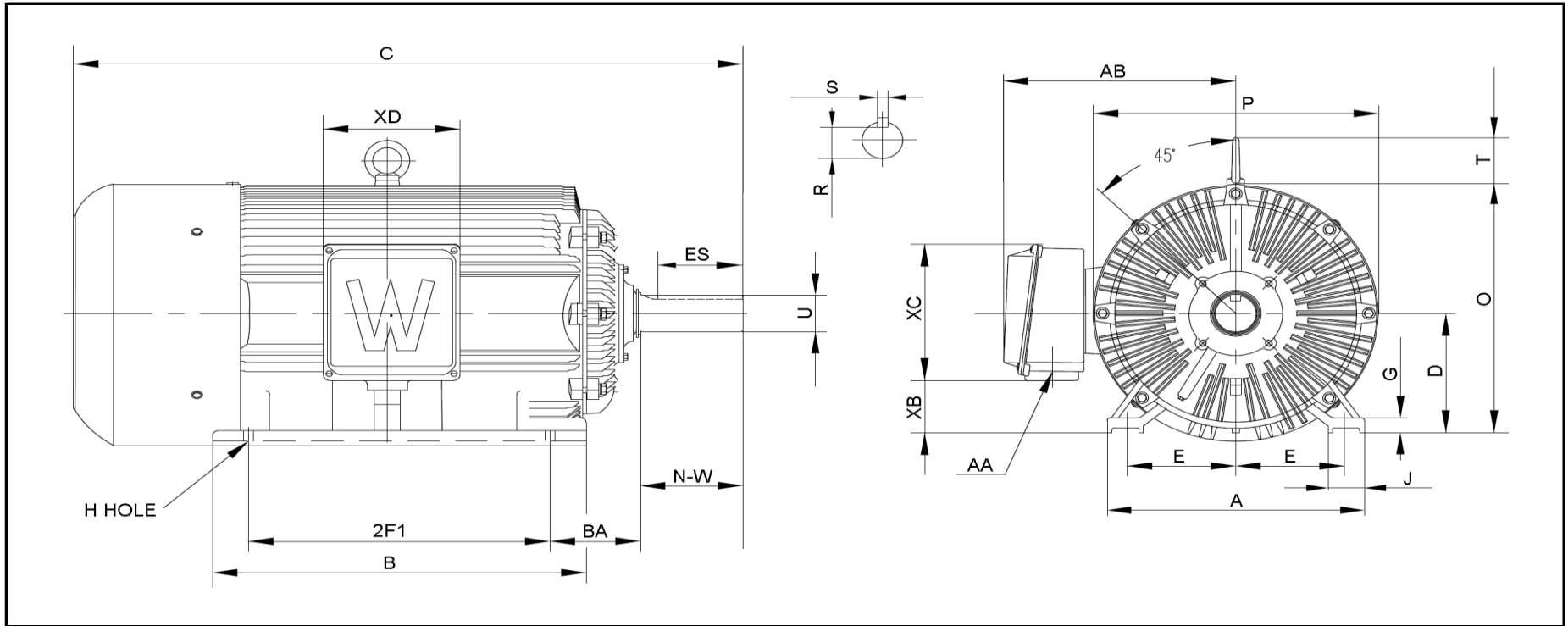

DIMENSIONS - INCHES

MOUNTING					A	B	C	D	G	J	P	O	T	AB
E	2F1	2F2	H	BA										
11.5	22	25	1.125	10	28	33.85	67	14.5	2.05	5	30.5	28.9	5	25

KEY		KEYSET	SHAFT		TERMINAL BOX				
S	ES	R	N-W	U	AA	XB	XC	XD	XE
1	10	3.309	11.625	3.875	2 x 3"	5	16.5	14.5	---