



**WORLDWIDE ELECTRIC MOTOR DATA SHEET**



**PEWWE350-12-449T**

HORSEPOWER	<b>350</b>		
RPM / POLES	<b>1200 / 6</b>		
VOLTAGE / PHASE	<b>460 V / 3</b>		
FRAME	<b>449T</b>		
ENCLOSURE / DEGREE OF PROTECTION	<b>TEFC / IP55</b>		
FREQUENCY	<b>60 HZ</b>		
FULL LOAD SPEED	<b>1190 RPM</b>		
SERVICE FACTOR	<b>1.15</b>		
INSULATION CLASS	<b>F</b>		
FULL LOAD AMPS	<b>407 A</b>		
LOCKED ROTOR AMPS (STARTING)	<b>2550 A</b>		
NO LOAD CURRENT	<b>135 A</b>		
NEMA CODE LETTER	<b>G</b>		
EFFICIENCY / POWER FACTOR	<u>LOAD</u>	<u>EFF.</u>	<u>P.F.</u>
	<b>100%</b>	<b>95.8%</b>	<b>0.84</b>
	<b>75%</b>	<b>95.8%</b>	<b>0.80</b>
	<b>50%</b>	<b>95.5%</b>	<b>0.72</b>
DUTY CYCLE	<b>CONTINUOUS</b>		
TORQUE	<u>FULL LOAD</u>	<u>LRT</u>	<u>BDT</u>
	<b>1544 lb.ft.</b>	<b>190%</b>	<b>270%</b>
SLIP	<b>0.83%</b>		
NEMA DESIGN	<b>B</b>		
MOMENT OF INERTIA	<b>131 lb.ft.<sup>2</sup></b>		
SOUND PRESSURE LEVEL	<b>83 dB(A)</b>		
MAX. TIME LOCKED ROTOR (Hot)	<b>8 Seconds</b>		
MAX. AMBIENT TEMPERATURE	<b>40° C</b>		
MAX. ELEVATION	<b>3300 Ft. Above Sea Level</b>		
TEMPERATURE RISE (At Full Load)	<b>80° C</b>		
DE BEARING	<b>NU322 C3</b>		
ODE BEARING	<b>6320 C3</b>		
REGREASING INT. - DE BEARING	<b>2,000 Hours</b>		
REGREASING INT. - ODE BEARING	<b>2,700 Hours</b>		
GREASE TYPE	<b>Mobil Polyrex EM</b>		
MOUNTING	<b>F1</b>		
ROTATION	<b>Bi-Directional</b>		
CONNECTION DIAGRAM	<b>460 V - 6 Lead Δ</b>		
SHAFT MATERIAL	<b>4140 Carbon Steel</b>		
APPROX. WEIGHT	<b>2930 lbs.</b>		
INVERTER RATING	<b>3:1 CT / 6:1 VT PWM Type</b>		



**CC006A**





# WORLDWIDE ELECTRIC MOTOR DRAWING

## PEWWE-449T

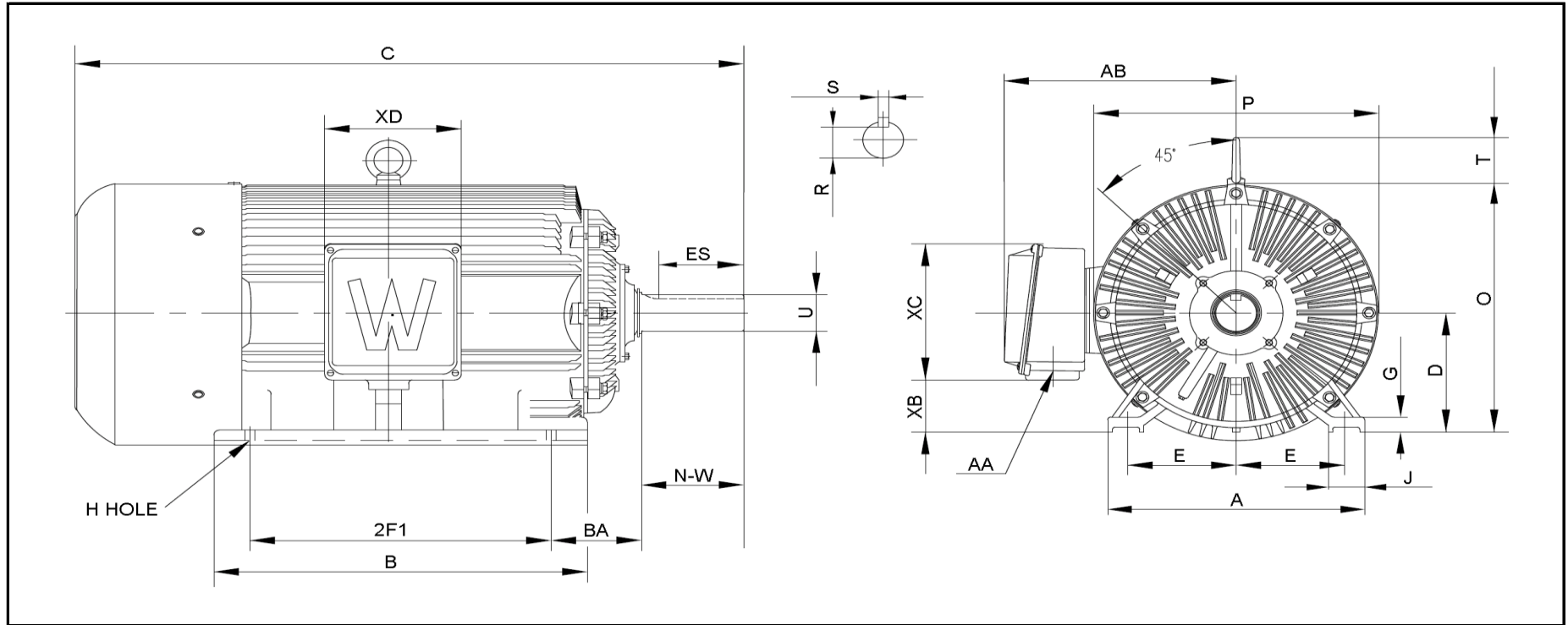

**DIMENSIONS - INCHES**

MOUNTING					A	B	C	D	G	J	P	O	T	AB
E	2F1	2F2	H	BA										
9	25	---	0.81	7.5	22	31	58	11	1.575	3.35	24	23	4.25	19.5

KEY		KEYSET	SHAFT		TERMINAL BOX				
S	ES	R	N-W	U	AA	XB	XC	XD	XE
0.875	7.01	2.88	8.5	3.375	2 x 3"	4.7	12	11.5	---