



WORLDWIDE ELECTRIC MOTOR DATA SHEET

PEWWE300-18-449TBB



HORSEPOWER	300		
RPM / POLES	1800 / 4		
VOLTAGE / PHASE	460 V / 3		
FRAME	449T		
ENCLOSURE / DEGREE OF PROTECTION	TEFC / IP55		
FREQUENCY	60 HZ		
FULL LOAD SPEED	1790 RPM		
SERVICE FACTOR	1.15		
INSULATION CLASS	F		
FULL LOAD AMPS	336 A		
LOCKED ROTOR AMPS (STARTING)	2200 A		
NO LOAD CURRENT	103 A		
NEMA CODE LETTER	G		
EFFICIENCY / POWER FACTOR	<u>LOAD</u>	<u>EFF.</u>	<u>P.F.</u>
	100%	96.2%	0.87
	75%	96.3%	0.85
	50%	96.1%	0.78
DUTY CYCLE	CONTINUOUS		
TORQUE	<u>FULL LOAD</u>	<u>LRT</u>	<u>BDT</u>
	880 lb.ft.	200%	250%
SLIP	0.56%		
NEMA DESIGN	B		
MOMENT OF INERTIA	94.10 lb.ft.²		
SOUND PRESSURE LEVEL	93 dB(A)		
MAX. TIME LOCKED ROTOR (Hot)	12 Seconds		
MAX. AMBIENT TEMPERATURE	40° C		
MAX. ELEVATION	3300 Ft. Above Sea Level		
TEMPERATURE RISE (At Full Load)	80° C		
DE BEARING	6320 C3		
ODE BEARING	6320 C3		
REGREASING INT. - DE BEARING	1,300 Hours		
REGREASING INT. - ODE BEARING	1,800 Hours		
GREASE TYPE	Mobil Polyrex EM		
MOUNTING	F1		
ROTATION	Bi-Directional		
CONNECTION DIAGRAM	460 V - 6 Lead Δ		
SHAFT MATERIAL	4140 Carbon Steel		
APPROX. WEIGHT	2728 lbs.		
INVERTER RATING	3:1 CT / 6:1 VT PWM Type		



CC006A





WORLDWIDE ELECTRIC MOTOR DRAWING

PEWWE-449T

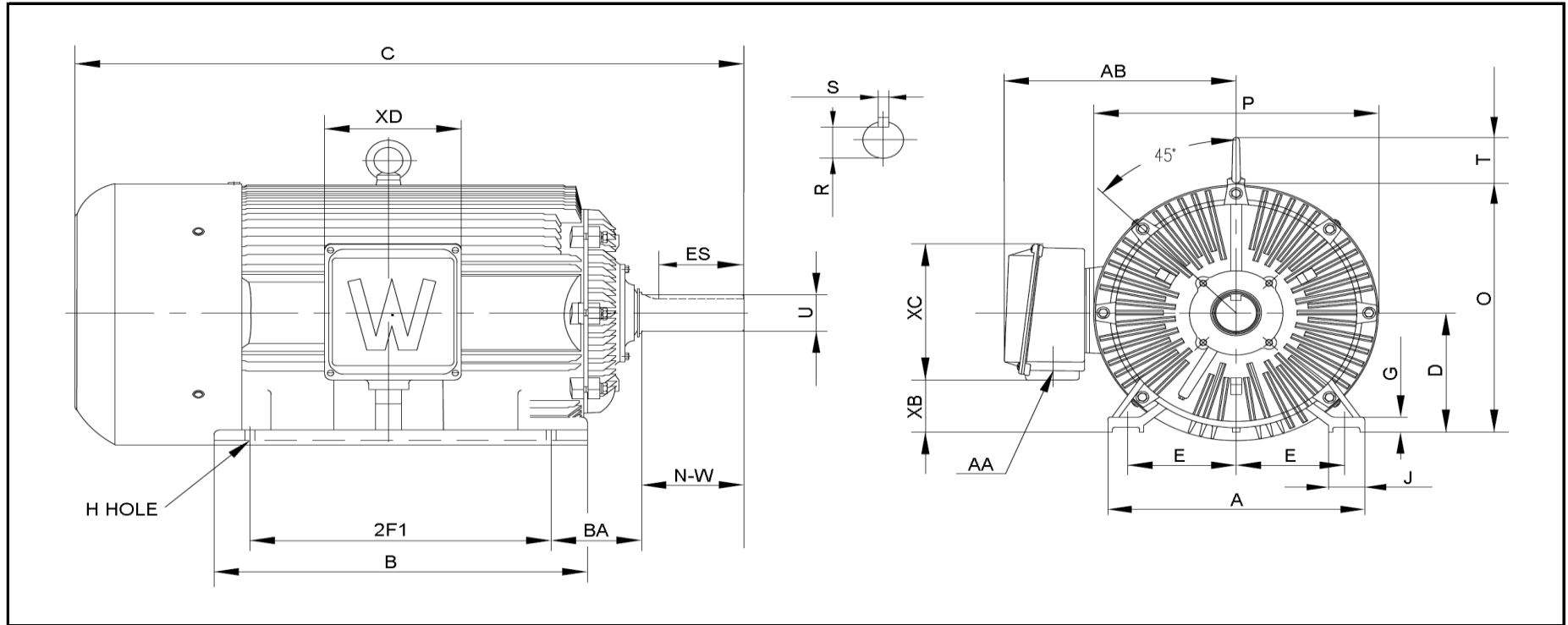

DIMENSIONS - INCHES

MOUNTING					A	B	C	D	G	J	P	O	T	AB
E	2F1	2F2	H	BA										
9	25	---	0.81	7.5	22	31	58	11	1.575	3.35	24	23	4.25	19.5

KEY		KEYSET	SHAFT		TERMINAL BOX				
S	ES	R	N-W	U	AA	XB	XC	XD	XE
0.875	7.01	2.88	8.5	3.375	2 x 3"	4.7	12	11.5	---