



WORLDWIDE ELECTRIC MOTOR DATA SHEET



EPCR300-18-449T

HORSEPOWER	300		
RPM / POLES	1800 / 4		
VOLTAGE / PHASE	460 V / 3		
FRAME	449T		
ENCLOSURE / DEGREE OF PROTECTION	TEFC / IP55		
FREQUENCY	60 HZ Suitable For 50 HZ Operation With 1.0 SF		
FULL LOAD SPEED	1790 RPM		
SERVICE FACTOR	1.25 SF at 40° C / 1.0 SF at 55° C		
INSULATION CLASS	F		
FULL LOAD AMPS; 230 / 460	340 A		
LOCKED ROTOR AMPS (STARTING); 230 / 460	2200 A		
NO LOAD CURRENT	112 A		
NEMA CODE LETTER	G		
EFFICIENCY / POWER FACTOR	<u>LOAD</u>	<u>EFF.</u>	<u>P.F.</u>
	100%	96.2%	0.86
	75%	95.2%	0.85
	50%	94.0%	0.79
DUTY CYCLE	S1 / Continuous		
TORQUE	<u>FULL LOAD</u>	<u>LRT</u>	<u>BDT</u>
	881 lb.ft.	230%	330%
SLIP	0.57%		
NEMA DESIGN	B		
MOMENT OF INERTIA	114 lb.ft. ²		
NUMBER OF STARTS (Hot / Cold)	2 Hot / 3 Cold		
MAX. AMBIENT TEMPERATURE	40° C at 1.25 SF / 55° C at 1.0 SF		
MAX. ELEVATION	3300 Ft. Above Sea Level		
TEMPERATURE RISE (At Full Load)	80° C		
DE BEARING	NU322		
ODE BEARING	6320		
GREASE TYPE	Mobil Polyrex EM		
MOUNTING	F1		
ROTATION	Bi-Directional		
APPROXIMATE WEIGHT	2698 lbs.		
AREA CLASSIFICATION	Class I, Division 2, Groups A, B, C, D		
TEMPERATURE CODE AT 40°C AMBIENT	T3A		
TEMPERATURE CODE AT 55°C AMBIENT	T3		
INVERTER RATING	10:1 CT / 20:1 VT PWM Type		
SPECIFICATION - In Accordance With	NEMA, CSA		



CC067A





WORLDWIDE ELECTRIC MOTOR DRAWING

EPCR-449T

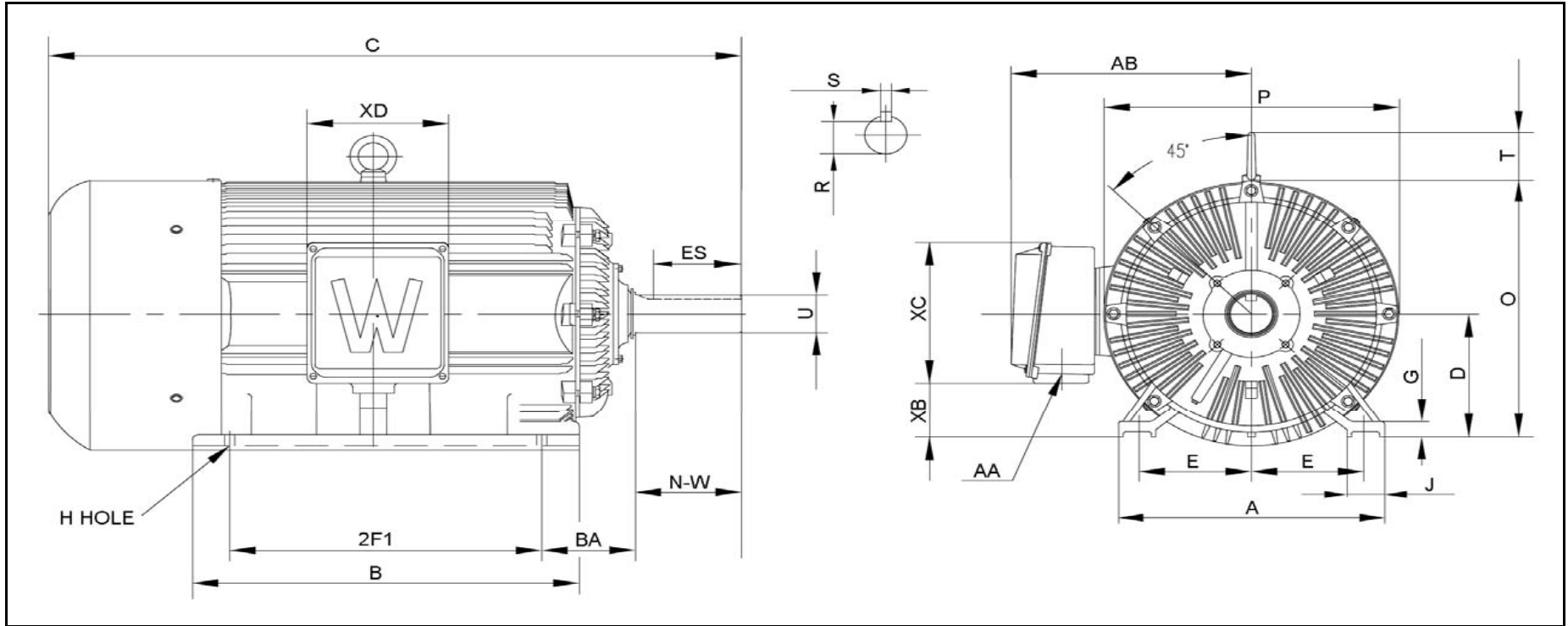

DIMENSIONS - INCHES

MOUNTING					A	B	C	D	G	J	P	O	T	AB
E	2F1	2F2	H	BA										
9	20	25	0.81	7.5	22	31	55.51	11	1.575	3.35	24	23	4.25	19.07

KEY		KEYSET	SHAFT		TERMINAL BOX				
S	ES	R	N-W	U	AA	XB	XC	XD	XE
0.875	7.01	2.88	8.5	3.375	2 x 3"	4.74	---	---	20