

**PESS215TC10M-4-RB**

WASHDOWN DUTY MOTOR

NEMA PREMIUM EFFICIENCY

STAINLESS STEEL CONSTRUCTION - ROUND BODY (C-FLANGE FOOTLESS)

TOTALLY ENCLOSED FAN COOLED - IP66 CONSTRUCTION

INVERTER DUTY 10:1 CT; 20:1 VT - NEMA MG1 PART 31

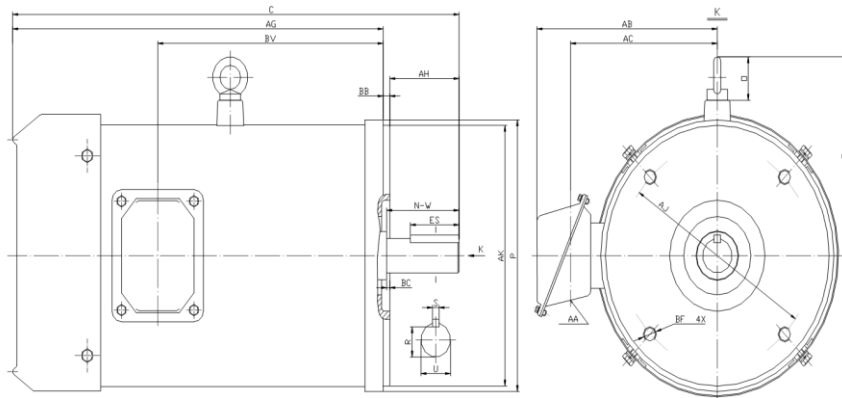

**DIMENSIONS**

HP	RPM	Frame	Mounting									
			C	P	AK	AJ	AH	AG	BA	BB	BC	BF
10	1800	215TC	21.50	10.08	8.500	7.250	3.12	18.13	N/A	0.25	0.25	4*1/2-13

Shaft Extension, Key Set					Conduit Box				Bearings		Mount
U	R	S	ES	N-W	AA	AB	AC	BV	DE	ODE	
1.375	1.201	0.312	2.41	3.38	0.94	7.70	6.20	12.15	6308-2RS	6208-2RS	F1

**BEARING LUBRICATION:** The bearings come lubricated with Mobil Polyrex EM Polyurea Grease.





**PESS215TC10M-4-RB**

**WASHDOWN DUTY MOTOR**  
**NEMA PREMIUM EFFICIENCY**  
**STAINLESS STEEL CONSTRUCTION - ROUND BODY (C-FLANGE FOOTLESS)**  
**TOTALLY ENCLOSED FAN COOLED - IP66 CONSTRUCTION**  
**INVERTER DUTY 10:1 CT; 20:1 VT - NEMA MG1 PART 31**

**PERFORMANCE DATA**

HP	RPM	Frame	Voltage	Frequency (Hz)	Full Load S.F.	Insulation Class	NEMA Design	Slip (%)	NEMA Code	Enclosure Type	IP Rating	Max. Ambient
10	1760	215TC	208-230/460	60	1.15	F	B	2.2	H	TEFC	66	40° C

Amps (460V)		Efficiency (%)				Power Factor			Torque (ft-lb)			DE Bearing	ODE Bearing	Connection	Weight (lbs.)
FLA	LRA	100%	75%	50%	Min.	100%	75%	50%	FLT	LRT %	BDT %				
12.2	81.0	91.7	92.0	91.0	90.2	0.85	0.76	0.65	29.3	250	270	6308-2RS	6208-2RS	9 Lead 2Y/Y	209

**NAME PLATE**

				<b>WASHDOWN DUTY STAINLESS STEEL MOTORS</b>		<b>CONNECTION DIAGRAMS</b>	
<b>INVERTER DUTY 20:1 VT; 10:1 CT</b>						<b>208-230V</b>	
CAT NO:	PESS215TC10M-4-RB	FRAME	215TC	PHASE	3		
HZ	60	S.F.	1.15	HZ	50	S.F.	1.2
ENCL	TEFC	IP	66	DUTY	CONT	DES	B
HP	10	RPM	1760	HP	7.5	RPM	1460
VOLTS	208-230/460	VOLTS	190/380	AMB	40° C	INS	F
FLA	26 - 24.4 / 12.2	FLA	22/11	DE BEARING	6308-2RS		
CODE	H	P.F.	0.85	CODE	H	P.F.	0.87
ODE BEARING	6208-2RS			LUB:	Mobil Polyrex EM		
EFF	91.7	MIN	90.2	EFF	90	MIN	88.5
MOTOR WEIGHT	209	LBS		CONNECTION	9 Lead 2Y/Y		SER NO
Special purpose motor designed for washdown applications and extremely corrosive environments. Hernando, Mississippi							
						<b>460V</b>	
						CC 082A	

**APPLICATIONS:**

Applications include washdown applications, food processing, chemical processing, pharmaceuticals, poultry processing, meat processing, dairy applications, bakeries, snack foods, bottling and extremely corrosive environments.