

PESS182TC3M-2-RB

WASHDOWN DUTY MOTOR

NEMA PREMIUM EFFICIENCY

STAINLESS STEEL CONSTRUCTION - ROUND BODY (C-FLANGE FOOTLESS)

TOTALLY ENCLOSED FAN COOLED - IP66 CONSTRUCTION

INVERTER DUTY 10:1 CT; 20:1 VT - NEMA MG1 PART 31

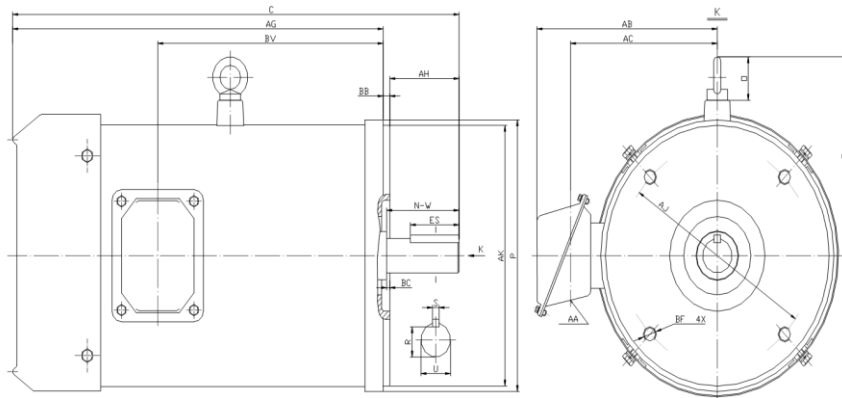

DIMENSIONS

HP	RPM	Frame	Mounting									
			C	P	AK	AJ	AH	AG	BA	BB	BC	BF
3	3600	182TC	17.00	8.85	8.500	7.250	2.62	14.13	N/A	0.25	0.12	4*1/2-13

Shaft Extension, Key Set					Conduit Box				Bearings		Mount
U	R	S	ES	N-W	AA	AB	AC	BV	DE	ODE	
1.125	0.986	0.250	1.78	2.75	0.94	7.00	5.30	8.60	6308-2RS	6306-2RS	F1

BEARING LUBRICATION: The bearings come lubricated with Mobil Polyrex EM Polyurea Grease.





PESS182TC3M-2-RB

WASHDOWN DUTY MOTOR

NEMA PREMIUM EFFICIENCY

STAINLESS STEEL CONSTRUCTION - ROUND BODY (C-FLANGE FOOTLESS)

TOTALLY ENCLOSED FAN COOLED - IP66 CONSTRUCTION

INVERTER DUTY 10:1 CT; 20:1 VT - NEMA MG1 PART 31

PERFORMANCE DATA

HP	RPM	Frame	Voltage	Frequency (Hz)	Full Load S.F.	Insulation Class	NEMA Design	Slip (%)	NEMA Code	Enclosure Type	IP Rating	Max. Ambient
3	3510	182TC	208-230/460	60	1.15	F	B	2.5	K	TEFC	66	40° C

Amps (460V)		Efficiency (%)				Power Factor			Torque (ft-lb)			DE Bearing	ODE Bearing	Connection	Weight (lbs.)
FLA	LRA	100%	75%	50%	Min.	100%	75%	50%	FLT	LRT %	BDT %				
4.1	32.0	86.5	87.0	86.0	84.0	0.89	0.75	0.63	4.4	270	290	6308-2RS	6306-2RS	9 Lead 2Y/Y	76

NAME PLATE

				WASHDOWN DUTY STAINLESS STEEL MOTORS		CONNECTION DIAGRAMS	
INVERTER DUTY 20:1 VT; 10:1 CT						208-230V	
CAT NO:	PESS182TC3M-2-RB	FRAME	182TC	PHASE	3		
HZ	60	S.F.	1.15	HZ	50	S.F.	1.2
ENCL	TEFC	IP	66	DUTY	CONT	DES	B
HP	3	RPM	3510	HP	2	RPM	2930
VOLTS	208-230/460	VOLTS	190/380	AMB	40° C	INS	F
FLA	8.8 - 8.1 / 4.05	FLA	6.6/3.3	DE BEARING	6308-2RS		
CODE	K	P.F.	0.89	CODE	K	P.F.	0.91
ODE BEARING	6306-2RS			LUB:	Mobil Polyrex EM		
EFF	86.5	MIN	84.0	EFF	84	MIN	81.5
MOTOR WEIGHT	76	LBS		CONNECTION	9 Lead 2Y/Y		SER NO
Special purpose motor designed for washdown applications and extremely corrosive environments. Hernando, Mississippi							
						460V	
						CC 082A	

APPLICATIONS:

Applications include washdown applications, food processing, chemical processing, pharmaceuticals, poultry processing, meat processing, dairy applications, bakeries, snack foods, bottling and extremely corrosive environments.