

V1-100D4-W40416A

VERTICAL HOLLOW SHAFT MOTOR
 NEMA PREMIUM EFFICIENCY
 HIGH THRUST DESIGN
 THREE PHASE, OPEN DRIP PROOF (WP1) ENCLOSURE
 NON-REVERSE BALL TYPE RATCHET
 COUPLING INCLUDED

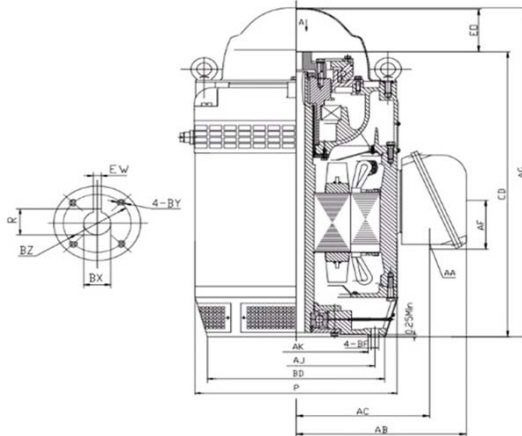

DIMENSIONS

HP	RPM	Frame	MOUNTING DIMENSIONS													
			BD	AJ	AK	BF	BX	BZ	EW	R	BY	CD	E0 >	AC	AA	AF
100	1770	404TP	16.50	14.750	13.50	0.69	1.50	2.13	0.38	1.706	1/4-20	36.94	6.46	16.18	3" NPT	7.56

OVERALL DIMENSIONS			BEARINGS	
P	AB	AG	UPPER	BOTTOM
23.30	20.70	43.40	7230B	6317

COUPLING: Motor comes with a 1.50 coupling. You may select a different size coupling at no extra charge.

BEARING LUBRICATION: The bottom bearing comes lubricated with Mobil Polyrex EM Polyurea Grease.

OIL RESERVOIR: Motor is shipped without oil. The oil capacity is 4.76 quarts.

STEADY BUSHING: Motor is designed to accept a steady bushing. The bore size is 2.047 inches.





V1-100D4-W40416A

VERTICAL HOLLOW SHAFT MOTOR
NEMA PREMIUM EFFICIENCY
HIGH THRUST DESIGN
THREE PHASE, OPEN DRIP PROOF (WP1) ENCLOSURE
NON-REVERSE BALL TYPE RATCHET

PERFORMANCE DATA

HP	RPM	Frame	Voltage	Frequency (Hz)	Full Load S.F.	Insulation Class	NEMA Design	Slip (%)	NEMA Code	Enclosure Type	IP Rating	Max. Ambient	Rating CONT
100	1788	404TP	230/460	60	1.15	F	B	0.7	H	WP1	23	40° C	S1

Amps (460V)		Efficiency (%)				Power Factor			Torque (ft-lb)			Down Thrust	Angular Contact Bearing	Radial Ball Bearing	Connection	Weight (lbs.)
FLA	LRA	100%	75%	50%	Min.	100%	75%	50%	FLT	LRT %	BDT %	6700	UPPER	BOTTOM	12 Lead 2Δ/Δ	1726
112.0	818.0	95.4	94.0	92.0	94.5	0.88	0.88	0.82	292.0	220	240	6700	7230B	6317		

NAME PLATE

				VERTICAL HOLLOW SHAFT ELECTRIC MOTOR				CONNECTION DIAGRAMS			
INVERTER RATED 10:1 VT				HIGH THRUST DESIGN				208-230V			
MODEL	V1-100D4-W40416A			PHASE	3	Hz	60				
HP	100	FRAME	404TP	VOLTS	230/460						
DESIGN	B	CODE	H	AMPS	224/112						
NOM EFF.	95.4	P.F.	0.88	INSULATION CLASS	F						
RATING CONT	S1	S.F.	1.15	MAX AMB.	40° C	WEIGHT	1726 LBS.				
DOWN THRUST	6700			ENCLOSURE TYPE	WP1						
UPPER BEARING	7230B			BOTTOM BEARING	6317						
OIL CAP. UPPER BEARING	4.76	QTS		LUBRICATION	MOBILE POLYREX EM						
NON-REVERSE RATCHET - BALL TYPE				SERIAL NO.							
Specifically designed for use on deep well turbine pump applications. Hernando, Mississippi								PART WIND START CAPABLE @ 230V			

APPLICATIONS:

Specifically designed for use on deep well turbine pump applications. The coupling is equipped with a non-reverse ratchet, which prevents motor rotation from backspin at shutdown. These motors are built to NEMA standards and have special bearing arrangements to carry heavy thrust loads.