

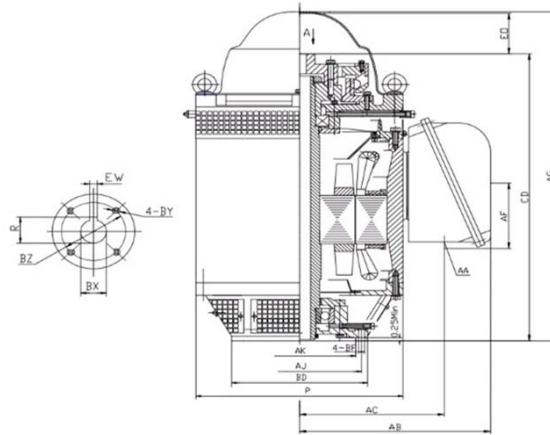

V1-10D4-W21510A

VERTICAL HOLLOW SHAFT MOTOR
 NEMA PREMIUM EFFICIENCY
 HIGH THRUST DESIGN
 THREE PHASE, OPEN DRIP PROOF (WP1) ENCLOSURE
 NON-REVERSE BALL TYPE RATCHET
 COUPLING INCLUDED



DIMENSIONS

HP	RPM	Frame	MOUNTING DIMENSIONS													
			BD	AJ	AK	BF	BX	BZ	EW	R	BY	CD	E0 >	AC	AA	AF
10	1750	215TP	10.00	9.125	8.25	0.44	1.00	1.38	0.25	1.114	10-32	17.56	4.06	10.60	3" NPT	5.83

OVERALL DIMENSIONS			BEARINGS	
P	AB	AG	UPPER	BOTTOM
15.20	14.06	21.62	6210	7310B

COUPLING: Motor comes with a 1.0" coupling. You may select a different size coupling at no extra charge.

BEARING LUBRICATION: The bottom bearing comes lubricated with Mobil Polyrex EM Polyurea Grease.





V1-10D4-W21510A

VERTICAL HOLLOW SHAFT MOTOR
NEMA PREMIUM EFFICIENCY
HIGH THRUST DESIGN
THREE PHASE, OPEN DRIP PROOF (WP1) ENCLOSURE
NON-REVERSE BALL TYPE RATCHET

PERFORMANCE DATA

HP	RPM	Frame	Voltage	Frequency (Hz)	Full Load S.F.	Insulation Class	NEMA Design	Slip (%)	NEMA Code	Enclosure Type	IP Rating	Max. Ambient	Rating CONT
10	1780	215TP	230/460	60	1.15	F	B	1.1	H	WP1	23	40° C	S1

Amps (460V)		Efficiency (%)					Power Factor			Torque (ft-lb)			Down Thrust	Angular Contact Bearing	Radial Ball Bearing	Connection	Weight (lbs.)
FLA	LRA	100%	75%	50%	Min.	100%	75%	50%	FLT	LRT %	BDT %	2500	UPPER	BOTTOM	12 Lead 2Δ/Δ	366	
12.2	85.0	91.7	91.8	90.2	90.2	0.84	0.79	0.70	29.0	220	250		6210	7310B			

NAME PLATE

VERTICAL HOLLOW SHAFT ELECTRIC MOTOR				CONNECTION DIAGRAMS			
INVERTER RATED 10:1 VT				HIGH THRUST DESIGN			
MODEL	V1-10D4-W21510A		PHASE	3	Hz	60	
HP	10	FRAME	215TP	VOLTS	230/460		
DESIGN	B	CODE	H	AMPS	24.4/12.2		
NOM EFF.	91.7	P.F.	0.84	INSULATION CLASS	F		
RATING CONT	S1	S.F.	1.15	MAX AMB.	40° C	WEIGHT	366 LBS.
DOWN THRUST	2500		ENCLOSURE TYPE	WP1			
UPPER BEARING	6210		BOTTOM BEARING	7310B			
LUBRICATION	MOBILE POLYREX EM		LUBRICATION	MOBILE POLYREX EM			
NON-REVERSE RATCHET - BALL TYPE			SERIAL NO.				
Specifically designed for use on deep well turbine pump applications. Hernando, Mississippi						PART WIND START CAPABLE @ 230V	

APPLICATIONS:

Specifically designed for use on deep well turbine pump applications. The coupling is equipped with a non-reverse ratchet, which prevents motor rotation from backspin at shutdown. These motors are built to NEMA standards and have special bearing arrangements to carry heavy thrust loads.