

**PEXP256T-10-6**

**EXPLOSION PROOF ELECTRIC MOTOR**

**NEMA PREMIUM EFFICIENCY**

**TOTALLY ENCLOSED FAN COOLED; EXPLOSION PROOF ENCLOSURE**

**CLASS I DIVISION I GROUP C & D; CLASS II DIVISION I GROUP F & G**

**OPERATING TEMP CODE T3C**

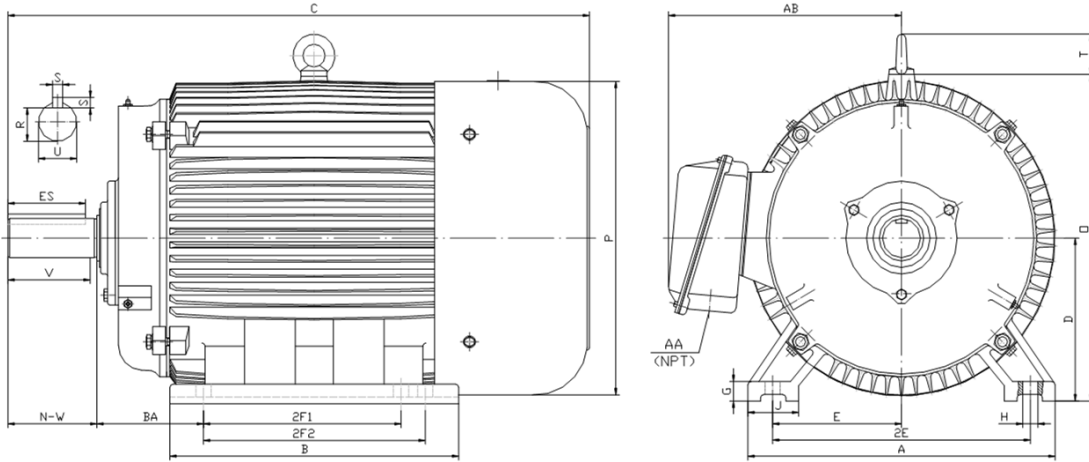

**DIMENSIONS**

HP	RPM	Frame	MOUNTING														
			A	B	C	D	G	H	J	E	2E	2F1	2F2	O	P	T	BA
10	1200	256T	13.00	12.20	25.00	6.25	0.70	0.53	2.75	5.00	10.00	8.25	10.00	13.20	12.80	2.20	4.25

Shaft Extension, Key Set						Conduit Box		Bearings		Mount
U	V	R	S	ES	N-W	AA	AB	DE	ODE	
1.63	3.75	1.42	0.38	2.91	4.00	1.25	10.30	6309	6309	F1

**BEARING LUBRICATION:** The bearings come lubricated with Mobil Polyrex EM Polyurea Grease. It is recommended that you add some additional lubrication when the motor is installed.

Three options (brands) for suitable lubrication include, but are not limited to, the following:

- 1.) Mobil Polyrex EM
- 2.) Citco Polyurea MP
- 3.) Conoco Phillips Polytac EP









**PEXP256T-10-6**
**EXPLOSION PROOF ELECTRIC MOTOR**
**NEMA PREMIUM EFFICIENCY**
**TOTALLY ENCLOSED FAN COOLED; EXPLOSION PROOF ENCLOSURE**
**CLASS I DIVISION I GROUP C & D; CLASS II DIVISION I GROUP F & G**
**OPERATING TEMP CODE T3C**
**PERFORMANCE DATA**

HP	RPM	Frame	Voltage	Frequency (Hz)	Full Load S.F.	Insulation Class	NEMA Design	Slip (%)	NEMA Code	Enclosure Type	IP Rating	Max. Ambient	Oper Temp Code	Max. KVAR
10	1186	256T	208-230/460	60	1.15	F	B	1.2	H	TEXP	55	40° C	T3C	2.9

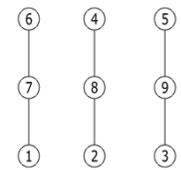
Amps (460V)		Max. Amps (208V)	Efficiency (%)				Power Factor			Torque (ft-lb)			DE Bearing	ODE Bearing	Connection	Weight (lbs.)
FLA	LRA	60HZ	100%	75%	50%	Min.	100%	75%	50%	FLT	LRT %	BDT %				
12.5	81.0	27.6	91.0	90.0	89.0	89.5	0.81	0.81	0.71	44.3	150	200	6309	6309	9 Lead 2Δ/Δ	384

**NAME PLATE**

 <b>North American Electric, Inc.</b>				<b>PREMIUM EFFICIENT EXPLOSION PROOF MOTOR</b>		<b>CONNECTION DIAGRAMS</b>		
<b>CAT NO:</b> PEXP256T-10-6		<b>FRAME:</b> 256T						<b>PHASE:</b> 3
<b>DE BRG:</b> 6309		<b>ODE BRG:</b> 6309		<b>CONN.:</b> 9 Lead 2Δ/Δ		<b>208V-230V</b>		
<b>MAX AMB.:</b> 40° C		<b>INS. CLASS:</b> F		<b>RATING CONT:</b>		<b>WEIGHT:</b> 384		
<b>USABLE ON 208V 60HZ AT:</b> 27.6		<b>MAX AMPS:</b>		<b>SER:</b>				
<b>DIVISION 1 CLASS I GROUP C D CLASS II GROUP F G</b>				<b>OPER TEMP CODE:</b> T3C				
<b>60 HERTZ DATA</b>	<b>HP:</b> 10		<b>RPM:</b> 1186		<b>HP:</b> 10		<b>RPM:</b> 988	
	<b>VOLTS:</b> 208-230/460				<b>VOLTS:</b> 190/380			
	<b>F.L. AMPS:</b> 27.6 - 25 / 12.5				<b>F.L. AMPS:</b> 30.3/15.2			
	<b>S.F. AMPS:</b> 14.4				<b>S.F. AMPS:</b> 30.3/15.2			
	<b>S.F.:</b> 1.15 DESIGN B CODE H				<b>S.F.:</b> 1.0 DESIGN B CODE H			
	<b>NEMA NOM.EFF.:</b> 91.0 % P.F. 0.81				<b>NEMA NOM.EFF.:</b> 89.0 % P.F. 0.81			
	<b>NEMA MIN.EFF.:</b> 89.5 %				<b>NEMA MIN.EFF.:</b> 86.8 %			
<b>MAX. KVAR:</b> 2.9		<b>LUB.:</b> Mobil Polyrex EM						
<small>General purpose use on industrial machinery installed in damp, dusty or dirty environments. These motors are designed for use in hazardous locations defined by class and group.</small>								
						<b>CC 041B</b>		
Hernando, Mississippi								

	<b>ELECTRIC MOTORS FOR HAZARDOUS LOCATIONS</b>
	<b>CLASS I DIVISION I GROUP C D, CLASS II DIVISION I GROUP F G</b>
	<b>NO. CCXXXXX E310089</b>

**APPLICATIONS:**

General purpose use on pumps, fans, blowers, compressors, conveyors, material handling and other industrial machinery installed in damp, dusty or dirty environments. These motors are designed to be used in hazardous locations as defined by class and group.