

**PE215JP-15-2**

**CLOSE COUPLED PUMP MOTORS**

**NEMA PREMIUM EFFICIENCY**

**THREE PHASE, TOTALLY ENCLOSED FAN COOLED, JP FRAME**

**INVERTER DUTY 10:1 CT; 20:1 VT - NEMA MG1 PART 31**

Factory Certified for T2B Class I, Division II, Groups A,B,C & D and Class II, Division II, Groups F & G

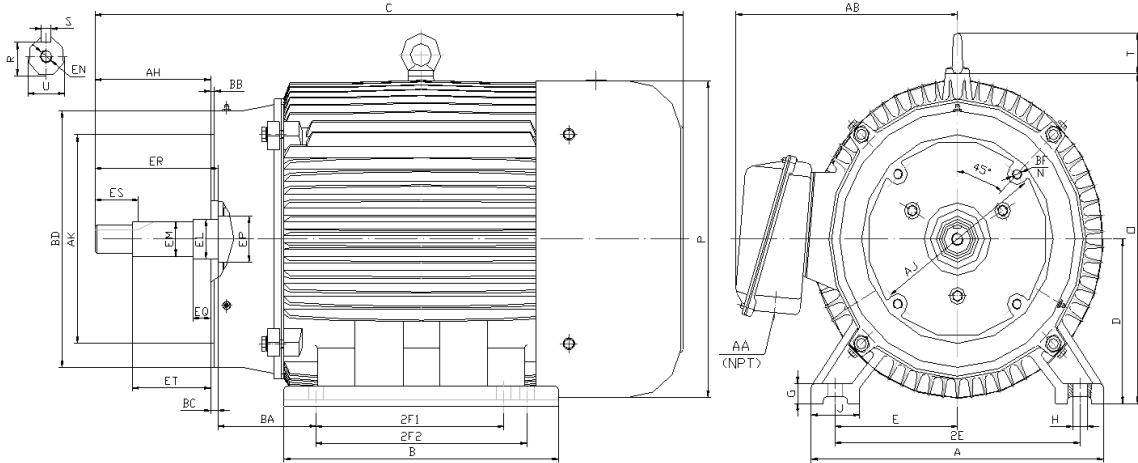

**DIMENSIONS**

HP	RPM	Frame	MOUNTING														
			A	B	C	D	G	H	J	E	2E	2F1	2F2	O	P	T	BA
15	3600	215JP	11.00	9.40	26.15	5.25	0.70	0.41	2.40	4.25	8.50	5.50	7.00	10.50	10.20	1.90	4.25

FLANGE							Shaft Extension, Key Set										
AK	AJ	AH	BB	BC	BD	N*BF	U	R	S	EQ	ER	ES	ET	EP	EL	EM	EN
8.500	7.25	8.156	0.312	0.25	9.00	4*1/2-13	1.2495	1.112	0.252	2.390	8.13	2.53	5.890	1.77	1.750	1.3750	1/2-13
8.497		8.094	0.250				1.2490	1.097	0.250	2.360			5.860		1.748	1.3745	

Conduit Box		Bearings		Mount
AA	AB	DE	ODE	
1.00	8.30	6309-ZZ	6308-ZZ	

**BEARING LUBRICATION:** The bearings come lubricated with Mobil Polyrex EM Polyurea Grease.





## PE215JP-15-2

**CLOSE COUPLED PUMP MOTORS**

**NEMA PREMIUM EFFICIENCY**

**THREE PHASE, TOTALLY ENCLOSED FAN COOLED, JP FRAME**

**INVERTER DUTY 10:1 CT; 20:1 VT - NEMA MG1 PART 31**

Factory Certified for T2B Class I, Division II, Groups A,B,C & D and Class II, Division II, Groups F & G

### PERFORMANCE DATA

HP	RPM	Frame	Voltage	Frequency (Hz)	Full Load S.F.	Insulation Class	NEMA Design	Slip (%)	NEMA Code	Enclosure Type	IP Rating	Max. Ambient
15	3510	215JP	208-230/460	60	1.15	F	B	2.5	G	TEFC	55	40° C

Amps (460V)		Efficiency (%)				Power Factor			Torque (ft-lb)			DE Bearing	ODE Bearing	Connection	Weight (lbs.)
FLA	LRA	100%	75%	50%	Min.	100%	75%	50%	FLT	LRT %	BDT %				
17.5	116.0	91.0	91.0	90.5	89.5	0.910	0.890	0.830	22.4	170	280	6309-ZZ	6308-ZZ	9 Lead 2Y/Y	189

### NAME PLATE

													<b>CONNECTION DIAGRAMS</b>  <b>208-230V</b> 				
<b>INVERTER DUTY 20:1 VT; 10:1 CT</b>										<b>CLOSE COUPLED PUMP MOTOR</b>							
CAT NO:		PE215JP-15-2				FRAME		215JP		PHASE		3		<b>460V</b> 			
HZ	60	S.F.	1.15	HZ	50	S.F.	1.0	ENCL	TEFC	IP	55						
HP	15	RPM	3510	HP	15	RPM	2890	DUTY	CONT	DES	B						
VOLTS		208-230/460				VOLTS		190/380		AMB		40° C		INS		F	
FLA	37 - 35 / 17.5		FLA		42/21		DE BEARING		6309-ZZ		ODE BEARING		6308-ZZ				
CODE	G	P.F.	0.91	CODE	E	P.F.	0.92	LUB:		Mobil Polyrex EM							
EFF		91.0		MIN	89.5		EFF	89		MIN	87.5		SER NO				
MOTOR WEIGHT		189		LBS	CONNECTION		9 Lead 2Y/Y										
Specifically designed for use on industrial and commercial pumping units.  Hernando, Mississippi																CC 082A	

### APPLICATIONS:

Specifically designed for use on industrial and commercial pumping units.