

PR56C1M2A

GENERAL PURPOSE ELECTRIC MOTOR
NEMA PREMIUM EFFICIENCY
TOTALLY ENCLOSED FAN COOLED
ROLLED STEEL CONSTRUCTION
INVERTER RATED (10:1 VT; 5:1 CT)

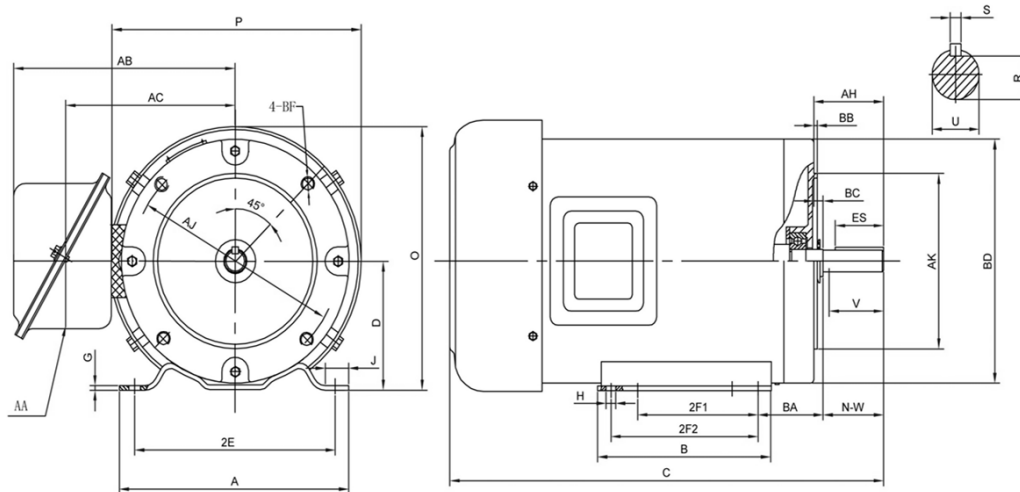

DIMENSIONS

HP	RPM	Frame	MOUNTING															
			A	B	C	D	G	H	J	E	2E	2F1	2F2	O	P	T	BA	
1	3600	56C	6.30	3.94	11.80	3.50	0.12	0.35	1.46	2.44	4.88	3.00	NA	7.00	6.97	NA	2.75	

FLANGE							Shaft Extension, Key Set						
AH	AJ	AK	BB	BC	BD	BF	U	V	R	S	ES	N-W	
2.07	5.875	4.50	0.16	-0.19	6.50	3/8-16UNC	0.625	1.50	0.517	0.188	1.38	1.88	

Conduit Box		Bearings		Mount
AA	AB	DE	ODE	
0.80	6.30	6203	6203	F1

BEARING LUBRICATION: The bearings come lubricated with Mobil Polyrex EM Polyurea Grease.



PR56C1M2A

GENERAL PURPOSE ELECTRIC MOTOR
NEMA PREMIUM EFFICIENCY
TOTALLY ENCLOSED FAN COOLED
ROLLED STEEL CONSTRUCTION
INVERTER RATED (10:1 VT; 5:1 CT)

PERFORMANCE DATA

HP	RPM	Frame	Voltage	Frequency (Hz)	Full Load S.F.	Insulation Class	NEMA Design	Slip (%)	NEMA Code	Enclosure Type	IP Rating	Max. Ambient
1	3500	56C	208-230/460	60	1.15	F	B	0.028	K	TEFC	IP44	40°C

Amps (460V)		Efficiency (%)			Power Factor			Torque (ft-lb)			DE Bearing	ODE Bearing	Connection	Weight (lbs.)
FLA	LRA	100%	75%	50%	100%	75%	50%	FLT	LRT %	BDT %				
1.6	10.4	82.5	81.4	77.8	0.76	0.67	0.55	2.03	236	365	6203-2RZC3	6203-2RZC3	9 Lead Y	21

NAME PLATE															
North American Electric, Inc.						GENERAL PURPOSE <div style="display: flex; justify-content: center; align-items: center;"> <div style="text-align: center; margin-right: 10px;"> NEMA Premium </div> </div> TOTALLY ENCLOSED FAN COOLED									
MODEL		HP		1		RPM		3500		FRAME		56C			
PR56C1M2A		ENCL		TEFC		HZ		60		PHASE		3			
VOLT		208-230/460		AMPS		4.0-3.6/1.8		S.F.		1.15		DESIGN		B	
S.F. AMPS		4.6-4.1/2.1		CLASS		F		CODE		K		LBS		21	
DE BEARING				6203-2RZC3											
ODE BEARING				6203-2RZC3											
RATING		CONT		MAX AMB.		40°C									
SER															
Hernando, MS www.naemotors.com															

4	5	6		4	5	6
7	8	9		7	8	9
1	2	3		1	2	3
↑	↑	↑		↑	↑	↑
230V LINE				460V LINE		

APPLICATIONS:

General purpose use on pumps, fans, blowers, compressors, conveyors, material handling and other industrial machinery installed in damp, dusty or dirty environments.