

F56C3/4M4D

GENERAL PURPOSE ELECTRIC MOTOR
 HIGH EFFICIENCY / EISA COMPLIANT
 TOTALLY ENCLOSED FAN COOLED
 ROLLED STEEL CONSTRUCTION
 INVERTER RATED (10:1 VT; 5:1 CT)

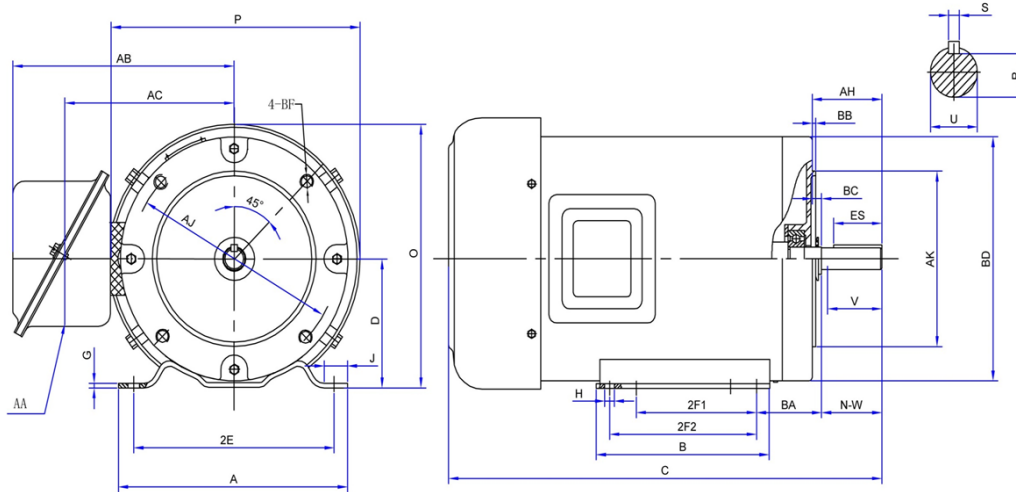

DIMENSIONS

HP	RPM	Frame	MOUNTING														
			A	B	C	D	G	H	J	E	2E	2F1	2F2	O	P	T	BA
3/4	1800	56C	6.30	3.94	11.80	3.50	0.12	0.35	1.46	2.44	4.88	3.00	NA	7.00	6.97	NA	2.75

FLANGE							Shaft Extension, Key Set						
AH	AJ	AK	BB	BC	BD	BF	U	V	R	S	ES	N-W	
2.07	5.875	4.50	0.16	-0.19	6.50	3/8-16UNC	0.625	1.50	0.517	0.188	1.38	1.88	

Conduit Box		Bearings		Mount
AA	AB	DE	ODE	
0.80	6.30	6203	6203	F1

BEARING LUBRICATION: The bearings come lubricated with Mobile Polyrex EM Polyurea Grease.



F56C3/4M4D

GENERAL PURPOSE ELECTRIC MOTOR
HIGH EFFICIENCY / EISA COMPLIANT
TOTALLY ENCLOSED FAN COOLED
ROLLED STEEL CONSTRUCTION
INVERTER RATED (10:1 VT; 5:1 CT)

PERFORMANCE DATA

HP	RPM	Frame	Voltage	Frequency (Hz)	Full Load S.F.	Insulation Class	NEMA Design	Slip (%)	NEMA Code	Enclosure Type	IP Rating	Max. Ambient
3/4	0	56C	575	60HZ	1.15	F	B	0	0	TEFC	IP44	40°C

Amps (460V)		Efficiency (%)			Power Factor			Torque (ft-lb)			DE Bearing	ODE Bearing	Connection	Weight (lbs.)	
FLA	LRA	100%	75%	50%	100%	75%	50%	FLT	LRT %	BDT %					
0	0	0.0	0	0	0	0.00	0	0.00	0	0	0	0	0	3 Lead	0

NAME PLATE											
						GENERAL PURPOSE HIGH EFFICIENCY DESIGN TOTAL ENCLOSED FAN COOLED					
THREE PHASE ELECTRIC MOTOR											
MODEL	HP	3/4	RPM	0	FRAME	56C					
F56C3/4M4D	ENCL	TEFC	HZ	60HZ	PHASE	3					
VOLT	575	AMPS	0	S.F.	1.15	DESIGN	B				
S.F. AMPS	0	CLASS	F	CODE	0	LBS	0				
DE BEARING	0										
ODE BEARING	0										
RATING	CONT	MAX AMB.									
SER											
Hernando, MS www.naemotors.com											

APPLICATIONS:

General purpose use on pumps, fans, blowers, compressors, conveyors, material handling and other industrial machinery installed in damp, dusty or dirty environments.