

## F56C1/2M4D

GENERAL PURPOSE ELECTRIC MOTOR  
 HIGH EFFICIENCY / EISA COMPLIANT  
 TOTALLY ENCLOSED FAN COOLED  
 ROLLED STEEL CONSTRUCTION  
 INVERTER RATED (10:1 VT; 5:1 CT)

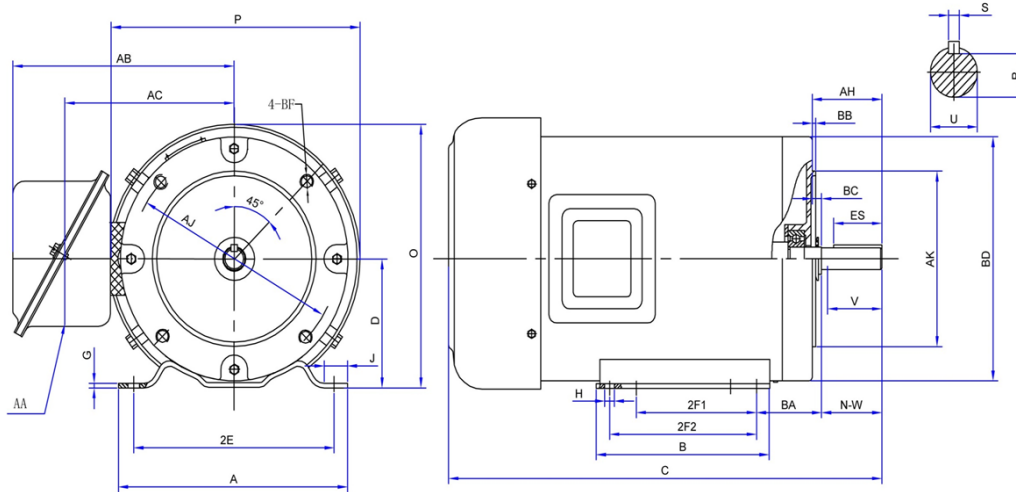

### DIMENSIONS

HP	RPM	Frame	MOUNTING														
			A	B	C	D	G	H	J	E	2E	2F1	2F2	O	P	T	BA
1/2	1800	56C	6.30	3.94	11.80	3.50	0.12	0.35	1.46	2.44	4.88	3.00	NA	7.00	6.97	NA	2.75

FLANGE							Shaft Extension, Key Set						
AH	AJ	AK	BB	BC	BD	BF	U	V	R	S	ES	N-W	
2.07	5.875	4.50	0.16	-0.19	6.50	3/8-16UNC	0.625	1.50	0.517	0.188	1.38	1.88	

Conduit Box		Bearings		Mount
AA	AB	DE	ODE	
0.80	6.30	6203	6203	

**BEARING LUBRICATION:** The bearings come lubricated with Mobile Polyrex EM Polyurea Grease.



## F56C1/2M4D

**GENERAL PURPOSE ELECTRIC MOTOR**  
**HIGH EFFICIENCY / EISA COMPLIANT**  
**TOTALLY ENCLOSED FAN COOLED**  
**ROLLED STEEL CONSTRUCTION**  
**INVERTER RATED (10:1 VT; 5:1 CT)**

### PERFORMANCE DATA

HP	RPM	Frame	Voltage	Frequency (Hz)	Full Load S.F.	Insulation Class	NEMA Design	Slip (%)	NEMA Code	Enclosure Type	IP Rating	Max. Ambient
1/2	1765	56C	575	60HZ	1.15	F	B	1.9	J	TEFC	IP44	40°C

Amps (460V)		Efficiency (%)			Power Factor			Torque (ft-lb)			DE Bearing	ODE Bearing	Connection	Weight (lbs.)
FLA	LRA	100%	75%	50%	100%	75%	50%	FLT	LRT %	BDT %				
1.01	5	63.6	62	59.1	0.58	0.51	0.397	2.01	208	531	6203-2RZC3	6203-2RZC3	3 Lead	21

NAME PLATE											
						<b>GENERAL PURPOSE</b>  <b>HIGH EFFICIENCY DESIGN</b>  <b>TOTAL ENCLOSED FAN COOLED</b>					
<b>THREE PHASE ELECTRIC MOTOR</b>											
MODEL	HP	1/2	RPM	1765	FRAME	56C					
F56C1/2M4D	ENCL	TEFC	HZ	60HZ	PHASE	3					
VOLT	575	AMPS	0.8	S.F.	1.15	DESIGN	B				
S.F. AMPS	1.05	CLASS	F	CODE	J	LBS	21				
DE BEARING	6203-2RZC3										
ODE BEARING	6203-2RZC3										
RATING	CONT	MAX AMB.	40°C								
SER											
Hernando, MS www.naemotors.com											

### APPLICATIONS:

General purpose use on pumps, fans, blowers, compressors, conveyors, material handling and other industrial machinery installed in damp, dusty or dirty environments.