

PE587UZ-400-6C

CRUSHER DUTY MOTOR

HIGH TORQUE / PREMIUM EFFICIENCY DESIGN

TOTALLY ENCLOSED FAN COOLED

HEAVY DUTY CAST IRON CONSTRUCTION

Factory Certified for T2B Class I, Division II, Groups A,B,C & D and Class II, Division II, Groups F & G

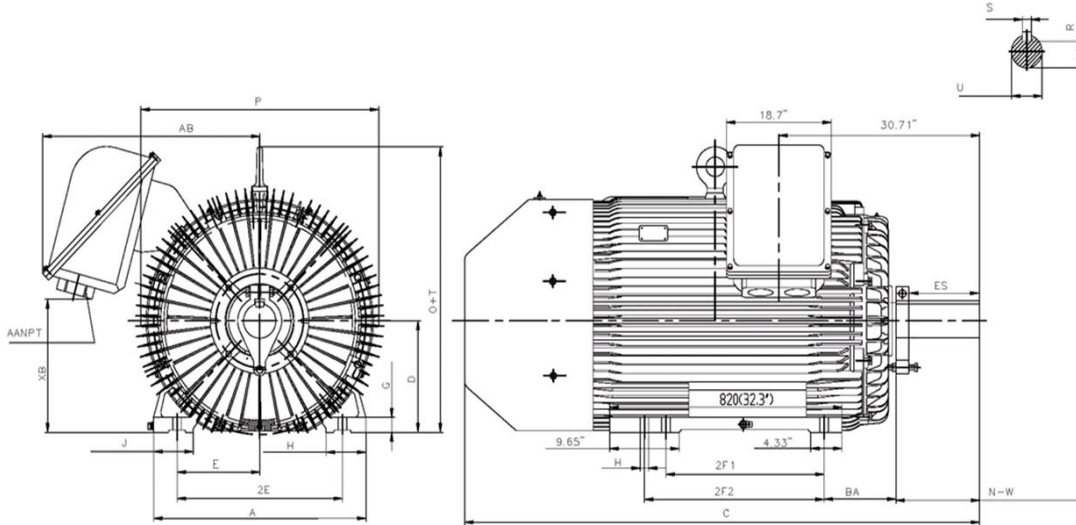

DIMENSIONS

HP	RPM	Frame	MOUNTING														
			A	B	C	D	G	H	J	E	2E	2F1	2F2	O	P	T	BA
400	1200	587UZ	29.53	32.38	71.65	14.50	1.97	1.13	5.51	11.50	23.00	22.00	25.00	41.36	33.07	5.88	10.00

Shaft Extension, Key Set				Conduit Box		Bearings		Mount		
U	V	R	S	ES	N-W	AA	AB		DE	ODE
4.375	11.25	3.817	1.00	10.00	11.63	2 X 3"	28.15	NU324	6319	F1

BEARING LUBRICATION: The bearings come lubricated with Mobil Polyrex EM Polyurea Grease. It is recommended that you add some additional lubrication when the motor is installed.

Three options (brands) for suitable lubrication include, but are not limited to, the following:

- 1.) Mobil Polyrex EM
- 2.) Citco Polyurea MP
- 3.) Conoco Phillips Polytac EP





PE587UZ-400-6C

CRUSHER DUTY MOTOR
HIGH TORQUE / PREMIUM EFFICIENCY DESIGN
TOTALLY ENCLOSED FAN COOLED
HEAVY DUTY CAST IRON CONSTRUCTION

Factory Certified for T2B Class I, Division II, Groups A,B,C & D and Class II, Division II, Groups F & G

PERFORMANCE DATA

HP	RPM	Frame	Voltage	Frequency (Hz)	Full Load S.F.	Insulation Class	NEMA Design	Slip (%)	NEMA Code	Enclosure Type	IP Rating	Max. Ambient
400	1189	587UZ	460	60	1.15	F	C	0.9	G	TEFC	55	40° C

Amps (460V)		Efficiency (%)				Power Factor			Torque (ft-lb)			DE Bearing	ODE Bearing	Connection	Weight (lbs.)
FLA	LRA	100%	75%	50%	Min.	100%	75%	50%	FLT	LRT %	BDT %				
448.6	2900	95.8	95.5	95.0	95.0	0.859	0.833	0.767	2411	200	230	NU324	6319	12 Lead Δ	5940

NAME PLATE

										CONNECTION DIAGRAMS Across The Line 							
CAT NO: PE587UZ-400-6C			FRAME 587UZ			PHASE 3											
DE BRG NU324		ODE BRG 6319		CONN. 12 Lead Δ													
MAX AMB. 40° C		INS. CLASS F		RATING CONT		WEIGHT 5940											
LUBRICATION Mobil Polyrex EM				SER													
60 HERTZ DATA	HP 400		RPM 1189		HP 400		RPM 990				50 HERTZ DATA	PWS Start 					
	VOLTS 460				VOLTS 380												
	F.L. AMPS 448.6				F.L. AMPS 543.0												
	S.F. AMPS 515.9				S.F. AMPS 543.0												
	S.F. 1.15 DESIGN C CODE G				S.F. 1.0 DESIGN C CODE H												
	NEMA NOM.EFF. 95.8 %		NOM. P.F. 0.859		NEMA NOM.EFF. 95.0 %		NOM. P.F. 0.859										
NEMA MIN.EFF. 95.0 %		MAX. KVAR 64.7		NEMA MIN.EFF. 94.3 %		MAX. KVAR 66.2											
Designed specifically for use on crushing and pulverizing equipment and other equipment requiring extremely high starting torques and breakdown torques.										CC041B							
Hernando, MS 38632																	

APPLICATIONS:

Special purpose use on crushing and pulverizing equipment and other industrial equipment requiring extremely high starting torques and breakdown torques.