

# Product Information Packet

January 12, 2017

Data shown is for the current revision model #. Ensure your nameplate model # matches.

<b>Model Number:</b>	<b>5KS511SAA338C</b>
<b>Catalog Number:</b>	<b>Q516</b>
<b>Instruction Manual:</b>	GEI-56128
<b>Connection Diagram:</b>	GEM2034E-FIG2
<b>Outline Drawing:</b>	239C6B00MD

Accessory Connection Diagrams			
<b>Bearing Thermocouple:</b>	None	<b>Heater:</b>	3027JE-1C
<b>RTD:</b>	235A3027XY	<b>Thermistor:</b>	None
<b>Thermostat:</b>	None	<b>Winding Thermocouple:</b>	None
<b>Bearing RTD:</b>	235A3027NA		

Table of Contents	
Specification	01
Performance Characteristics	02
Outline Drawing	03
Connection Drawing(s)	04

**Marks:**

<b>MODEL NUMBER:</b>	<b>5KS511SAA338C</b>	<b>Estimated Weight:</b>	5335 Lbs
<b>Outline Drawing:</b>	239C6B00MD	<b>Time Rating:</b>	CONT
<b>Connection Diagram:</b>	GEM2034E-FIG2	<b>Enclosure:</b>	TEFC
<b>Instruction Book:</b>	GEI-56128	<b>Encl Construction:</b>	SD
<b>Design Code:</b>	50BD3186E	<b>Ambient Max(°C):</b>	40
<b>Type:</b>	KS	<b>Alt Ambient Max(°C):</b>	--
<b>Frame:</b>	5011L	<b>Insulation Class:</b>	F
<b>Phases:</b>	3	<b>NEMA Design:</b>	B
<b>Poles:</b>	6	<b>Nominal Efficiency:</b>	95.4 %
<b>Output Power:</b>	300HP 222KW	<b>Guaranteed Efficiency:</b>	94.5
<b>RPM:</b>	1185	<b>3/4 Load Efficiency:</b>	95.8
<b>Voltage:</b>	2300/4000	<b>KVA Code:</b>	G
<b>Hertz:</b>	60	<b>Max KVAR:</b>	85.3
<b>Amps - FL:</b>	69.7/40.1	<b>Power Factor:</b>	84.5
<b>Service Factor:</b>	1.15	<b>Bearing - DE:</b>	NU 320
<b>Alt Service Factor:</b>	--	<b>Bearing - ODE:</b>	6315ZC3

**Enclosure is Totally Enclosed Fan-Cooled**

---

**Stamped Nameplate Notes:**

HTR LDS HE1-HE2 115V 350W  
 ROLLER BEARING - FOR BELTED LOAD ONLY

**Additional Information:**

6P - L EXTN  
 2500 CU IN - 2(4.00" NPT)  
 B5F4C4 HIGH STRENGTH STEEL AISI 4142 SHAFT MATERIAL  
 100 OHM WINDING RTD LEADS TO AUX C/BOX OPP MAIN C/BOX  
 SUGGESTED WINDING RTD SETTINGS  
 ALARM 165C TRIP 175C  
 115V HTR LDS TO AUX BOX OPP MAIN CONDUIT BOX  
 SPACE HEATER CAUTION NAMEPLATE  
 BEARING RTD 100 OHM ON BOTH ENDS  
 SUGGESTED BEARING RTD SETTINGS  
 ALARM 115C TRIP 125C  
 NEMA TYPE GRD PAD  
 F1 MOUNTING  
 SHAFT BLOCKING FOR SHIPMENT

**Performance Characteristics**

1st Winding 1st Connection

**Design: 50BD3186E**

**Marks:**

LOAD %	125.0	115.0	100.0	75.0	50.0	25.0	0.0
% EFF	94.92	95.16	95.67	95.76	95.54	93.5	0.00
% PF	85.43	85.22	84.43	81.17	72.86	51.39	3.48
AMPS	49.78	45.79	40	31.16	23.19	16.8	13.68

<b>TORQ(FL)#FT</b>	1328.8	<b>TORQ(LR)%FL</b>	121.98	<b>TORQ(BD)%FL</b>	261.12
<b>AMPS(LR)</b>	232.45	<b>PF AT START</b>	0.26		

This motor is capable of two cold or one hot start with a maximum connected load inertia of 17332 Lb-Ft Sq (729.68 Kg-meter Sq)at 100% voltage, where the load torque varies with the square of the speed. Acceleration time with maximum inertia and the above load type is 47 seconds. Safe stall time at 100% voltage is 99 seconds cold, 59 seconds hot. Rotor inertia is 230.95 Lb-Ft Sq (9.72 Kg-meter Sq).

<b>Open Circuit A-C:</b>	0.62	<b>Short Circuit D-C:</b>	0.035
<b>Short Circuit A-C:</b>	0.035	<b>X/R Ratio:</b>	13.179
<b>Stator Slots:</b>	72	<b>Rotor Slots:</b>	58

**Speed Torque Current Curve (First Connection, First Speed)**

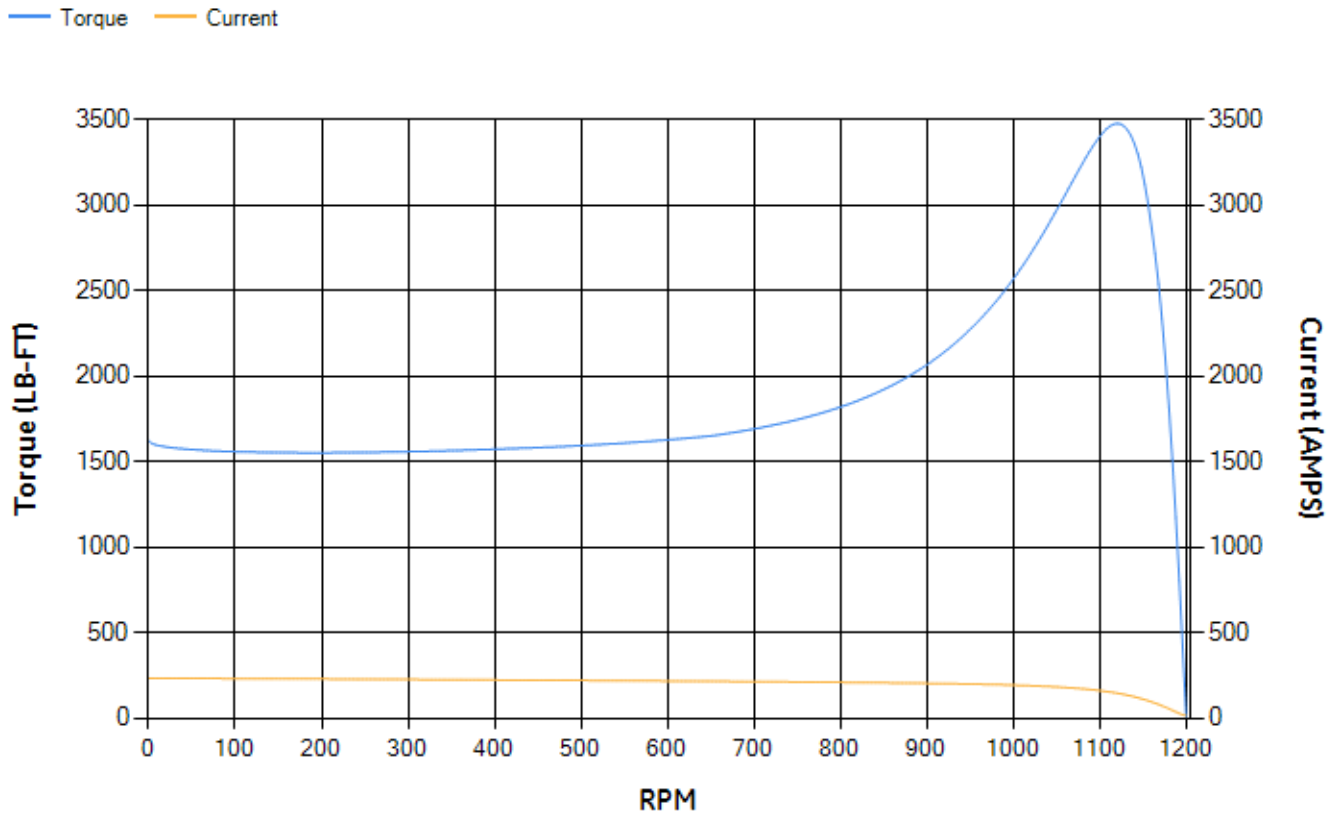

Marks:

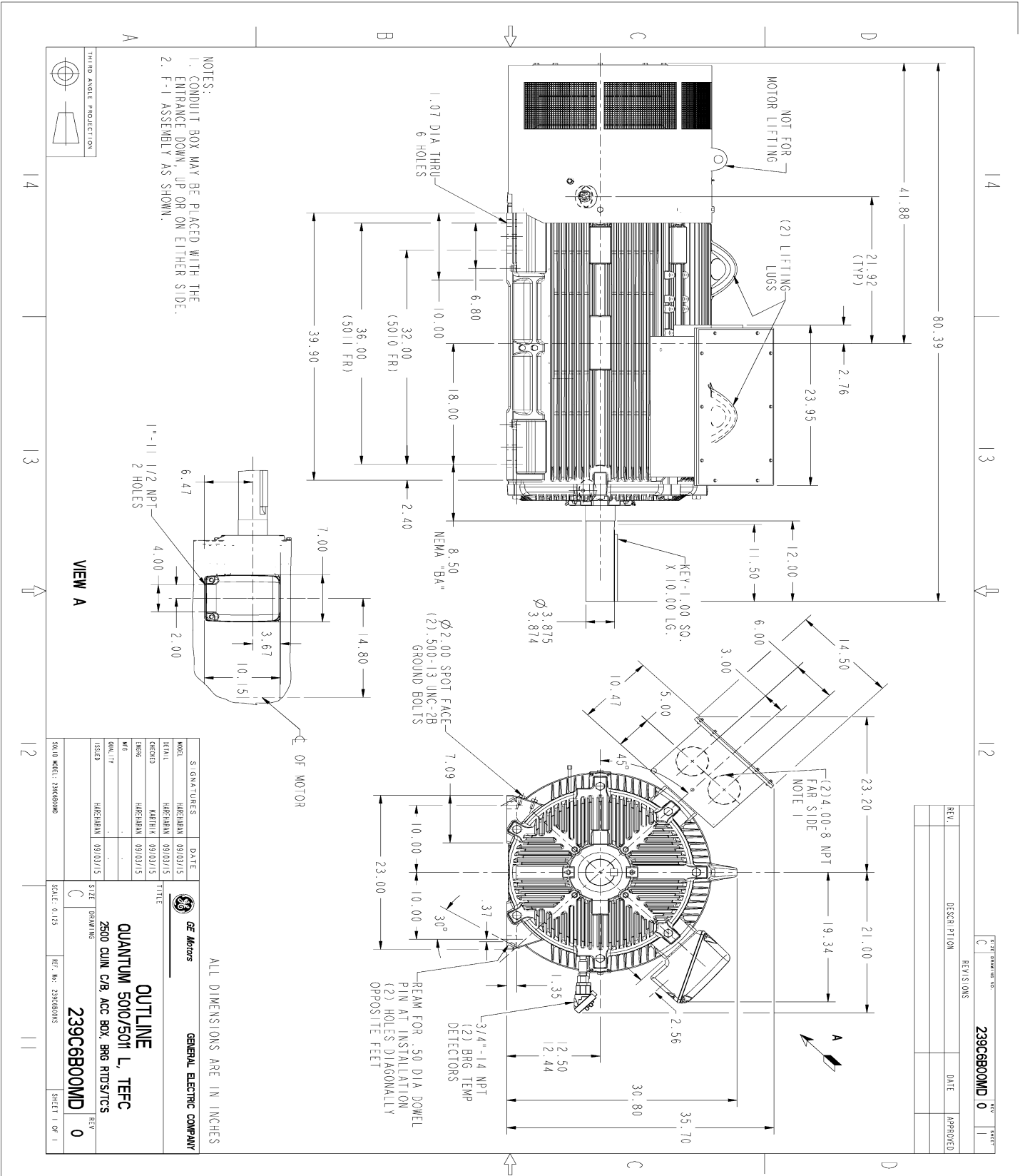

NOTES:  
 1. CONDUIT BOX MAY BE PLACED WITH THE ENTRANCE DOWN, UP OR ON EITHER SIDE.  
 2. F-1 ASSEMBLY AS SHOWN.

VIEW A

ALL DIMENSIONS ARE IN INCHES

SIGNATURES		DATE	
MODEL	HAEHRMAN	09/03/15	
DESIGN	HAEHRMAN	09/03/15	
DRWG	HAEHRMAN	09/03/15	
CHKD	HAEHRMAN	09/03/15	
APPV	HAEHRMAN	09/03/15	

TITLE	
<b>OUTLINE</b> <b>QUANTUM 5010/5011 L, TEFC</b> <b>2500 CUIN C/B, ACC BOX, BRG RTD/STCS</b>	
SCALE: 0.125	REV: 0
REF. NO: 239C6B00MD	SHEET 1 OF 1

REV.	DESCRIPTION	DATE	APPROVED

SIZE	239C6B00MD	REV	0	SHEET	1
REV	C	REV	0	DATE	

Marks:

**Connection Diagram**  
**GEM2034E-FIG2**

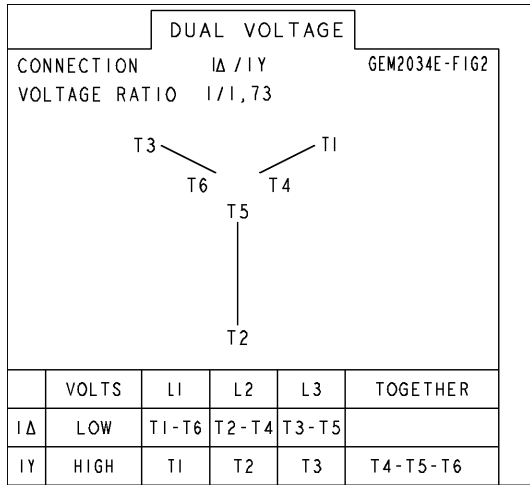

**Heater Connection**  
**3027JE-1C**



GE PROPRIETARY INFORMATION

This document is the property of General Electric Company ("GE") and contains proprietary information of GE. This document is loaned on the express condition that neither it nor the information contained herein shall be disclosed to others without the express written consent of GE Industrial Systems, and that the information shall be used by the recipient only as approved expressly by GE Industrial Systems. This document shall be returned to GE upon its request. This document may be subject to certain restrictions under U.S. export control laws and regulations.

THIRD ANGLE PROJECTION

REVISIONS				
REV.	DESCRIPTION	DATE	APPROVED	
1	ISAAC# 15-0790 HARIKIRAN	07/28/15	DHEERAJ	
2	ISAAC# 16-0422 SAGAR K	05/04/2016	ADINARAYANA	

REV 2

SIZE DRAWING NO. A

235A3027XY

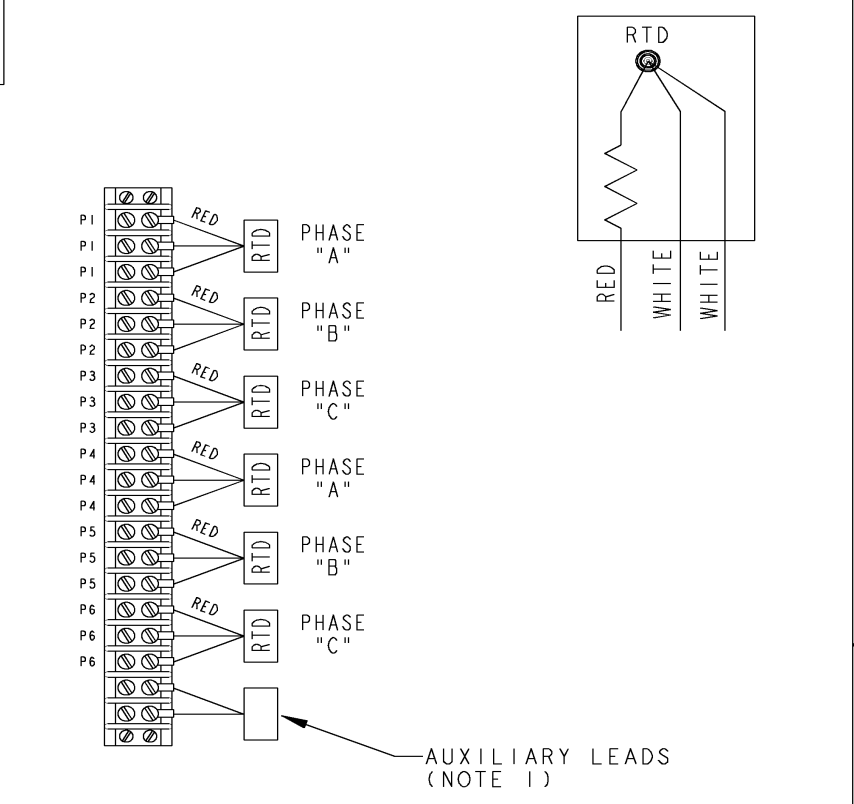

NOTE 1: AUXILIARY LEADS SHOWN MAY OR MAY NOT BE PROVIDED IN MOTOR.  
 NOTE 2: SPARE RTDS (P7 & P8) FURNISHED IN CASE OF FAILURE IN OTHER RTDS (P1-P6). PHASE LOCATION WILL DEPEND UPON NUMBER OF POLES WINDING CONFIGURATION.

Part must conform to SI 900000 Sect. 4, Toxicity Procedure

FOR ADDITIONAL INFO REFER TO:	SIGNATURES	DATE
APPLIED PRACTICES	MODEL	
DIMENSIONS ARE IN INCHES	DETAIL VIVEK	06/26/15
TOLERANCE ON:	CHECKED KARTHIK	06/26/15
1 PL DECIMALS ± 0.1	ENGRG	
2 PL DECIMALS ± 0.02	MFG	
3 PL DECIMALS ± 0.005	QUALITY	
ANGLES ± 0.5	ISSUED VIVEK	06/26/15
FRACTIONS ±		
FINISH ✓	SOLID MODEL: MODEL NAME	

**GE Motors** GENERAL ELECTRIC COMPANY

TITLE **CONNECTION DIAGRAM**  
**WINDING RTD & AUXILIARY LEADS**

SIZE DRAWING **A** **235A3027XY** REV **2**  
 SCALE: N.T.S. REF: - 235A4594X SHEET 1 of 1



REV SH	THIRD ANGLE PROJECTION		REVISIONS		
		REV	DESCRIPTION	DATE	APPROVED
	1	ISAAC #12-1124	HARI	11/19/12	KARTHIK

SIZE A  
 DWG NO 235A3027NA

**CONFIDENTIAL AND PROPRIETARY**  
 This document is the property of General Electric Company and contains proprietary and confidential information of the Motor Business Group (MBG). The document is loaned on the express conditions that neither it nor the information contained therein shall be disclosed to others without the express consent of MBG and that the information shall be used by the recipient only as approved expressly by MBG. Also, the document shall be returned to MBG upon its request.

## BEARING RTDS

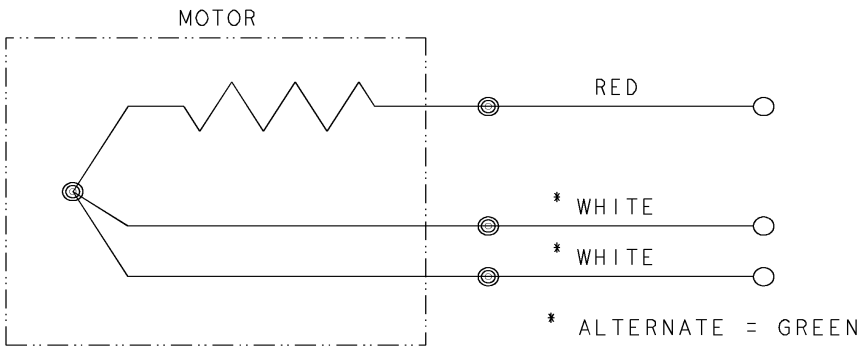

UNLESS OTHERWISE SPECIFIED	SIGNATURES	DATE
DIMENSIONS ARE IN INCHES	DRAWN D.E. BAIR	12/16/92
TOLERANCES ON:	CHECKED D.E. BAIR	12/16/92
2 PL DECIMALS ±	ENGRG K. DESAI	12/16/92
3 PL DECIMALS ±	ISSUED D.E. BAIR	12/16/92
ANGLES ±		
FRACTIONS ±		
MATERIAL:		
APPLIED PRACTICES:	CAD NO. F500:235A3027NA	

**GE Motors**

Fort Wayne, Indiana

## CONNECTION DIAGRAM

BEARING RTDS

SIZE A	FSCM NO	DWG NO 235A3027NA
SCALE 1/1	SHEET 1 OF 1	

DISTR TO