

# Product Information Packet

November 7, 2016

Data shown is for the current revision model #. Ensure your nameplate model # matches.

<b>Model Number:</b>	<b>5CD143MC003B040</b>
<b>Catalog Number:</b>	<b>D537</b>
<b>Instruction Manual:</b>	GEH-3967N
<b>Connection Diagram:</b>	36A167960CA501
<b>Outline Drawing:</b>	36B467421AA002

Accessory Connection Diagrams			
<b>Bearing Thermocouple:</b>	None	<b>Heater:</b>	None
<b>RTD:</b>	None	<b>Thermistor:</b>	None
<b>Thermostat:</b>	None	<b>Winding Thermocouple:</b>	None
<b>Bearing RTD:</b>	None		

Table of Contents	
Specification	01
Outline Drawing	02
Connection Drawing(s)	03

Marks:

<b>MODEL NUMBER:</b>	<b>5CD143MC003B040</b>
<b>Outline Drawing:</b>	36B467421AA002
<b>Connection Diagram:</b>	36A167960CA501
<b>Horsepower:</b>	2
<b>Armature Volts:</b>	180
<b>Wound:</b>	SHUNT
<b>Enclosure:</b>	DPFG
<b>Duty:</b>	CONT
<b>Rating Code:</b>	143M1340-00
<b>K(V):</b>	.92 Cemf volts/Radian/Sec
<b>K(T):</b>	.64 Ft/Amp
<b>Minimum Ambient:</b>	0 C

<b>Enclosure Mtg Assem:</b>	36A167770GA201
<b>Instruction Book:</b>	GEH-3967N
<b>RPM:</b>	1750/2050
<b>Armature Amps:</b>	9.4
<b>Type:</b>	CD186ATC
<b>Power Supply Code:</b>	K
<b>Insulation Class:</b>	F
<b>Ambient Max (°C):</b>	40 C
<b>Field Volts:</b>	200/100
<b>WK2:</b>	.45Lb Ft2
<b>Year of Manufacture:</b>	2016
<b>Max Altitude:</b>	3300 Ft

Resistances at 25 Degrees C :

<b>Shunt Field:</b>	244 OHMS
<b>Armature:</b>	.6242 OHMS
<b>Commutator Field:</b>	.3055 OHMS

Inductances:

<b>Armature Circuit Total:</b>	17.330 mH Saturated
<b>Shunt Field:</b>	124.0 Henries Unsaturated

Shunt Field Data:

Shunt Field Current(1): .59 AMPS at Rated Load and 1750 RPM  
 Shunt Field Current(2): .5 AMPS at Rated Load and 1850 RPM  
 Shunt Field Current(3): .39 AMPS at Rated Load and 2050 RPM

---

Additional Machine Notes:

DRIPPROOF FULLY GUARDED - BALL BEARINGS  
 STANDARD SHAFT DRIVE END ONLY - WITH FEET  
 WITH:  
 CSA STAMP  
 THERMOSTAT- NORMALLY CLOSED, AC RATING- 600V MAX-  
 .5A, 250V-1.5A, OR 125V-3A, DC RATING- 30V MAX-  
 1.5A. MAXIMUM CURRENT BASED ON INDUCTIVE LOADS UP  
 TO AND INCLUDING NEMA NO.5 CONTACTOR.

NAME:208009544 OBJECT:36B467421AA002 DATE:29-Apr-08 14:07:46

Marks:

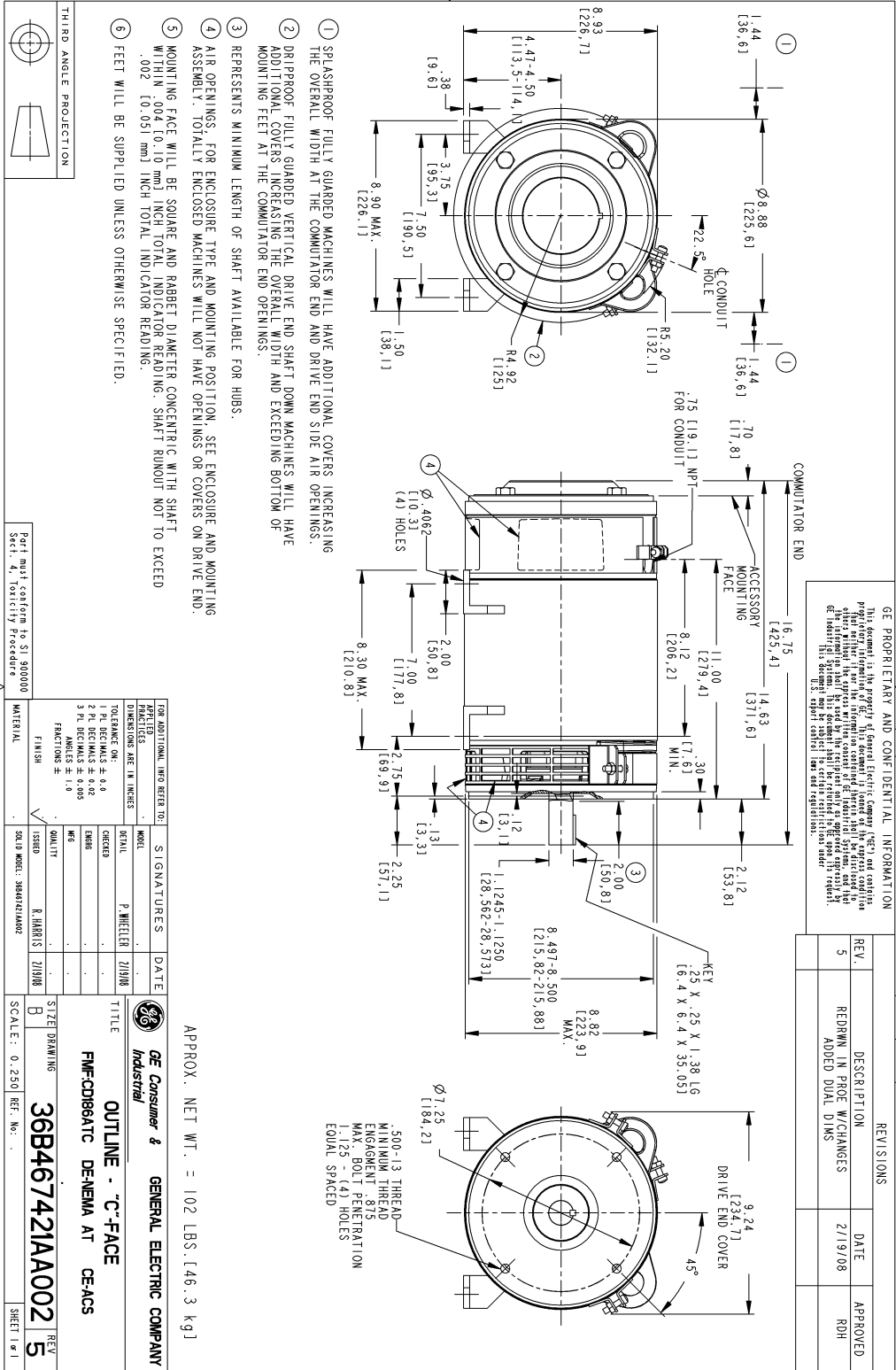

Marks:

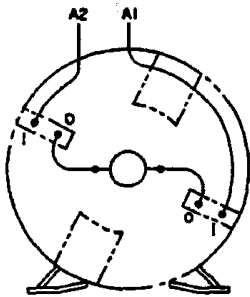
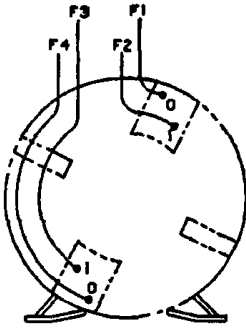
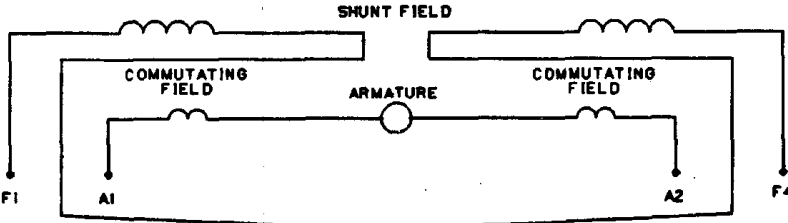
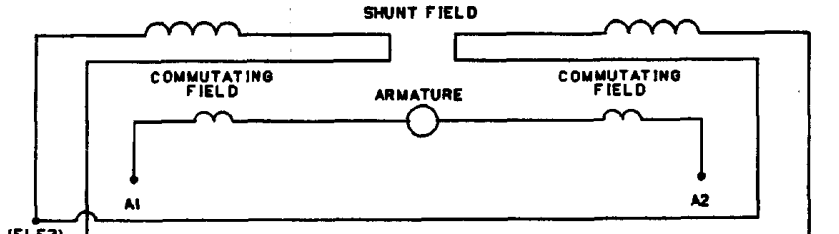
NO S.O.	<b>GENERAL ELECTRIC</b>	36A167960CA501 CONT ON SHEET SH NO.
REV 1 36A167960CA501 CONT ON SHEET SH NO.	<b>TITLE</b> <b>CONNECTION DIAGRAM</b>	
FIRST MADE FOR 180AT 2 POLE DIRECT CURRENT MOTOR AND GENERATOR - SHUNT WOUND 1 OR 2 CIRCUIT SHUNT FIELD, 1 CIRCUIT COMMUTATING FIELD		
VIEWS FACING COMMUTATOR END		
 <p>COMMUTATING FIELD AND ARMATURE</p>	 <p>SHUNT FIELD</p>	
<p>ALL EXTERNAL LEADS ARE MARKED. ALL CONNECTIONS AND TERMINATIONS EXTERNAL TO MAGNET FRAME MUST BE INSULATED PER NATIONAL ELECTRICAL CODE AND SOUND LOCAL PRACTICES.</p> <p>SPACE HEATERS, WHEN SPECIFIED, WILL HAVE LEADS WITH TERMINAL MARKINGS H1 AND H2.</p> <p>THERMOSTAT, WHEN SPECIFIED, WILL HAVE LEADS WITH TERMINAL MARKINGS P1 AND P2.</p> <p>ENCIRCLED NUMBERS MAY BE USED FOR PART IDENTIFICATION.</p>		
<p>FOR HIGH NAMEPLATE EXCITATION VOLTAGE CONNECT SHUNT FIELD LEADS AS INDICATED</p>	 <p style="text-align: center;">(F2,F3)</p>	
<p><b>MOTOR CONNECTIONS:</b> FOR CCW ROTATION FACING COMM END, MAKE LEADS F1 AND A1 THE SAME POLARITY. FOR CW ROTATION FACING COMM END, MAKE LEADS F1 AND A2 THE SAME POLARITY.</p>	<p><b>GENERATOR CONNECTIONS:</b> FOR CW ROTATION FACING COMM END, F1 POSITIVE WILL MAKE A2 POSITIVE. FOR CCW ROTATION FACING COMM END, F1 POSITIVE WILL MAKE A2 POSITIVE.</p>	
<p>FOR LOW NAMEPLATE EXCITATION VOLTAGE CONNECT SHUNT FIELD LEADS AS INDICATED</p>	 <p style="text-align: center;">(F1,F3) (F2,F4)</p>	
<p><b>MOTOR CONNECTIONS:</b> FOR CCW ROTATION FACING COMM END, MAKE LEADS (F1,F3) AND A1 THE SAME POLARITY. FOR CW ROTATION FACING COMM END, MAKE LEADS (F1,F3) AND A2 THE SAME POLARITY.</p>	<p><b>GENERATOR CONNECTIONS:</b> FOR CW ROTATION FACING COMM END, (F1,F3) POSITIVE WILL MAKE A2 POSITIVE. FOR CCW ROTATION FACING COMM END, (F1,F3) POSITIVE WILL MAKE A1 POSITIVE.</p>	
<p>94-10-12 NO S.O. DC HILL RETRACED</p>	<p>MADE BY N STEWART 75-08-05</p> <p>RE-ISSUED CAD/DC Hill 94-10-12</p>	<p>APPROVALS FILE KC13-1</p> <p>GE MOTORS ERIE</p> <p>DIV OR DEPT LOCATION</p>
36A167960CA501 CONT ON SHEET SH NO.		DISTR TO 49-3131 4487 CAD

ORIGINAL TRACING

C5X.A.36A167960CA501R01