

| | | |
|-----------------------|---|---------------------|
| DATE JULY 11, 2005 | OUTLINE DIMENSIONS 3-PHASE INDUCTION MOTOR | MODEL TYPE: AEGA |
| CATALOG NO. G0/72 | | FRAME NO. A56 |

| | | | | | |
|------|-----|----|----|---------|-----------------------|
| Pole | HP | KW | Hz | VOLT | Syn. Speed R. P. M |
| 2 | 3/4 | | 60 | 230/460 | 3600 |

| | | | | | |
|------|--------|---------------|---------------|------------|-------------|
| Ins. | Rating | Dimensions in | Approx Weight | Bearings | |
| F | CONT. | inch | 18.92 lbs | DE: 6205ZZ | NDE: 6204ZZ |

Totally Enclosed Fan Cooled
Squirrel-Cage

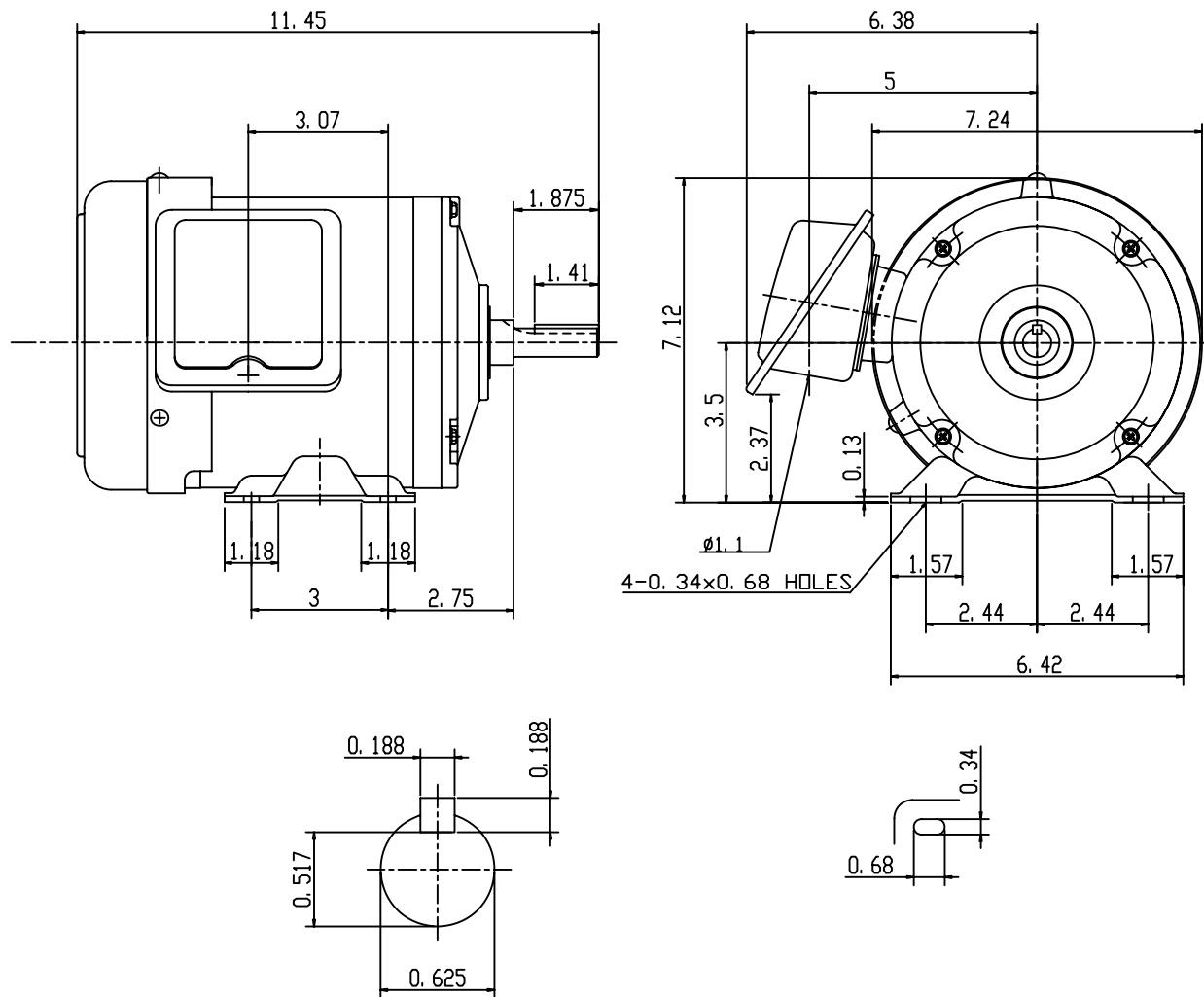

SCALE 4: 1

| | | | | | |
|-------|------------|----------|--|---------|-----------|
| APPD. | W. H. TSAI | 07 21 03 | | DWG NO. | 31049Z105 |
| CHKD. | J. B. CHEN | 07 20 03 | | 2182 | |
| DWN. | Y. Y. CHEN | 07 20 03 | | | |