

Product Information Packet

November 9, 2016

Data shown is for the current revision model #. Ensure your nameplate model # matches.

Model Number:	5KS182SAA200D
Catalog Number:	M9889
Instruction Manual:	GEI-56128
Connection Diagram:	GEM2034E-FIG1
Outline Drawing:	4002B5818PBP5316

Accessory Connection Diagrams			
Bearing Thermocouple:	None	Heater:	None
RTD:	None	Thermistor:	None
Thermostat:	None	Winding Thermocouple:	None
Bearing RTD:	None		

Table of Contents

Specification	01
Performance Characteristics	02
Outline Drawing	03
Connection Drawing(s)	04
Spare parts	05



Marks:

MODEL NUMBER:	5KS182SAA200D	Estimated Weight:	76 Lbs
Outline Drawing:	4002B5818PBP5316	Time Rating:	CONT
Connection Diagram:	GEM2034E-FIG1	Enclosure:	TEFC
Instruction Book:	GEI-56128	Encl Construction:	X\$D
Design Code:	18BD1124AA	Ambient Max(°C):	40
Type:	KS	Alt Ambient Max(°C):	65
Frame:	182TC	Insulation Class:	H
Phases:	3	NEMA Design:	B
Poles:	4	Nominal Efficiency:	89.5 %
Output Power:	3HP 2.2KW	Guaranteed Efficiency:	88.5
RPM:	1765	3/4 Load Efficiency:	89.7
Voltage:	460	KVA Code:	K
Hertz:	60	Max KVAR:	1.3
Amps - FL:	4.0	Power Factor:	78.5
Service Factor:	1.25	Bearing - DE:	6307ZC3
Alt Service Factor:	1.00	Bearing - ODE:	6206ZC3

Enclosure is Totally Enclosed Fan-Cooled

Stamped Nameplate Notes:

SF AMPS 4.9
 STAMP NP249A5564P051 AS BELOW:
 MODEL:5KS182SAA200D S/N: XXX
 CSA CERTIFIED CSA09.2216219 FOR EX NA IIC 200C GC
 CL 1 ZONE2 AEX NA IIC 200C;CL 1 DIV2 GRP ABCD 200C
 IN -25C <= AMB <= 40C, 1.0 SF ON SINE-WAVE PWR
 SURF TEMP 200C AT 1.25SF ON SINE-WAVE PWR
 OR 200 C VT OR 200 C CT OR 200 C CHP PWM CONTROL
 ALTERNATE RATING FOR PWM CONTROL 1.0SF 40C AMB
 VT 0-60 HZ, CT 3-60 HZ , CHP 60-90 HZ.

Additional Information:

4P - T EXTN
 STANDARD FLOOR MOUNT
 C/BOX 30 CU IN-0.75 NPT
 F1 CONDUIT BOX MOUNTING
 "C" FACE AT DE ENDSHIELD
 INPRO SEAL DE ONLY
 OIL RESISTANT SLEEVING ON LEADS

Performance Characteristics

1st Winding 1st Connection

Design: 18BD1124AA

Marks:

LOAD %	125.0	115.0	100.0	75.0	50.0	25.0	0.0
% EFF	88.75	89.14	89.75	89.66	88.36	82.36	0.00
% PF	81.28	80.34	79.73	72.32	60.92	39.89	7.35
AMPS	4.87	4.51	3.92	3.25	2.61	2.14	1.82

TORQ(FL)#FT	8.93	TORQ(LR)%FL	247.75	TORQ(BD)%FL	333.63
AMPS(LR)	26.76	PF AT START	0.52		

This motor is capable of two cold or one hot start with a maximum connected load inertia of 160 Lb-Ft Sq (6.74 Kg-meter Sq)at 100% voltage, where the load torque varies with the square of the speed. Acceleration time with maximum inertia and the above load type is 47 seconds. Safe stall time at 100% voltage is 105 seconds cold, 83 seconds hot. Rotor inertia is 0.28 Lb-Ft Sq (0.01 Kg-meter Sq).

Open Circuit A-C:	0.271	Short Circuit D-C:	0.009
Short Circuit A-C:	0.014	X/R Ratio:	3.257
Stator Slots:	36	Rotor Slots:	28

Speed Torque Current Curve (First Connection, First Speed)

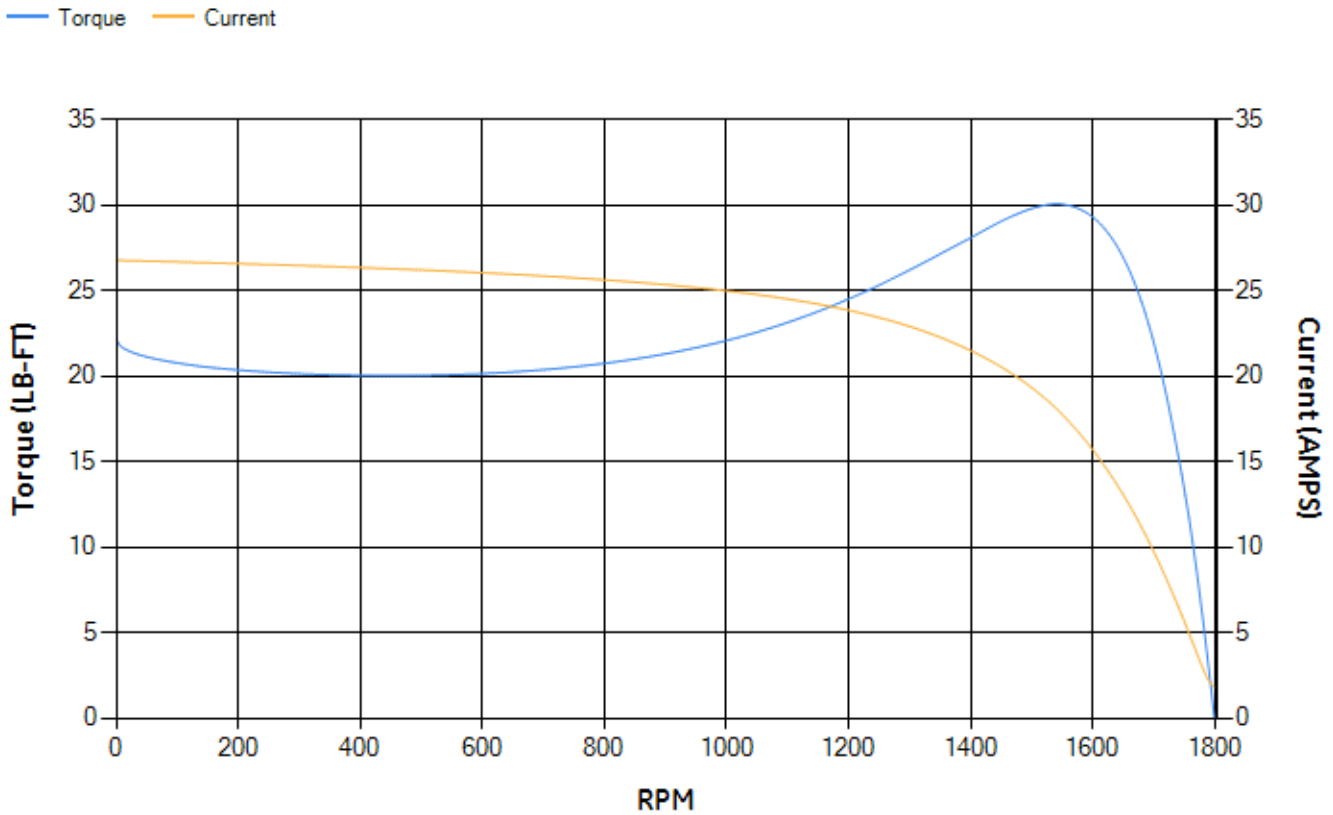

Marks:

- NOTE 1: CONDUIT BOX MAY BE ASSEMBLED WITH ENTRANCE UP, DOWN OR TO EITHER SIDE.
- NOTE 2: F1 ASSEMBLY AS SHOWN. F2 ASSEMBLY CONDUIT BOX ON OPPOSITE SIDE FROM SHOWN LOCATION.
- NOTE 3: MOUNTING SURFACES WILL BE SQUARE AND CONCENTRIC WITH SHAFT WITHIN .004 T. I. R.
- NOTE 4: SHAFT RUNOUT WILL NOT EXCEED .002 T. I. R.
- NOTE 5: ALL DIMENSIONS ARE IN INCHES, BRACKETED DIMENSIONS ARE IN METRIC [MILLIMETERS].

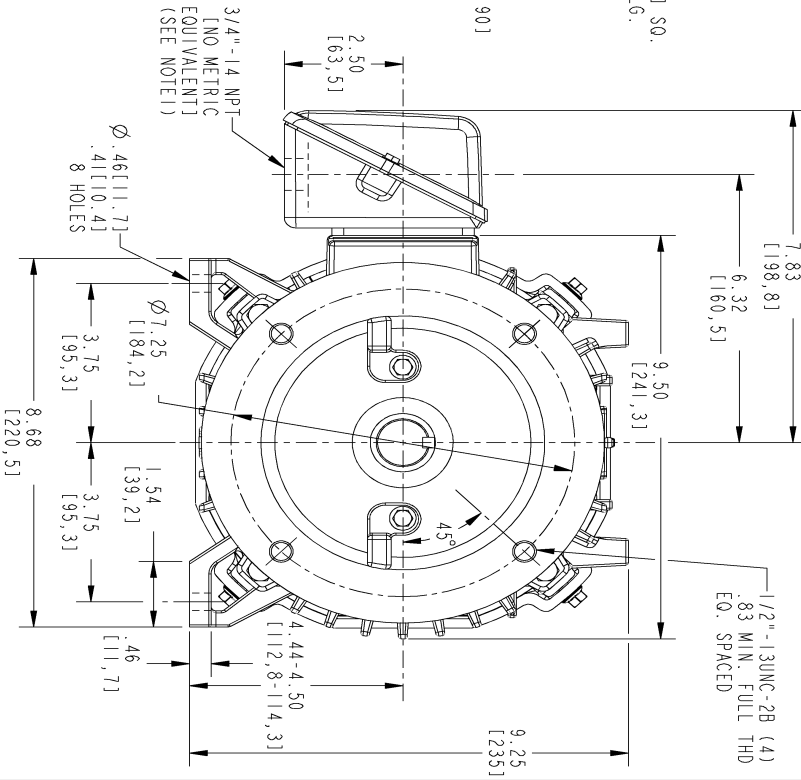
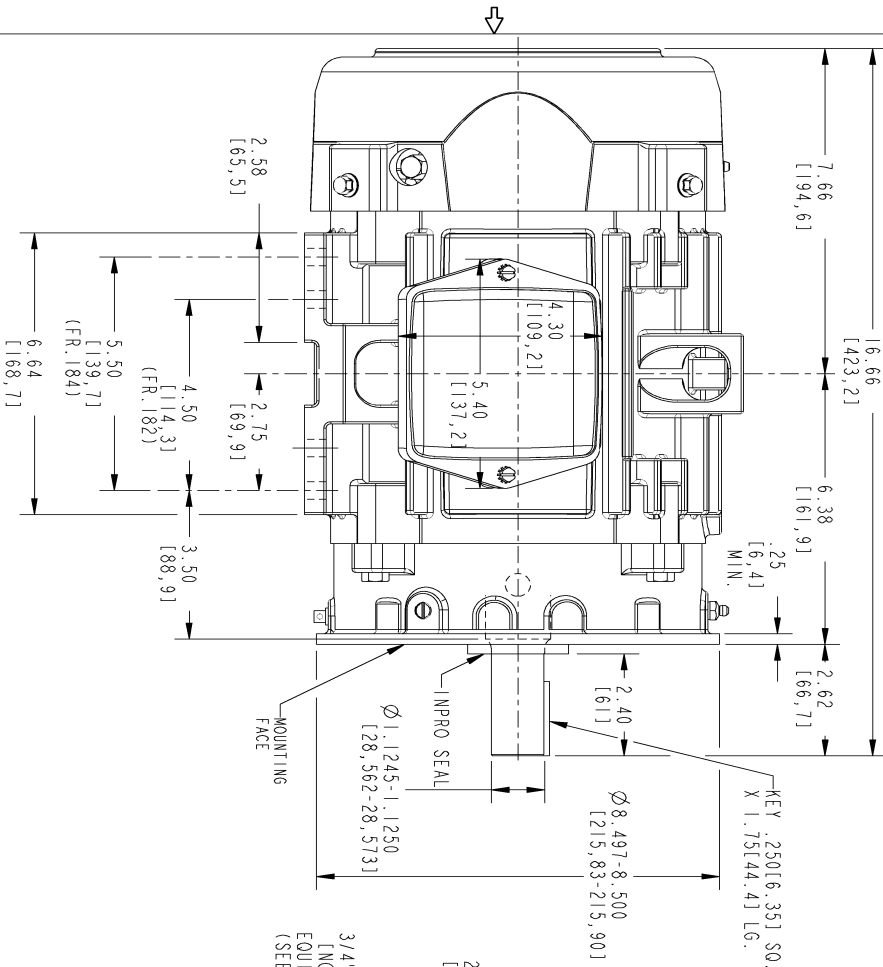

REVISIONS		DATE	APPROVED
REV.	DESCRIPTION	DATE	APPROVED
1	ISAAC #16-0864	08/30/16	VENKAT

SIZE B DRAWING NO. 4002B5818PBP5316 SH 1 REV 1

SIGNATURES	DATE	GE Industrial Systems	GENERAL ELECTRIC COMPANY
DRWN: N PRAJAO	04/23/16		Fort Wayne, Indiana
CHCKD: RAVI KUMAR	04/23/16		
ENGR: N PRAJAO	04/23/16		
APPLIED PRACTICES		SIZE DRAWING B	INDUCTION MOTOR OUTLINE
SCALE: 0.400 REF. NO: 4002B5818PBP5301 SHEET 1 OF 1			'C' FACE AT DE (850° RABBIT), WITH INPROSEAL FWE: KS184TC TFC 'C' FACE 4002B5818PBP5316 REV. 1

DISTRIBUTION: PMP-18K15

Marks:

Connection Diagram
GEM2034E-FIG1



End shield Assembly		
Part Description	DE Side Part#	ODE Side Part#
End Shield	4004D5286PE1	4004D5281SG1
Bearing	235A2601AA01	235A2602AA01
Slinger/Inproseal	316A5384AJ1	149C4399G16

Fan & Fan Cover Assembly	
Part Description	Part#
Fan	346L620AN-G01
Fan Cover	4003C5786PA1

Conduit & Accessories Box Assembly	
Part Description	Part#
Conduit Box	4002B5718PA-G01

Mechanical Accessories	
Part Description	Part#
Brake	
Tachometer	

