

Product Information Packet

November 8, 2016

Data shown is for the current revision model #. Ensure your nameplate model # matches.

Model Number:	5KS213STE205A
Catalog Number:	M7728
Instruction Manual:	GEI-M1031
Connection Diagram:	GEM2034E-FIG210
Outline Drawing:	358B6271AA

Accessory Connection Diagrams

Bearing Thermocouple:	None	Heater:	None
RTD:	None	Thermistor:	None
Thermostat:	None	Winding Thermocouple:	None
Bearing RTD:	None		

Table of Contents

Specification	01
Performance Characteristics	02
Outline Drawing	03
Connection Drawing(s)	04



Marks:

MODEL NUMBER:	5KS213STE205A	Estimated Weight:	202 Lbs
Outline Drawing:	358B6271AA	Time Rating:	CONT
Connection Diagram:	GEM2034E-FIG210	Enclosure:	TEFC
Instruction Book:	GEI-M1031	Encl Construction:	SD
Design Code:	21AD1014A	Ambient Max(°C):	40
Type:	KS	Alt Ambient Max(°C):	--
Frame:	213T	Insulation Class:	F
Phases:	3	NEMA Design:	A
Poles:	4	Nominal Efficiency:	91.7 %
Output Power:	7.5HP 5.6KW	Guaranteed Efficiency:	90.2
RPM:	1765	3/4 Load Efficiency:	92.3
Voltage:	230/460	KVA Code:	J
Hertz:	60	Max KVAR:	2.3
Amps - FL:	18.2/9.1	Power Factor:	84
Service Factor:	1.15	Bearing - DE:	6308ZZC3
Alt Service Factor:	--	Bearing - ODE:	6208ZZC3

Enclosure is Totally Enclosed Fan-Cooled

Stamped Nameplate Notes:

USABLE AT 200V @ 7.5 HP,20.5 AMPS @ 1.0 SF

LRA: 144.6/72.3

50HZ DATA: 5 HP,200/400V, 16.4/8.2 AMPS @ 1.15 SF

50HZ DATA:7.5 HP,200/400V,20.8/10.4 AMPS @ 1.00 SF

GREASE TYPE: SHELL ALVANIA R3 LITHIUM GREASE

Additional Information:

CONDUIT BOX MATERIAL: CAST IRON

SUITABLE FOR USE IN CLASS I DIVISION 2 LOCATIONS

CLASS I DIVISION 2 GROUPS A,B,C,D T3C

CLASS I ZONE 2 IIC T3C

Performance Characteristics

1st Winding 1st Connection

Design: 21AD1014A

Marks:

LOAD %	125.0	115.0	100.0	75.0	50.0	25.0	0.0
% EFF	90.57	91.06	91.87	92.27	91.93	88.43	0.00
% PF	85.23	84.87	83.84	80.09	71.26	50.12	5.98
AMPS	11.37	10.45	9.11	7.12	5.36	3.96	3.24

TORQ(FL)#FT	22.32	TORQ(LR)%FL	274.65	TORQ(BD)%FL	309.86
AMPS(LR)	70.31	PF AT START	0.42		

This motor is capable of two cold or one hot start with a maximum connected load inertia of 287 Lb-Ft Sq (12.08 Kg-meter Sq)at 100% voltage, where the load torque varies with the square of the speed. Acceleration time with maximum inertia and the above load type is 35 seconds. Safe stall time at 100% voltage is 91 seconds cold, 57 seconds hot. Rotor inertia is 0.94 Lb-Ft Sq (0.04 Kg-meter Sq).

Open Circuit A-C:	0.371	Short Circuit D-C:	0.011
Short Circuit A-C:	0.015	X/R Ratio:	4.127
Stator Slots:	48	Rotor Slots:	40

Speed Torque Current Curve (First Connection, First Speed)

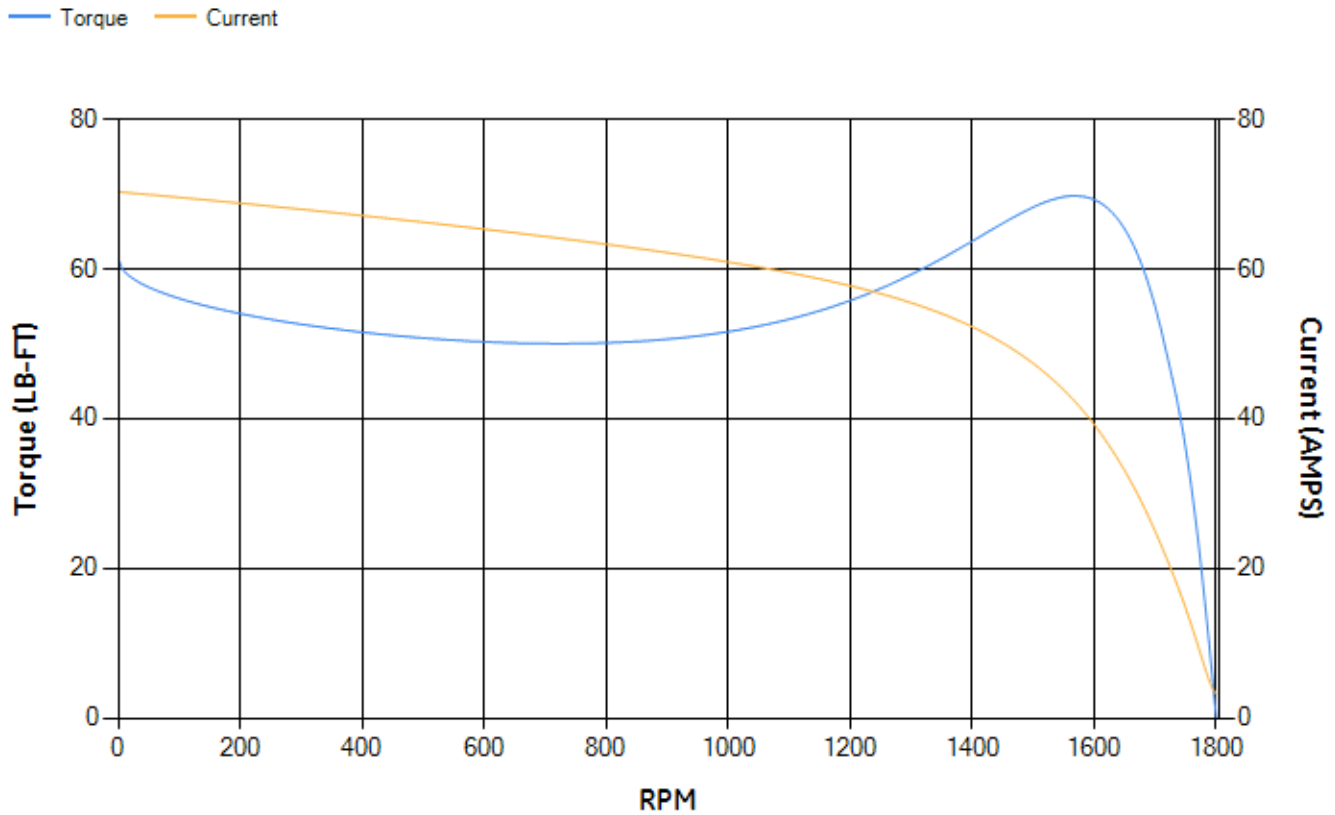

NAME:501291659 OBJECT:358B6271AA DATE:05-Dec-07 10:08:54

Marks:

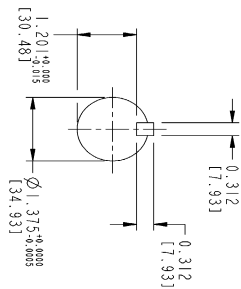
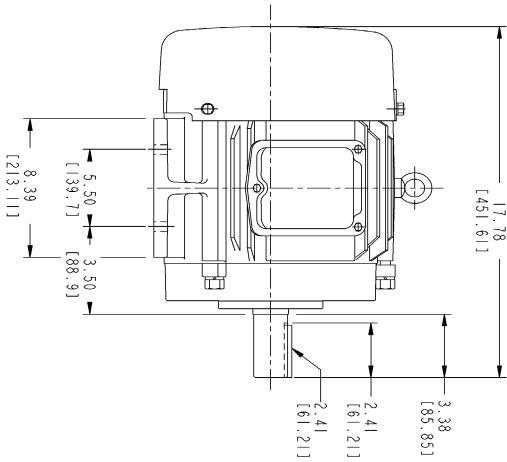
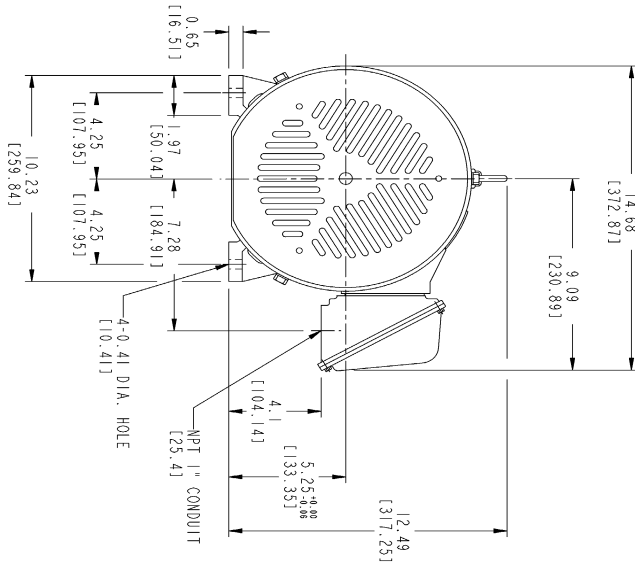

NOTES :

1. DIMENSIONS ARE IN INCHES.
2. F-1 ASM AS SHOWN.
3. F-2 ASM - HAS CONDUIT BOX ON OPPOSITE SIDE.
4. BRACKETED DIMENSIONS ARE METRIC (MILLIMETERS)
5. ICA11, IP94, MB34 APPLY

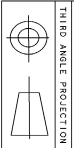

THIRD ANGLE PROJECTION

Part must conform to SI 900000 Sect. 4, Toxicity Procedure

REV.	DESCRIPTION	DATE	APPROVED

358B6271AA 0 1

FOR ADDITIONAL INFO REFER TO:		SIGNATURES		DATE	
REFLECTED DIMENSIONS	DETAIL				
UNREFLECTED DIMENSIONS	SOUMITRA				
TOLERANCE ON DIMENSIONS	SAMU				
± P/L DECIMALS	R. KOHNE				
± P/L DECIMALS					
± ANGLES					
± FRACTIONS					
± FINISH					
MATERIAL	SOUD MODEL NAME				

GENERAL ELECTRIC COMPANY

OUTLINE

FTD - 23T TERC GE MARK
66.7 CU IN CONDUIT BOX

358B6271AA 0

SCALE: C SHEET 1 OF 1

Marks:

Connection Diagram
GEM2034E-FIG210

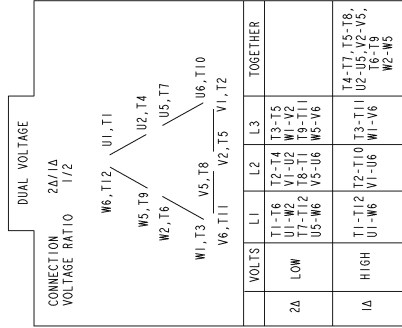

NAME:501452353 OBJECT:GEM2034E-FIG210 DATE:25-Feb-08 14:03:35

