

TYPE	OUTPUT		POLE	TIME RATING	VOLTAGE V	Hz	SYN.SPEED R.P.M
	HP.	KW.					
AEHE	800	597	8	CONT.	460	60	900

TOTALLY ENCLOSED FAN-COOLED TYPE, SQUIRREL-CAGE ROTOR

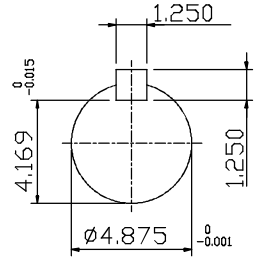
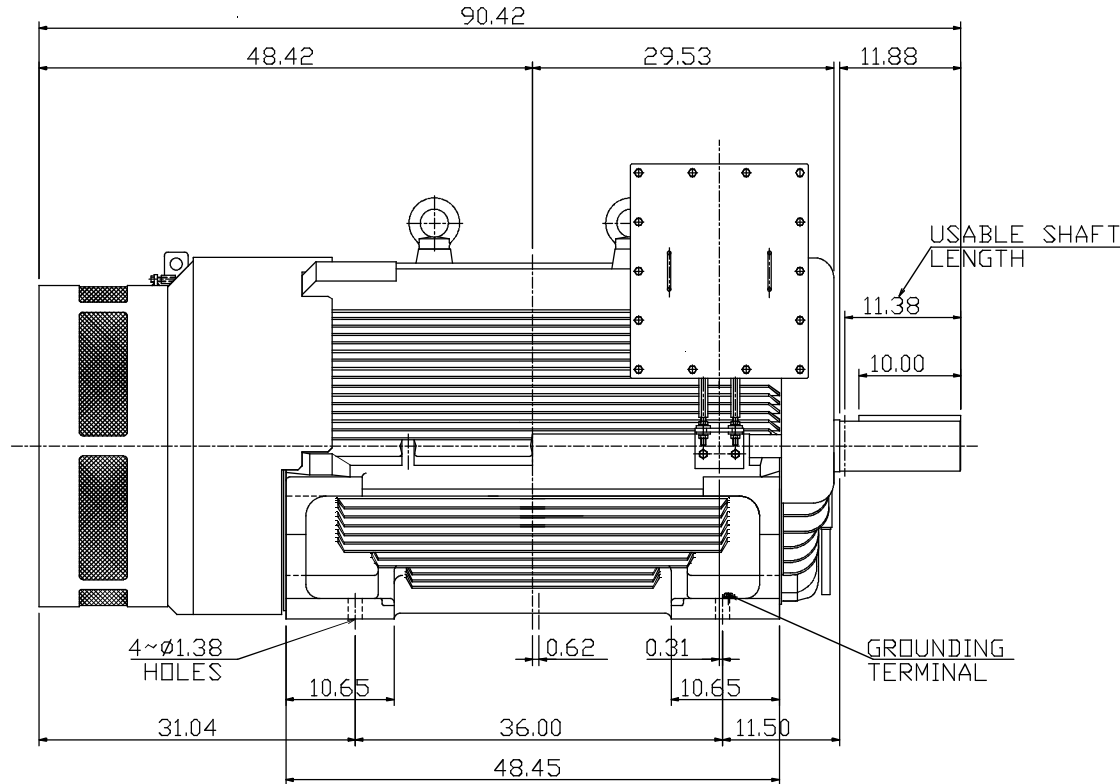
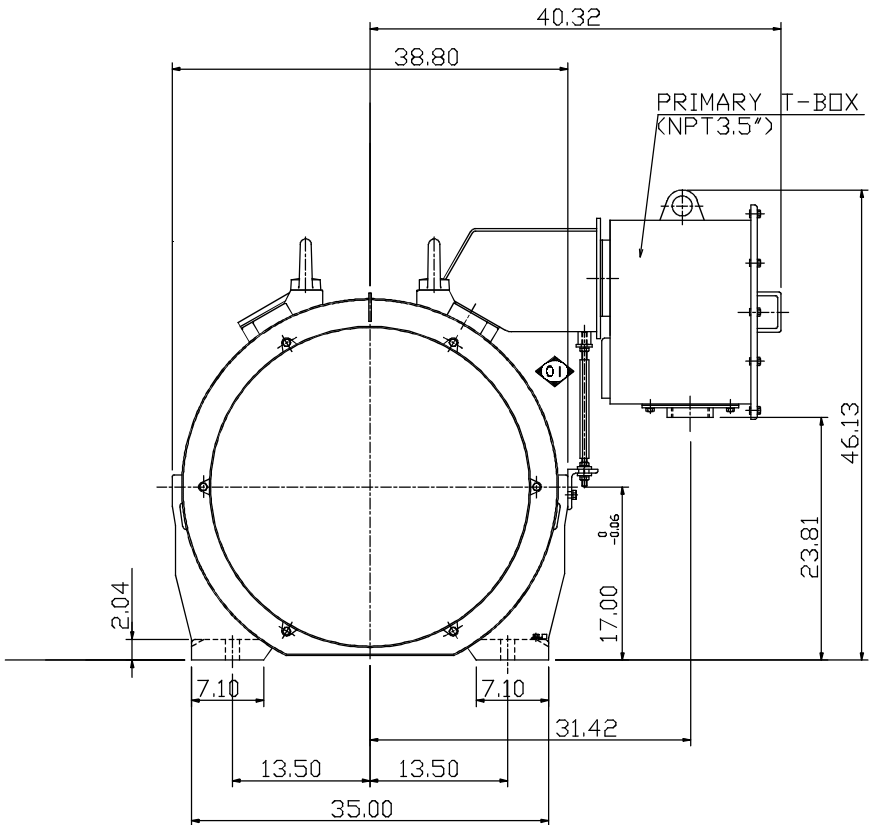

SHAFT END (ENLARGED VIEW)

- NOTE:
1. DIMENSIONS IN INCH
  2. FRAME NO. 6808C
  3. F CLASS INSULATION, S.F.115
  4. FOR BELT DRIVE APPLICATIONS
  5. ENCLOSURE: IP55
  6. BEARING SIZE: DRIVE-END NU326  
OPP. DRIVE-END 6322
  7. MOTOR APPROX. WEIGHT: 8850 LBS

DATE	OUTLINE DIMENSIONS
CATALOG # E8008R	3-PHASE INDUCTION MOTOR

DWN.	Y.DU	AUG-29-2011
CHKD.	H.HUANG	AUG-29-2011
APPD.	B.LIN	AUG-29-2011



DWG NO. REV: 01  
4A040G955