

TYPE	OUTPUT		POLE	TIME RATING	VOLTAGE V	Hz	SYN.SPEED R.P.M
	HP.	KW.					
AEHH8N	350	261	6	CONT.	460	60	1200

TOTALLY ENCLOSED FAN-COOLED TYPE, SQUIRREL-CAGE ROTOR

PRIMARY T-BOX
(NPT4")

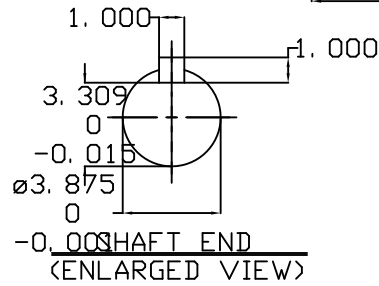
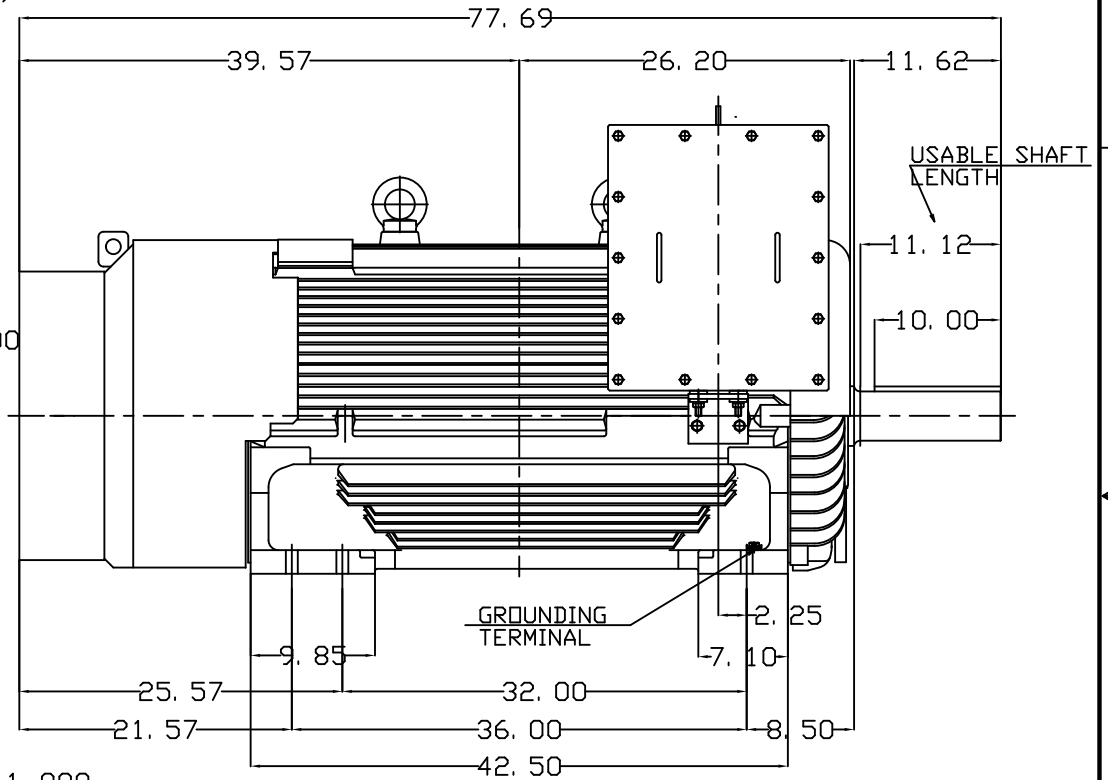
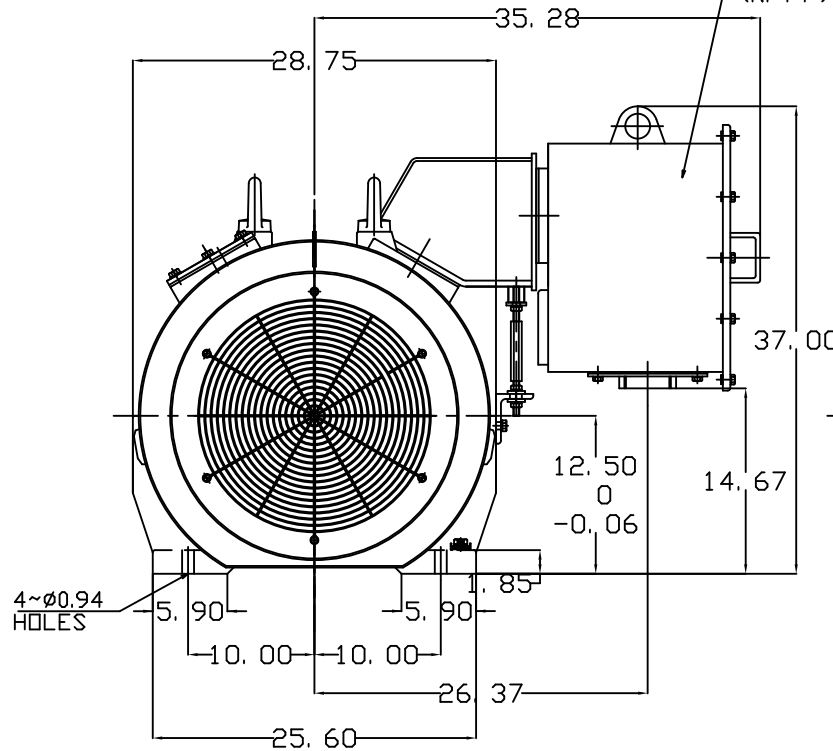

NOTE:

1. DIMENSIONS IN inch
2. FRAME NO. 5011C(5010C)
3. F CLASS INSULATION, S.F.1.15
4. FOR BELT DRIVE APPLICATION
5. ENCLOSURE: IP55
6. BEARING SIZE: DRIVE-END NU324
OPP. DRIVE-END 6320
7. MOTOR APPROX. WEIGHT: 5565 lb

DATE	OUTLINE DIMENSIONS	
CATALOG # EP3506R	3-PHASE INDUCTION MOTOR	
DWN. Y.DU MAR-20-2014	TECO Westinghouse	DWG NO. REV:00
CHKD. W.CHENG MAR-29-2014		4B040C015
APPD. C.SHIH MAR-29-2014		