

6 | 5 | 4 | 3 | 2 | 1

TYPE	OUTPUT		POLE	TIME RATING	VOLTAGE V	Hz	SYN.SPEED R.P.M
	HP.	KW.					
AEHE	700	522	4	CONT.	460	60	1800

TOTALLY ENCLOSED FAN-COOLED TYPE, SQUIRREL-CAGE ROTOR

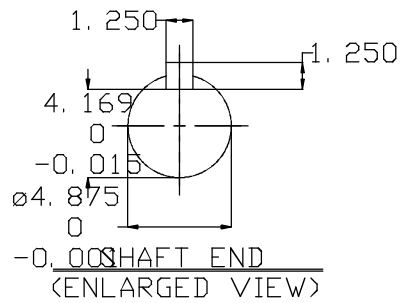
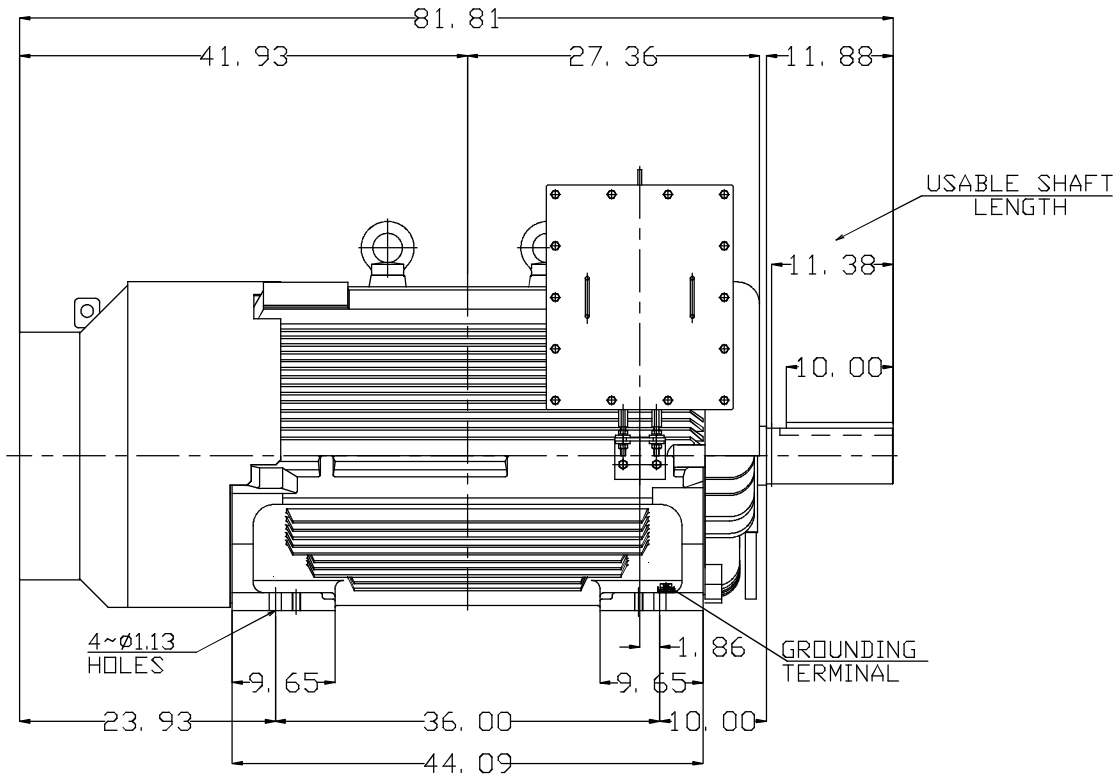
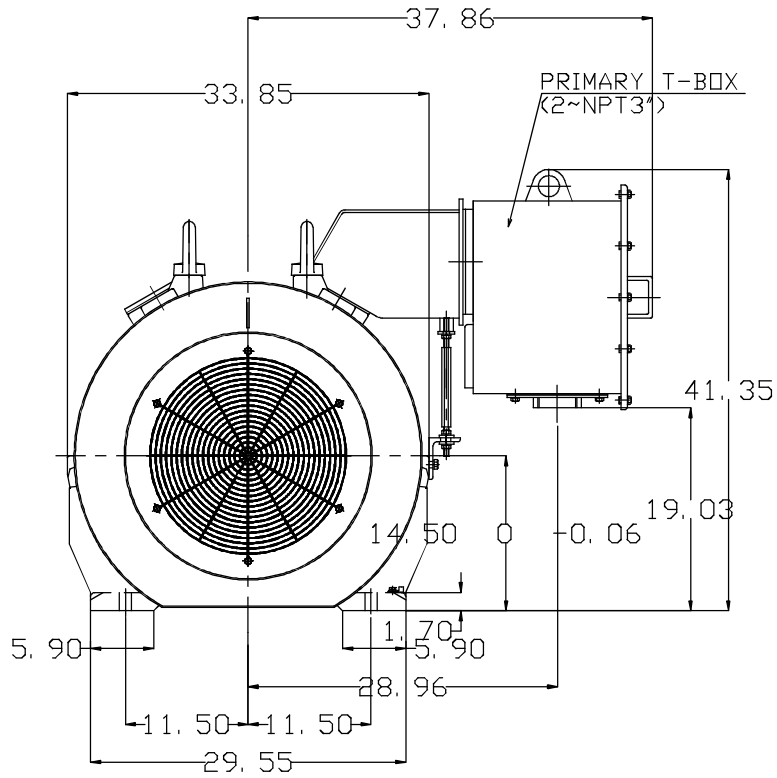

- NOTE:
1. DIMENSIONS IN inch
 2. FRAME NO. 5810B
 3. F CLASS INSULATION, S.F.1.15
 4. FOR DIRECT FLEXIBLE COUPLING
 5. ENCLOSURE: IP55
 6. BEARING SIZE: DRIVE-END 6326
OPP. DRIVE-END 6322
 7. MOTOR APPROX. WEIGHT: 6800 lb

DATE	OUTLINE DIMENSIONS	
CATALOG # E7004	3-PHASE INDUCTION MOTOR	
DWN. Y.DU MAR-24-2014	TECO Westinghouse	DWG NO. REV:00
CHKD. W.CHENG MAR-29-2014		4B040C043
APPD. C.SHIH MAR-29-2014		

6 | 5 | 4 | 3 | 2 | 1