

Product Information Packet

November 8, 2016

Data shown is for the current revision model #. Ensure your nameplate model # matches.

Model Number:	5KS184XAA208D2
Catalog Number:	M9423
Instruction Manual:	GEI-56128
Connection Diagram:	GEM2034E-FIG1
Outline Drawing:	4002B5818PAP5311

Accessory Connection Diagrams

Bearing Thermocouple:	None	Heater:	None
RTD:	None	Thermistor:	None
Thermostat:	None	Winding Thermocouple:	None
Bearing RTD:	None		

Table of Contents

Specification	01
Performance Characteristics	02
Outline Drawing	03
Connection Drawing(s)	04
Spare parts	05



Marks:

MODEL NUMBER:	5KS184XAA208D2	Estimated Weight:	101 Lbs
Outline Drawing:	4002B5818PAP5311	Time Rating:	CONT
Connection Diagram:	GEM2034E-FIG1	Enclosure:	TEFC
Instruction Book:	GEI-56128	Encl Construction:	841
Design Code:	18BD1001A	Ambient Max(°C):	40
Type:	KS	Alt Ambient Max(°C):	--
Frame:	184T	Insulation Class:	H
Phases:	3	NEMA Design:	B
Poles:	4	Nominal Efficiency:	89.5 %
Output Power:	5HP 3.7KW	Guaranteed Efficiency:	88.5
RPM:	1755	3/4 Load Efficiency:	90.4
Voltage:	460	KVA Code:	J
Hertz:	60	Max KVAR:	2.0
Amps - FL:	6.6	Power Factor:	79.5
Service Factor:	1.15	Bearing - DE:	6206ZC3
Alt Service Factor:	--	Bearing - ODE:	6206ZC3

Enclosure is Totally Enclosed Fan-Cooled

Stamped Nameplate Notes:

IEEE-STD-841-2009
 DE BRG 30BC02JP30 ODE BRG 30BC02JP30
 STAMP NP249A5564P051 AS BELOW:
 MODEL:5KS184XAA208D2 S/N: XXX
 CSA CERTIFIED CSA09.2216219 FOR EX NA IIC 200 C GC
 CL1ZONE2 AEXNAIIC 200 C; CL1DIV2 GRP ABCD 200 C
 IN -25C <= AMB <= 40C, 1.0 SF ON SINE-WAVE PWR
 SURF TEMP 200 C AT 1.15 SF ON SINE-WAVE PWR
 OR 200 C VT OR 215 C CT OR 200 C CHP PWM CONTROL
 ALTERNATE RATING FOR PWM CONTROL 1.0 SF 40 C AMB
 VT 0-60 HZ, CT 3-60 HZ, CHP 60-90 HZ.

Additional Information:

4P - T EXTN
 STANDARD FLOOR MOUNT
 C/BOX 55 CU IN-1.00 NPT
 F1 CONDUIT BOX MOUNTING
 PAINTED FRAME ID & SHAFT,
 FAN COVER INSIDE & ODE E/S OUTSIDE
 ROUTINE AND 5 POINT VIBRATION TESTS INCL IN C/BOX
 INPRO SEAL BOTH ENDS
 GROUND SCREW ON FRAME
 SHAFT RUNOUT LIMIT .001" TIR
 COPPER WASHER UNDER HEADS OF BEARING CAP BOLTS
 APPLY TITE-SEAL (A50CD427A) ON BEARING CAP SCREWS, RABBETS,
 AND PLUG THREADS
 OIL RESISTANT SLEEVING ON LEADS

Performance Characteristics

1st Winding 1st Connection

Design: 18BD1001A

Marks:

LOAD %	125.0	115.0	100.0	75.0	50.0	25.0	0.0
% EFF	88.12	88.78	89.81	90.44	90.1	85.98	0.00
% PF	81.6	80.98	80.8	74.23	63.37	41.66	5.79
AMPS	8.14	7.49	6.45	5.23	4.1	3.27	2.74

TORQ(FL)#FT	14.97	TORQ(LR)%FL	228.66	TORQ(BD)%FL	298.67
AMPS(LR)	41.06	PF AT START	0.51		

This motor is capable of two cold or one hot start with a maximum connected load inertia of 183 Lb-Ft Sq (7.7 Kg-meter Sq)at 100% voltage, where the load torque varies with the square of the speed. Acceleration time with maximum inertia and the above load type is 36 seconds. Safe stall time at 100% voltage is 79 seconds cold, 51 seconds hot. Rotor inertia is 0.35 Lb-Ft Sq (0.01 Kg-meter Sq).

Open Circuit A-C:	0.237	Short Circuit D-C:	0.008
Short Circuit A-C:	0.012	X/R Ratio:	3.151
Stator Slots:	36	Rotor Slots:	28

Speed Torque Current Curve (First Connection, First Speed)

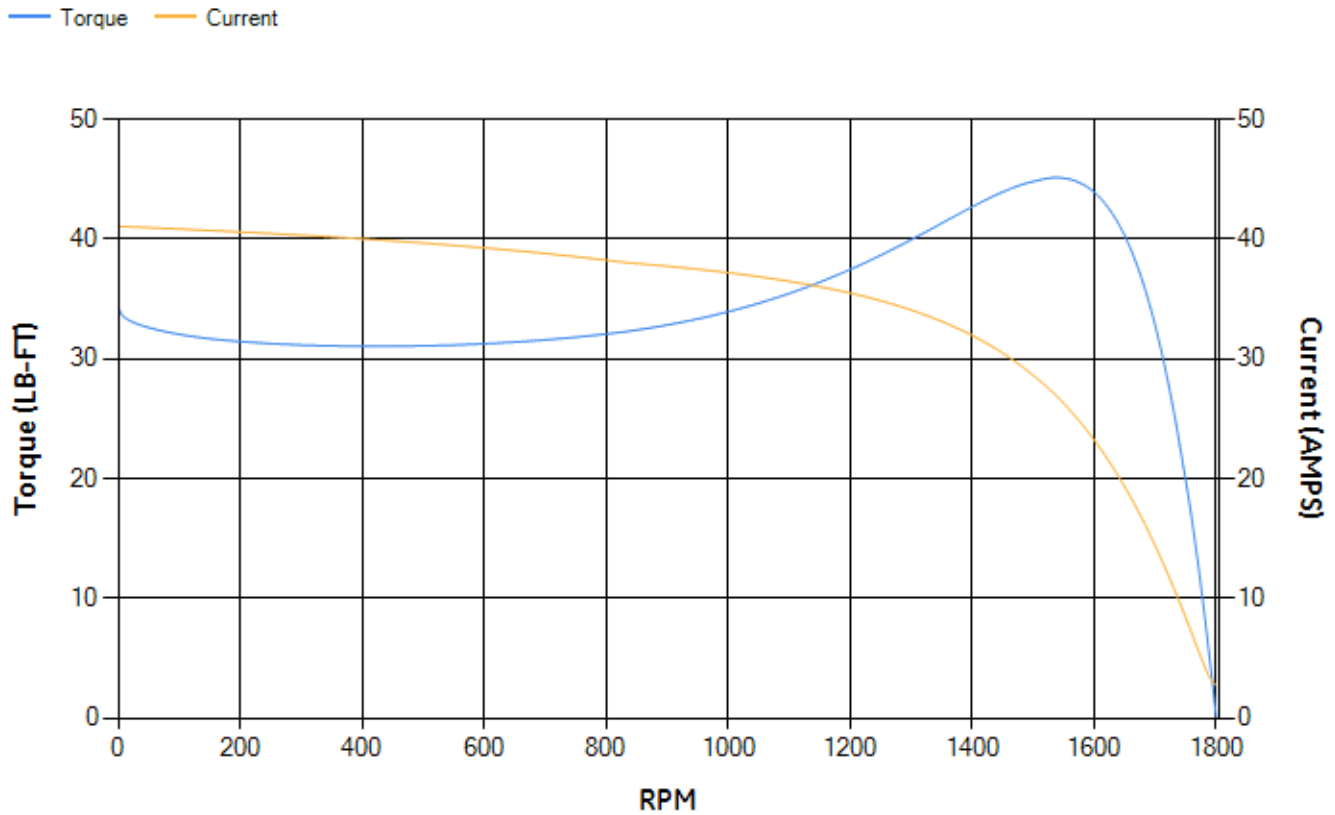

Marks:

NOTE 1: CONDUIT BOX MAY BE ASSEMBLED WITH ENTRANCE UP, DOWN OR TO EITHER SIDE.
 NOTE 2: F1 ASSEMBLY AS SHOWN. F2 ASSEMBLY CONDUIT BOX ON OPPOSITE SIDE FROM SHOWN LOCATION.
 NOTE 3: SHAFT RUNOUT WILL NOT EXCEED .001 T.I.R.
 NOTE 4: ALL DIMENSIONS ARE IN INCHES, BRACKETED DIMENSIONS ARE IN METRIC (MILLIMETERS).

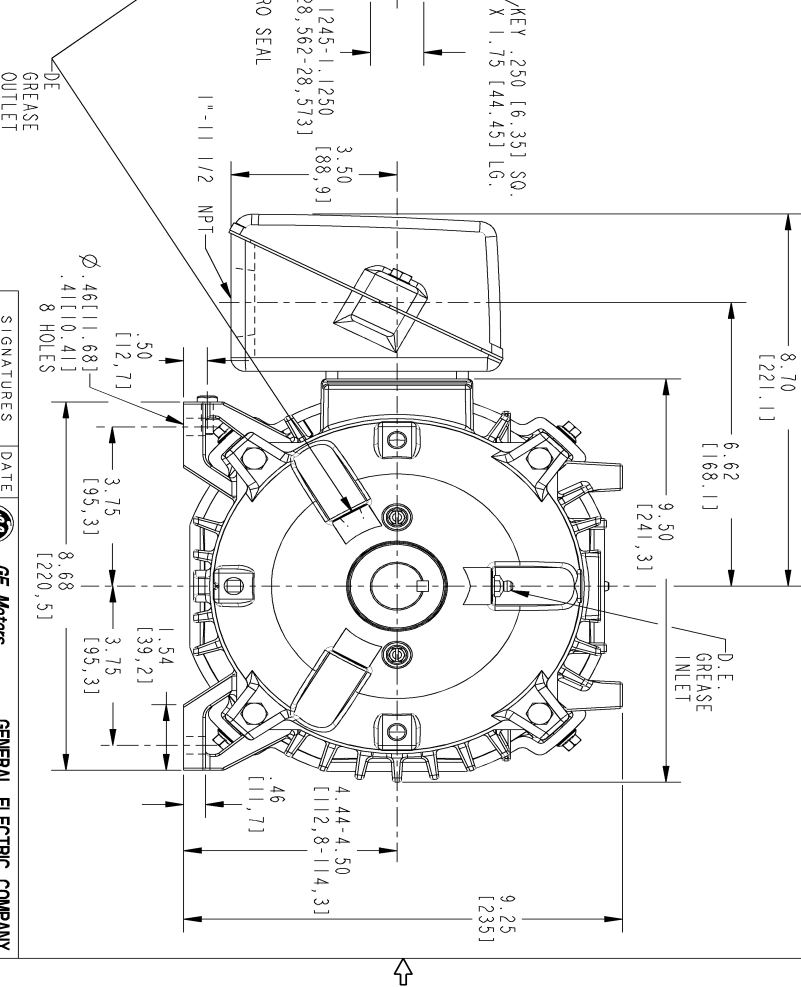
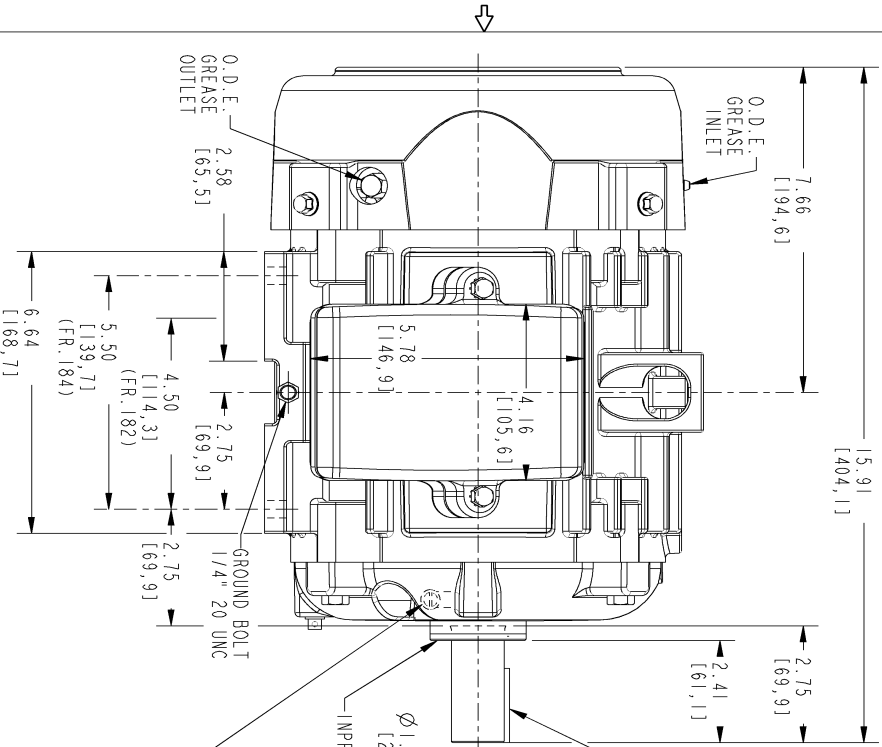

SIZE DRAWING NO. B

4002B5818PAP5311 2

REV SHEET 1

REVISIONS			
REV.	DESCRIPTION	DATE	APPROVED
1	ISAAC #15-0731	07/17/15	KARTHIK
2	ISAAC #16-0079	01/28/16	SRAVANTHI D

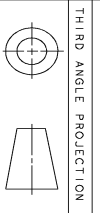

SIGNATURES		DATE	
MODEL	TEJASVI	06/04/15	
DETAIL	TEJASVI	06/04/15	
CHECKED	VENKAT	06/04/15	
ENGR	VENKAT	06/04/15	
QC			
QUALITY	TEJASVI	06/04/15	
ISSUED			
SHEET 1 OF 1			

GE Motors GENERAL ELECTRIC COMPANY
INDUCTION MOTOR OUTLINE
 STANDARD CONSTRUCTION FOR IEEE-841 SPEC
 FR182/184 T TEFC
4002B5818PAP5311 2

SCALE: 0.400 REF. No.: 4002B5818PAP5301

Marks:

Connection Diagram
GEM2034E-FIG1



End shield Assembly		
Part Description	DE Side Part#	ODE Side Part#
End Shield	4004D5281PB1	4004D5281SG1
Bearing	235A2602AA01	235A2602AA01
Slinger/Inproseal	4002B5914AF2	4002B5914AG2

Fan & Fan Cover Assembly	
Part Description	Part#
Fan	4001A5914AM-G01
Fan Cover	4003C5786PA1

Conduit & Accessories Box Assembly	
Part Description	Part#
Conduit Box	4002B5721PA-G01

Mechanical Accessories	
Part Description	Part#
Brake	
Tachometer	

