

Product Information Packet

November 9, 2016

Data shown is for the current revision model #. Ensure your nameplate model # matches.

Model Number:	5KS254SAA300D
Catalog Number:	M9954
Instruction Manual:	GEI-56128
Connection Diagram:	GEM2034E-FIG7
Outline Drawing:	4002B5825PBP5316

Accessory Connection Diagrams			
Bearing Thermocouple:	None	Heater:	None
RTD:	None	Thermistor:	None
Thermostat:	None	Winding Thermocouple:	None
Bearing RTD:	None		

Table of Contents

Specification	01
Performance Characteristics	02
Outline Drawing	03
Connection Drawing(s)	04
Spare parts	05



Marks:

MODEL NUMBER:	5KS254SAA300D	Estimated Weight:	315 Lbs
Outline Drawing:	4002B5825PBP5316	Time Rating:	CONT
Connection Diagram:	GEM2034E-FIG7	Enclosure:	TEFC
Instruction Book:	GEI-56128	Encl Construction:	X\$D
Design Code:	25BD3062A	Ambient Max(°C):	40
Type:	KS	Alt Ambient Max(°C):	65
Frame:	254TC	Insulation Class:	H
Phases:	3	NEMA Design:	B
Poles:	6	Nominal Efficiency:	91 %
Output Power:	7.5HP 5.6KW	Guaranteed Efficiency:	90.2
RPM:	1175	3/4 Load Efficiency:	91.6
Voltage:	460	KVA Code:	H
Hertz:	60	Max KVAR:	3.1
Amps - FL:	9.7	Power Factor:	79.5
Service Factor:	1.25	Bearing - DE:	6310ZC3
Alt Service Factor:	1.00	Bearing - ODE:	6309ZC3

Enclosure is Totally Enclosed Fan-Cooled

Stamped Nameplate Notes:

SF AMPS 11.9
 STAMP NP249A5564P051 AS BELOW:
 MODEL:5KS254SAA300D S/N: XXX
 CSA CERTIFIED CSA09.2216219 FOR EX NA IIC 200C GC
 CL 1 ZONE2 AEX NA IIC 200C;CL 1 DIV2 GRP ABCD 200C
 IN -25C <= AMB <= 40C, 1.0 SF ON SINE-WAVE PWR
 SURF TEMP 200C AT 1.25SF ON SINE-WAVE PWR
 OR 200 C VT OR 200 C CT OR 200 C CHP PWM CONTROL
 ALTERNATE RATING FOR PWM CONTROL 1.0SF 40C AMB
 VT 0-60 HZ, CT 3-60 HZ , CHP 60-90 HZ.

Additional Information:

6P - T EXTN
 STANDARD FLOOR MOUNT
 C/BOX 137 CU IN-1.25 NPT
 F1 CONDUIT BOX MOUNTING
 "C" FACE AT DE ENDSHIELD
 INPRO SEAL DE ONLY
 OIL RESISTANT SLEEVING ON LEADS

Performance Characteristics

1st Winding 1st Connection

Design: 25BD3062A

Marks:

LOAD %	125.0	115.0	100.0	75.0	50.0	25.0	0.0
% EFF	90.17	90.62	91.38	91.65	91.06	86.89	0.00
% PF	81.86	81.11	79.36	73.97	62.99	41.32	5.27
AMPS	11.89	10.98	9.68	7.77	6.12	4.89	4.29

TORQ(FL)#FT	33.51	TORQ(LR)%FL	188.29	TORQ(BD)%FL	270.19
AMPS(LR)	59.47	PF AT START	0.39		

This motor is capable of two cold or one hot start with a maximum connected load inertia of 958 Lb-Ft Sq (40.33 Kg-meter Sq)at 100% voltage, where the load torque varies with the square of the speed. Acceleration time with maximum inertia and the above load type is 64 seconds. Safe stall time at 100% voltage is 142 seconds cold, 108 seconds hot. Rotor inertia is 1.9 Lb-Ft Sq (0.08 Kg-meter Sq).

Open Circuit A-C:	0.273	Short Circuit D-C:	0.012
Short Circuit A-C:	0.017	X/R Ratio:	4.532
Stator Slots:	54	Rotor Slots:	42

Speed Torque Current Curve (First Connection, First Speed)

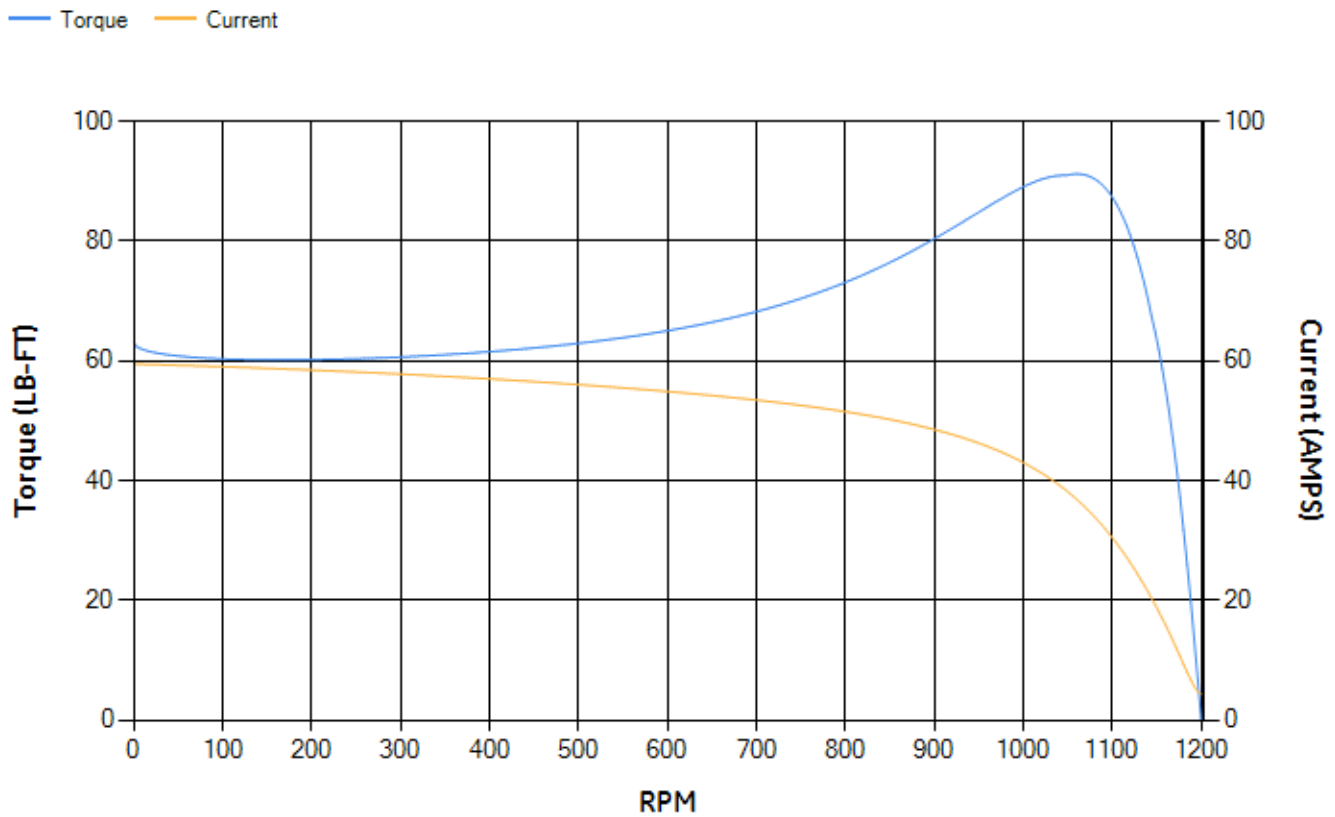

Marks:

- NOTE 1: CONDUIT BOX MAY BE ASSEMBLED WITH ENTRANCE UP, DOWN OR TO EITHER SIDE.
 NOTE 2: F1 ASSEMBLY AS SHOWN. F2 ASSEMBLY CONDUIT BOX ON OPPOSITE SIDE FROM SHOWN LOCATION.
 NOTE 3: MOUNTING SURFACES WILL BE SQUARE AND CONCENTRIC WITH SHAFT WITHIN .004 T.I.R.
 NOTE 4: SHAFT RUNOUT WILL NOT EXCEED .002 T.I.R.
 NOTE 5: ALL DIMENSIONS ARE IN INCHES, BRACKETED DIMENSIONS ARE IN METRIC (MILLIMETERS)

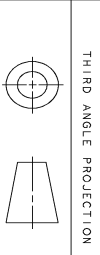
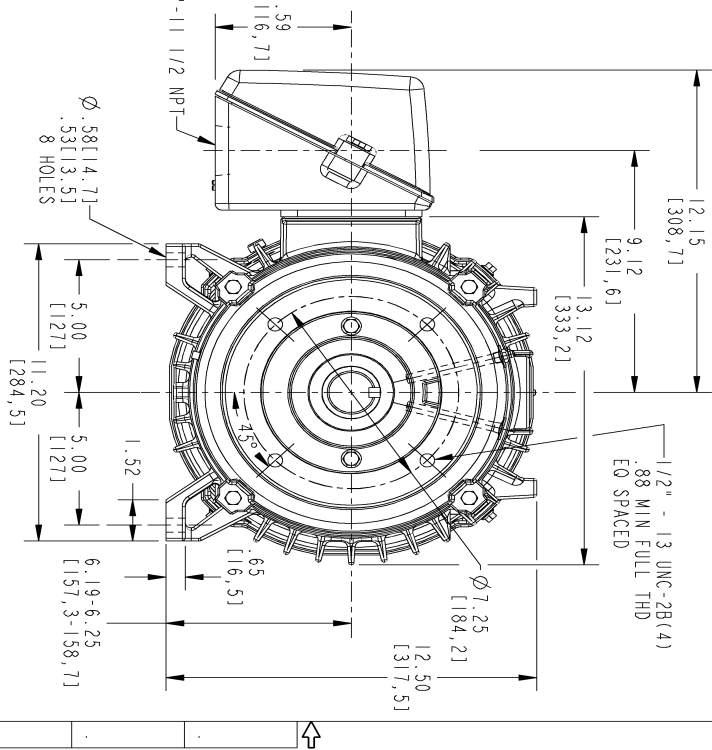
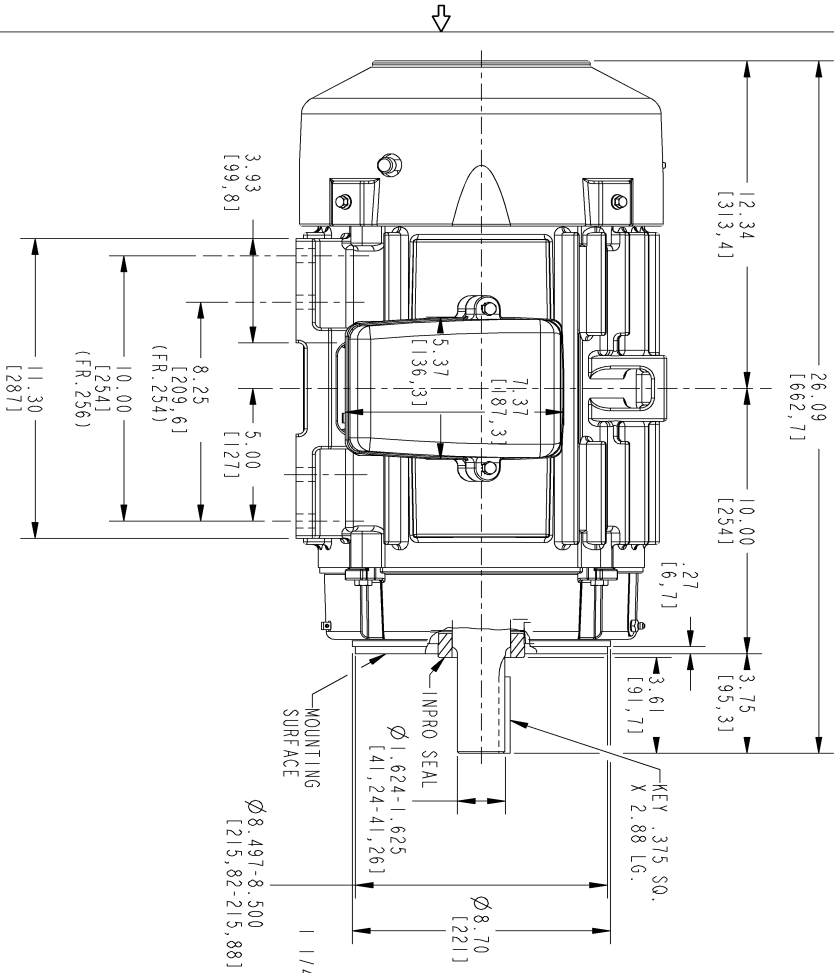

SIZE B DRAWING NO. 4002B5825PBP5316

SH 1 REV 1

REVISIONS			
REV.	DESCRIPTION	DATE	APPROVED
1	ISAAC #13-0151	HARI 02/19/13	MANCHI

SIGNATURES	DATE
DRWN: SHIVA KUMAR	03/21/04
CHCKD: SHIVA KUMAR	03/21/04
ENGR: SHIVA KUMAR	03/21/04
ISSD: SHIVA SHANKAR	03/21/04

GE Industrial Systems
GENERAL ELECTRIC COMPANY
 Fort Wayne, Indiana

"C" FACE AT DRIVE END WITH INPRO SEAL
FMR K5254TC TEFC "C" FACE (350° RABBIT)
 SIZE DRAWING: **4002B5825PBP5316**
 SCALE: 0.250 REF. NO.: 4002B5825PBP301 SHEET 1 OF 1

DISTRIBUTION: PMP-18K15

Marks:

Connection Diagram
GEM2034E-FIG7

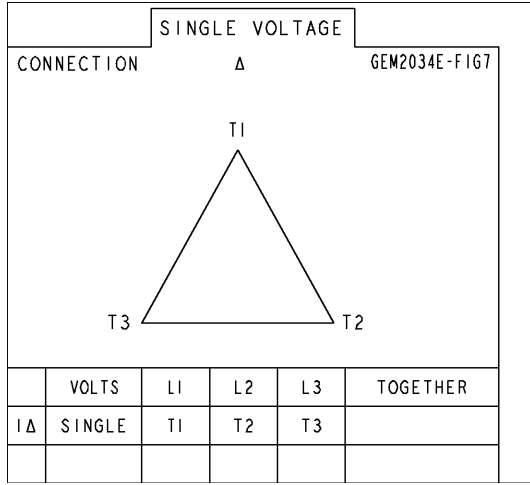

End shield Assembly		
Part Description	DE Side Part#	ODE Side Part#
End Shield	128D6106PP1	4004D5283SE1
Bearing	235A2608AA01	235A2607AA01
Slinger/Inproseal	235A4575GC20	149C4399G02

Fan & Fan Cover Assembly	
Part Description	Part#
Fan	159C6800G01
Fan Cover	4003C5788PA1

Conduit & Accessories Box Assembly	
Part Description	Part#
Conduit Box	4002B5728PA-G04

Mechanical Accessories	
Part Description	Part#
Brake	
Tachometer	