

Product Information Packet

November 8, 2016

Data shown is for the current revision model #. Ensure your nameplate model # matches.

Model Number:	5KS145SAA408C
Catalog Number:	M9170
Instruction Manual:	GEI-56128
Connection Diagram:	GEM2034E-FIG1
Outline Drawing:	4002B5814PAP5201

Accessory Connection Diagrams

Bearing Thermocouple:	None	Heater:	None
RTD:	None	Thermistor:	None
Thermostat:	None	Winding Thermocouple:	None
Bearing RTD:	None		

Table of Contents

Specification	01
Performance Characteristics	02
Outline Drawing	03
Connection Drawing(s)	04
Spare parts	05



Marks:

MODEL NUMBER:	5KS145SAA408C	Estimated Weight:	50 Lbs
Outline Drawing:	4002B5814PAP5201	Time Rating:	CONT
Connection Diagram:	GEM2034E-FIG1	Enclosure:	TEFC
Instruction Book:	GEI-56128	Encl Construction:	X\$D
Design Code:	14BD4008AA	Ambient Max(°C):	40
Type:	KS	Alt Ambient Max(°C):	50
Frame:	145T	Insulation Class:	H
Phases:	3	NEMA Design:	--
Poles:	8	Nominal Efficiency:	70 %
Output Power:	0.75HP 0.6KW	Guaranteed Efficiency:	68.0
RPM:	845	3/4 Load Efficiency:	74.1
Voltage:	460	KVA Code:	P
Hertz:	60	Max KVAR:	0.9
Amps - FL:	1.8	Power Factor:	55.0
Service Factor:	1.15	Bearing - DE:	6205ZC3
Alt Service Factor:	1.00	Bearing - ODE:	6205ZC3

Enclosure is Totally Enclosed Fan-Cooled

Stamped Nameplate Notes:

STAMP NP249A5564P051 AS BELOW:
 MODEL:5KS145SAA408C S/N: XXX
 CSA CERTIFIED CSA09.2216219 FOR EX NA IIC 200C GC
 CL 1 ZONE2 AEX NA IIC 200C;CL 1 DIV2 GRP ABCD 200C
 IN -40C <= AMB <= 40C, 1.0 SF ON SINE-WAVE PWR
 SURF TEMP 200C AT 1.15SF ON SINE-WAVE PWR
 OR 200 C VT OR 200 C CT OR 200 C CHP PWM CONTROL
 ALTERNATE RATING FOR PWM CONTROL 1.0SF 40C AMB
 VT 0-60 HZ, CT 3-60 HZ , CHP 60-90 HZ.

Additional Information:

8P - T EXTN
 STANDARD FLOOR MOUNT
 C/BOX 30 CU IN-0.75 NPT
 F1 CONDUIT BOX MOUNTING
 OIL RESISTANT SLEEVING ON LEADS

Performance Characteristics

1st Winding 1st Connection

Design: 14BD4008AA

Marks:

LOAD %	125.0	115.0	100.0	75.0	50.0	25.0	0.0
% EFF	72.59	73.5	74.54	74.08	70.43	58.17	0.00
% PF	62.08	59.44	56.81	45.89	34.96	22.53	8.78
AMPS	1.95	1.85	1.68	1.55	1.43	1.34	1.26

TORQ(FL)#FT	4.65	TORQ(LR)%FL	227.62	TORQ(BD)%FL	274.58
AMPS(LR)	5.98	PF AT START	0.57		

This motor is capable of two cold or one hot start with a maximum connected load inertia of 277 Lb-Ft Sq (11.66 Kg-meter Sq)at 100% voltage, where the load torque varies with the square of the speed. Acceleration time with maximum inertia and the above load type is 82 seconds. Safe stall time at 100% voltage is 183 seconds cold, 120 seconds hot. Rotor inertia is 0.11 Lb-Ft Sq (0 Kg-meter Sq).

Open Circuit A-C:	0.047	Short Circuit D-C:	0.006
Short Circuit A-C:	0.007	X/R Ratio:	2.251
Stator Slots:	36	Rotor Slots:	48

Speed Torque Current Curve (First Connection, First Speed)

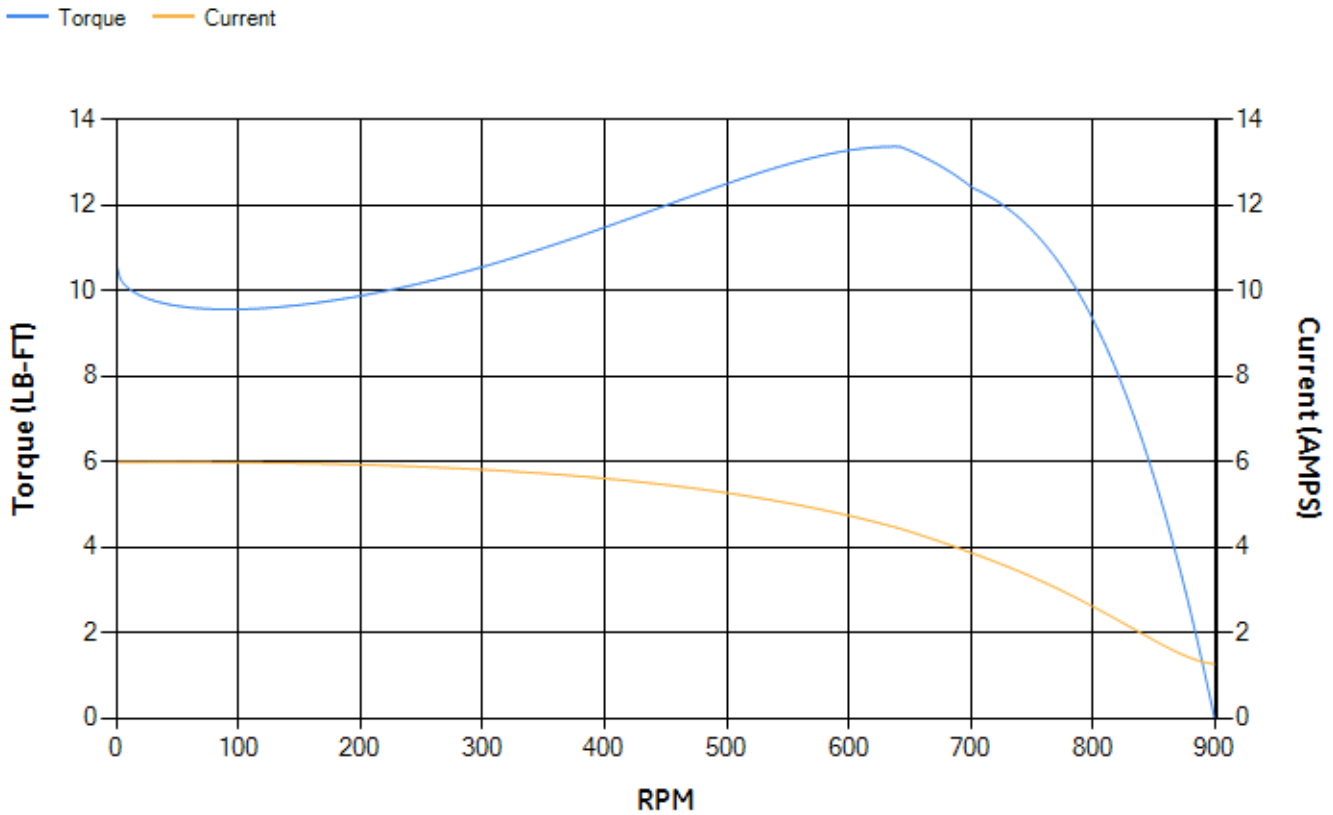

Marks:

NOTE 1: CONDUIT BOX MAY BE ASSEMBLED WITH ENTRANCE UP, DOWN OR TO EITHER SIDE.
 NOTE 2: F1 ASSEMBLY AS SHOWN. F2 ASSEMBLY CONDUIT BOX ON OPPOSITE SIDE FROM SHOWN LOCATION.

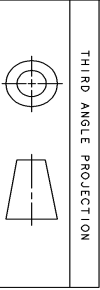
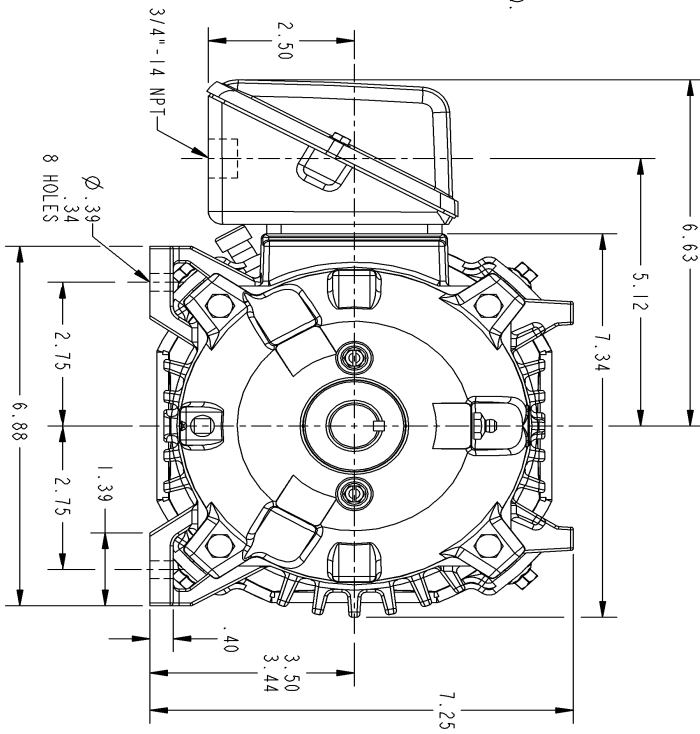
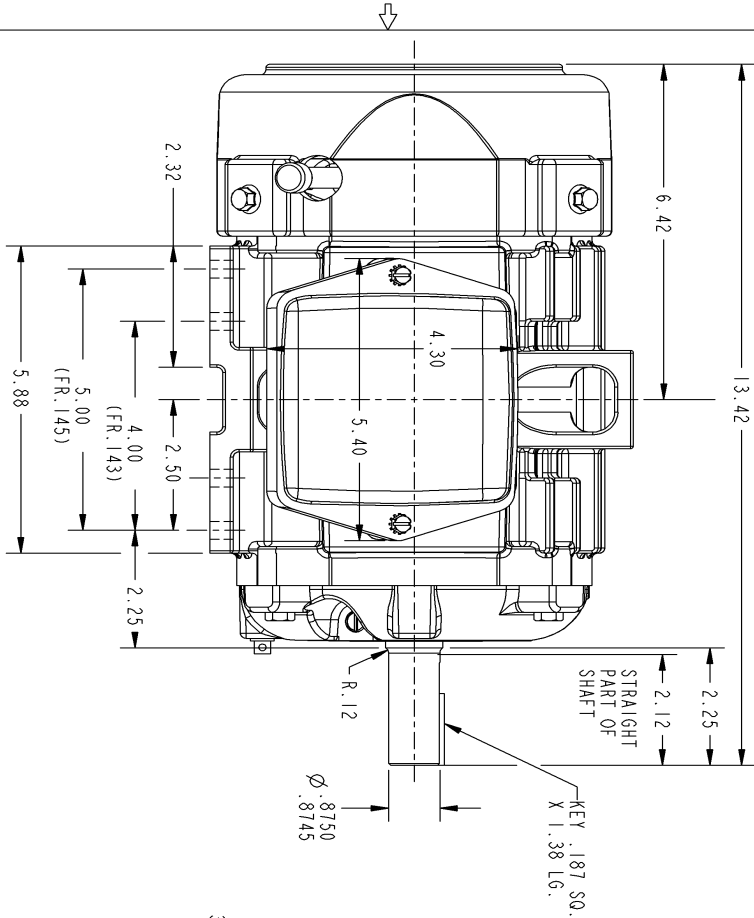

SIZE DRAWING NO.
B 4002B5814PAP5201

SM REV
1 1

REVISIONS			
REV.	DESCRIPTION	DATE	APPROVED
1.	REMOVED "ULTRA" FROM DESCRIPTION	05/21/03	DCMOHAN

SIGNATURES	DATE	GE Industrial Systems GENERAL ELECTRIC COMPANY Fort Wayne, Indiana
DRWN GART WARRINE	OCT 24/01	
CHECKED GART WARRINE	MAY 22/02	
ENGRS		
ISSUED GART WARRINE	JUN 05/02	
APPLIED PRACTICES		SIZE DRAWING B 4002B5814PAP5201 SCALE: 0.500 REF. NO.: 4002B5814PAP5201 SHEET 1 OF 1

INDUCTION MOTOR OUTLINE
 STANDARD CONSTRUCTION
 FWF: FR140T TEFC

DISTRIBUTION: PMP-18K15

Marks:

Connection Diagram
GEM2034E-FIG1



End shield Assembly		
Part Description	DE Side Part#	ODE Side Part#
End Shield	4004D5280PB1	4004D5280SG1
Bearing	235A2600AA01	235A2600AA01
Slinger/Inproseal	149C4399G15	149C4399G15

Fan & Fan Cover Assembly	
Part Description	Part#
Fan	4001A5914AM-G01
Fan Cover	4003C5785PA1

Conduit & Accessories Box Assembly	
Part Description	Part#
Conduit Box	4002B5718PA-G01

Mechanical Accessories	
Part Description	Part#
Brake	
Tachometer	