

# Product Information Packet

January 12, 2017

Data shown is for the current revision model #. Ensure your nameplate model # matches.

<b>Model Number:</b>	<b>5KS256CAA205D</b>
<b>Catalog Number:</b>	<b>E9673</b>
<b>Instruction Manual:</b>	GEI-56128
<b>Connection Diagram:</b>	GEM2034E-FIG3
<b>Outline Drawing:</b>	4002B5825RAP5201

Accessory Connection Diagrams			
<b>Bearing Thermocouple:</b>	None	<b>Heater:</b>	None
<b>RTD:</b>	None	<b>Thermistor:</b>	None
<b>Thermostat:</b>	3027JE-2A	<b>Winding Thermocouple:</b>	None
<b>Bearing RTD:</b>	None		

Table of Contents	
Specification	01
Performance Characteristics	02
Outline Drawing	03
Connection Drawing(s)	04

**Marks:**

<b>MODEL NUMBER:</b>	<b>5KS256CAA205D</b>	<b>Estimated Weight:</b>	350 Lbs
<b>Outline Drawing:</b>	4002B5825RAP5201	<b>Time Rating:</b>	CONT
<b>Connection Diagram:</b>	GEM2034E-FIG3	<b>Enclosure:</b>	TEFC
<b>Instruction Book:</b>	GEI-56128	<b>Encl Construction:</b>	XP
<b>Design Code:</b>	25BD1163A	<b>Ambient Max(°C):</b>	40
<b>Type:</b>	KS	<b>Alt Ambient Max(°C):</b>	--
<b>Frame:</b>	256T	<b>Insulation Class:</b>	F
<b>Phases:</b>	3	<b>NEMA Design:</b>	B
<b>Poles:</b>	4	<b>Nominal Efficiency:</b>	93 %
<b>Output Power:</b>	20HP 14.8KW	<b>Guaranteed Efficiency:</b>	91.7
<b>RPM:</b>	1775	<b>3/4 Load Efficiency:</b>	93.7
<b>Voltage:</b>	230/460	<b>KVA Code:</b>	G
<b>Hertz:</b>	60	<b>Max KVAR:</b>	6.2
<b>Amps - FL:</b>	47.6/23.8	<b>Power Factor:</b>	84.5
<b>Service Factor:</b>	1.00	<b>Bearing - DE:</b>	6309ZC3
<b>Alt Service Factor:</b>	--	<b>Bearing - ODE:</b>	6309ZC3

**Enclosure is Totally Enclosed Fan-Cooled**

---

**Stamped Nameplate Notes:**

EXPLOSION PROOF MOTOR  
TEMP CODE T3C  
THERMOSTAT LEADS TB1-TB2  
STAMP NP249A5571AD "CL I (C & D) CL II (F & G)"

**Additional Information:**

4P - T EXTN  
STANDARD FLOOR MOUNT  
C/BOX 127 CU IN-1.25 NPT  
F1 CONDUIT BOX MOUNTING  
AUX LEADS EXIT WITH MOTOR LEADS  
CL I C & D CL II F & G EXPLOSION PROOF MOTOR

**Performance Characteristics**

1st Winding 1st Connection

**Design: 25BD1163A**

**Marks:**

LOAD %	125.0	115.0	100.0	75.0	50.0	25.0	0.0
% EFF	92.13	92.56	93.31	93.72	93.6	91.02	0.00
% PF	86.1	85.75	84.73	80.95	71.89	49.85	4.4
AMPS	29.5	27.12	23.68	18.5	13.91	10.31	8.62

<b>TORQ(FL)#FT</b>	59.21	<b>TORQ(LR)%FL</b>	203.53	<b>TORQ(BD)%FL</b>	254.91
<b>AMPS(LR)</b>	135.12	<b>PF AT START</b>	0.45		

This motor is capable of two cold or one hot start with a maximum connected load inertia of 653 Lb-Ft Sq (27.49 Kg-meter Sq)at 100% voltage, where the load torque varies with the square of the speed. Acceleration time with maximum inertia and the above load type is 43 seconds. Safe stall time at 100% voltage is 98 seconds cold, 62 seconds hot. Rotor inertia is 3.04 Lb-Ft Sq (0.13 Kg-meter Sq).

<b>Open Circuit A-C:</b>	0.483	<b>Short Circuit D-C:</b>	0.014
<b>Short Circuit A-C:</b>	0.024	<b>X/R Ratio:</b>	5.127
<b>Stator Slots:</b>	48	<b>Rotor Slots:</b>	40

**Speed Torque Current Curve (First Connection, First Speed)**

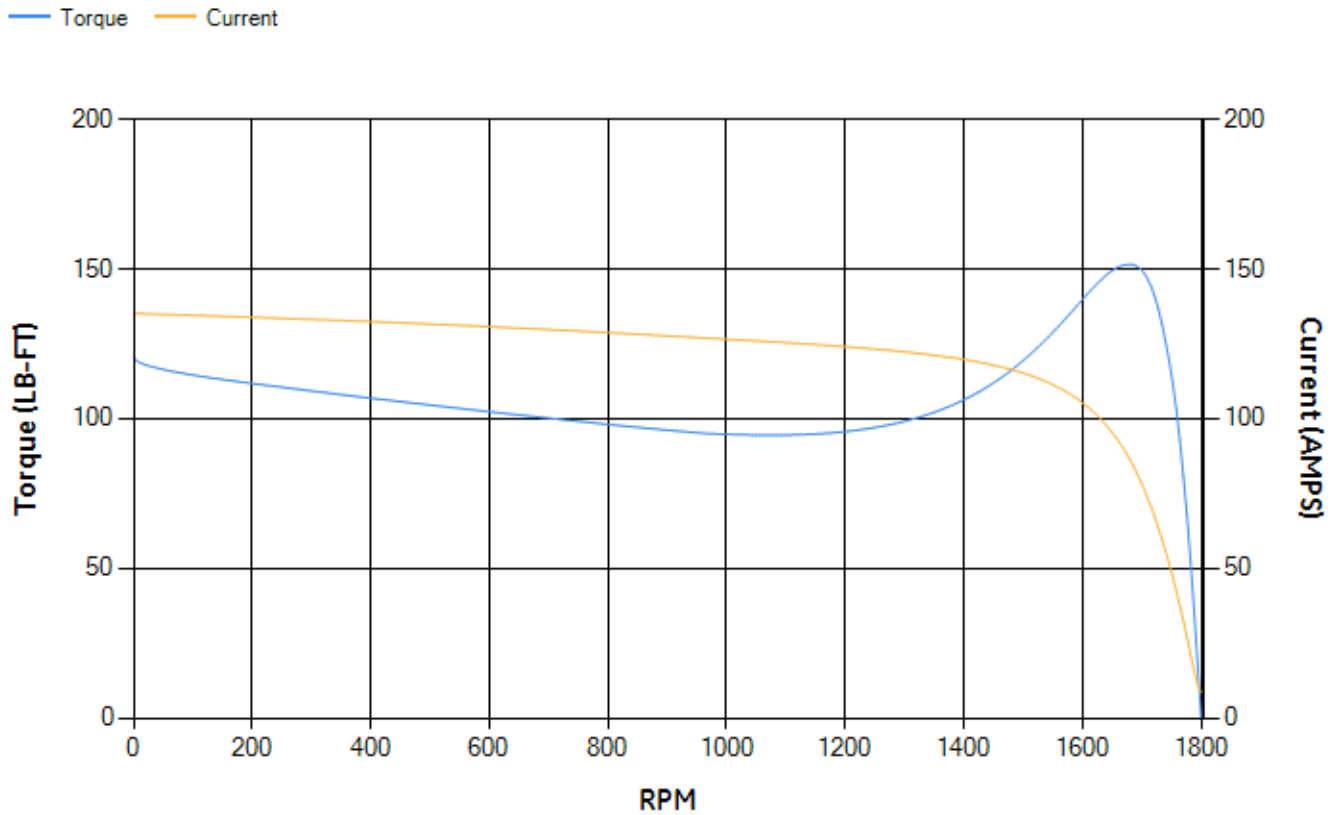

NAME:500957145 OBJECT:4002B5825RAP5201 DATE:23-Nov-07 19:23:09

Marks:

NOTE 1: CONDUIT BOX MAY BE ASSEMBLED WITH ENTRANCE UP, DOWN OR TO EITHER SIDE.  
 NOTE 2: F1 ASSEMBLY AS SHOWN. F2 ASSEMBLY CONDUIT BOX ON OPPOSITE SIDE FROM SHOWN LOCATION.

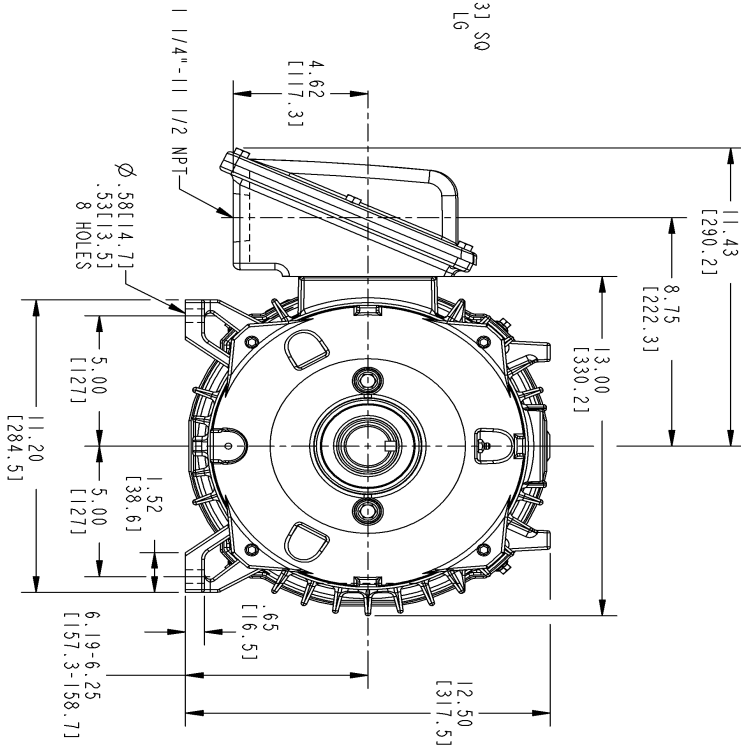
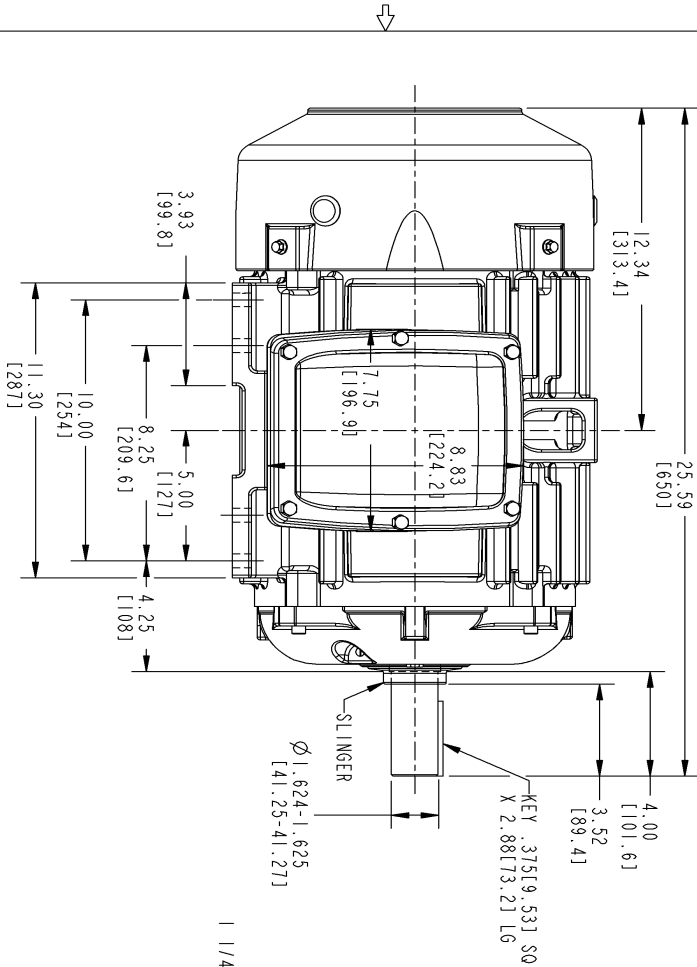

REV.	DESCRIPTION	DATE	APPROVED
1	DUAL DIMENSION ADDED	SMITHUN	HEMANTH

SIZE DRAWING NO. 4002B5825RAP5201

SH 1 REV

REVISIONS

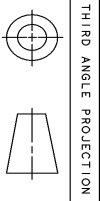

THIRD ANGLE PROJECTION

SIGNATURES	DATE	GE Industrial Systems	GENERAL ELECTRIC COMPANY
DRAWN: GARY WARRNER	JUN 21/02		Fort Wayne, Indiana
CHECKED: GARY WARRNER	JUN 21/02		
ISSUED: GARY WARRNER	JUL 04/02		

INDUCTION MOTOR OUTLINE  
 STANDARD CONSTRUCTION  
 FME: FR250T FCXR XSD ULTRA

SIZE DRAWING: 4002B5825RAP5201  
 SCALE: 0.250 REF. NO.: 4002B5825RAP5201 SHEET 1 OF 1

DISTRIBUTION: PMP-18K15

Marks:

**Connection Diagram**  
**GEM2034E-FIG3**

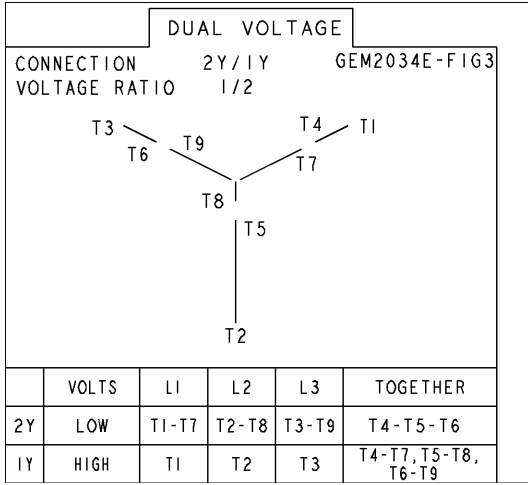

**Thermostat Connection**  
**3027JE-2A**

