

Product Information Packet

November 8, 2016

Data shown is for the current revision model #. Ensure your nameplate model # matches.

Model Number:	5KS184XAA100D3
Catalog Number:	M8927
Instruction Manual:	GEI-56128
Connection Diagram:	GEM2034E-FIG1
Outline Drawing:	4002B5818PBP5311

Accessory Connection Diagrams			
Bearing Thermocouple:	None	Heater:	None
RTD:	None	Thermistor:	None
Thermostat:	None	Winding Thermocouple:	None
Bearing RTD:	None		

Table of Contents

Specification	01
Performance Characteristics	02
Outline Drawing	03
Connection Drawing(s)	04
Spare parts	05



Marks:

MODEL NUMBER:	5KS184XAA100D3	Estimated Weight:	101 Lbs
Outline Drawing:	4002B5818PBP5311	Time Rating:	CONT
Connection Diagram:	GEM2034E-FIG1	Enclosure:	TEFC
Instruction Book:	GEI-56128	Encl Construction:	841
Design Code:	18BD0103A	Ambient Max(°C):	40
Type:	KS	Alt Ambient Max(°C):	--
Frame:	184TC	Insulation Class:	H
Phases:	3	NEMA Design:	B
Poles:	2	Nominal Efficiency:	88.5 %
Output Power:	5HP 3.7KW	Guaranteed Efficiency:	87.5
RPM:	3530	3/4 Load Efficiency:	89.3
Voltage:	460	KVA Code:	J
Hertz:	60	Max KVAR:	1.9
Amps - FL:	6.6	Power Factor:	80.5
Service Factor:	1.15	Bearing - DE:	6307ZC3
Alt Service Factor:	--	Bearing - ODE:	6206ZC3

Enclosure is Totally Enclosed Fan-Cooled

Stamped Nameplate Notes:

IEEE-STD-841-2009
 DE BRG 35BC03JP30 ODE BRG 30BC02JP30
 STAMP NP249A5564P051 AS BELOW:
 MODEL:5KS184XAA100D3 S/N: XXX
 CSA CERTIFIED CSA09.2216219 FOR EX NA IIC 200 C GC
 CL1 ZONE2 AEXNAIIC 200C FOR CL1DIV2 GRP ABCD 200C
 IN -25C <= AMB <= 40C, 1.0 SF ON SINE-WAVE PWR
 SURF TEMP 200 C AT 1.15 SF ON SINE-WAVE PWR
 OR 200 C VT OR 215 C CT OR 200 C CHP PWM CONTROL
 ALTERNATE RATING FOR PWM CONTROL 1.0 SF 40 C AMB
 VT 0-60 HZ, CT 3-60 HZ, CHP 60-90 HZ.

Additional Information:

2P - T EXTN
 STANDARD FLOOR MOUNT
 C/BOX 55 CU IN-1.00 NPT
 F1 CONDUIT BOX MOUNTING
 "C" FACE AT DE ENDSHIELD
 PAINTED FRAME ID & SHAFT,
 FAN COVER INSIDE & ODE E/S OUTSIDE
 ROUTINE AND 5 POINT VIBRATION TESTS INCL IN C/BOX
 INPRO SEAL BOTH ENDS
 GROUND SCREW ON FRAME
 SHAFT RUNOUT LIMIT .001" TIR
 COPPER WASHER UNDER HEADS OF BEARING CAP BOLTS
 APPLY TITE-SEAL (A50CD427A) ON BEARING CAP SCREWS, RABBETS,
 AND PLUG THREADS

OIL RESISTANT SLEEVING ON LEADS

Performance Characteristics

1st Winding 1st Connection

Design: 18BD0103A

Marks:

LOAD %	125.0	115.0	100.0	75.0	50.0	25.0	0.0
% EFF	88.58	88.92	89.48	89.29	87.84	81.49	0.00
% PF	83.43	82.52	84.25	74.86	63.69	42.37	9.05
AMPS	7.92	7.33	6.21	5.25	4.18	3.39	2.61

TORQ(FL)#FT	7.44	TORQ(LR)%FL	213.31	TORQ(BD)%FL	337.03
AMPS(LR)	43.21	PF AT START	0.4		

This motor is capable of two cold or one hot start with a maximum connected load inertia of 45 Lb-Ft Sq (1.89 Kg-meter Sq)at 100% voltage, where the load torque varies with the square of the speed. Acceleration time with maximum inertia and the above load type is 38 seconds. Safe stall time at 100% voltage is 77 seconds cold, 56 seconds hot. Rotor inertia is 0.16 Lb-Ft Sq (0.01 Kg-meter Sq).

Open Circuit A-C:	0.305	Short Circuit D-C:	0.01
Short Circuit A-C:	0.017	X/R Ratio:	3.956
Stator Slots:	36	Rotor Slots:	28

Speed Torque Current Curve (First Connection, First Speed)

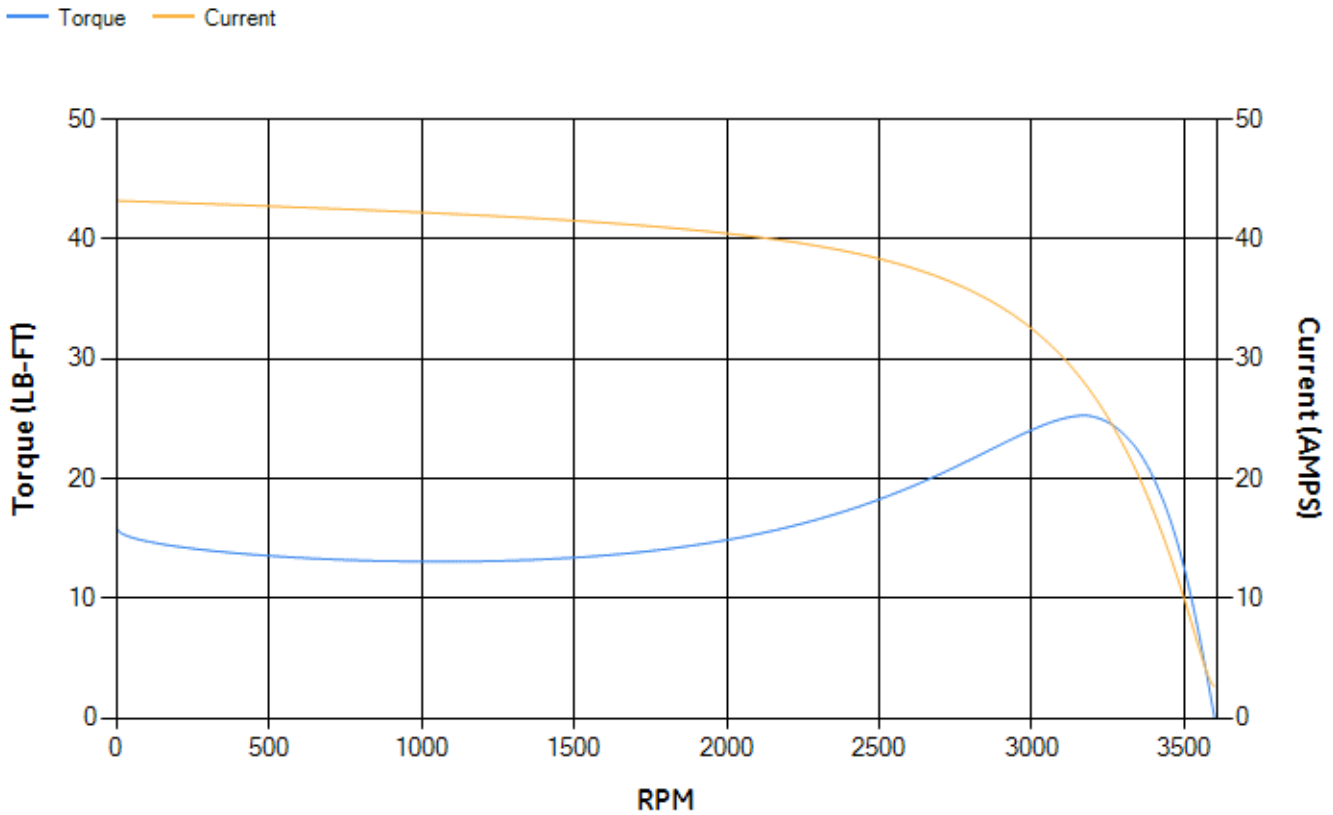

Marks:

NOTE 1: CONDUIT BOX MAY BE ASSEMBLED WITH ENTRANCE UP OR DOWN.
 NOTE 2: F1 ASSEMBLY AS SHOWN, F2 ASSEMBLY CONDUIT BOX ON OPPOSITE SIDE FROM SHOWN LOCATION.
 NOTE 3: MOUNTING SURFACES WILL BE SQUARE AND CONCENTRIC WITH SHAFT WITHIN .004 T.I.R.
 NOTE 4: SHAFT RUNOUT WILL NOT EXCEED .001 T.I.R.
 NOTE 5: ALL DIMENSIONS ARE IN INCHES, BRACKETED DIMENSIONS ARE IN METRIC (MILLIMETERS).

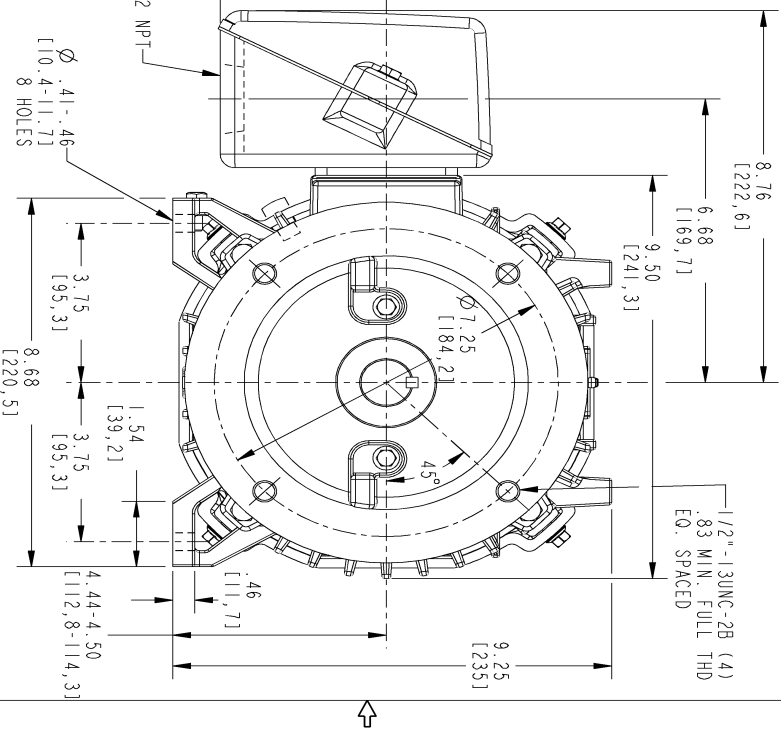
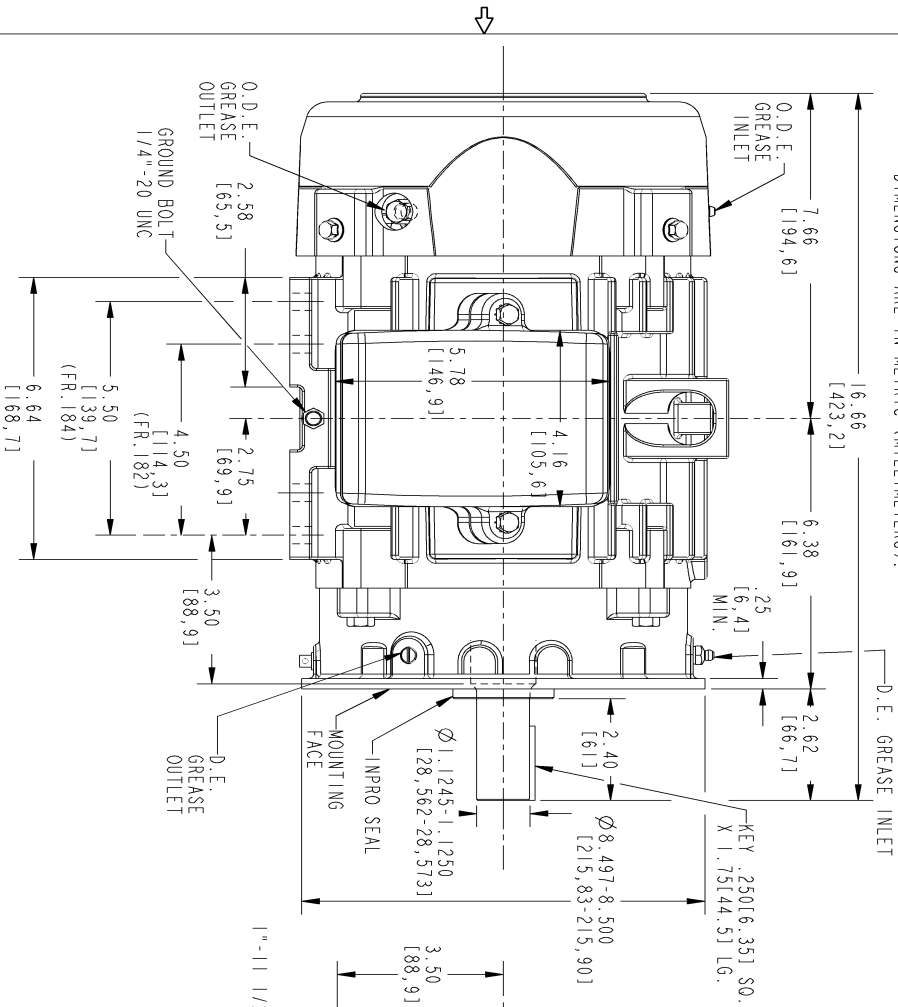

SIZE	DRAWING NO.	REV	SHEET
B	4002B5818PBP5311	0	1

REV.	DESCRIPTION	DATE	APPROVED

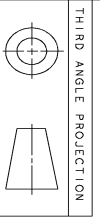

SIGNATURES		DATE	GE Motors GENERAL ELECTRIC COMPANY
MODEL	TEJASNI	06/09/15	
DETAIL	TEJASNI	06/09/15	TITLE INDUCTION MOTOR OUTLINE IEEE-841 SPEC, "C" FACE AT DE (850° RABBIT) FR182/84 TC TERC 4002B5818PBP5311
CHECKED	KARTHIK	06/09/15	
ENGR	VENKAT	06/09/15	
QC			
ISSUED	TEJASNI	06/09/15	SIZE DRAWING B
SCALE: 0.400		REF. No.: 4002B5818PBP5301	REV 0
SHEET 1 OF 1			

Marks:

Connection Diagram
GEM2034E-FIG1

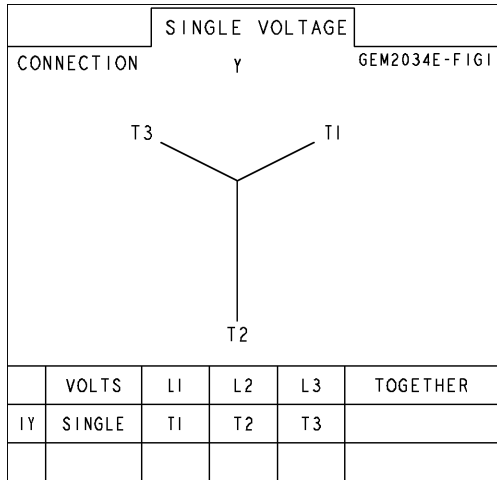

End shield Assembly		
Part Description	DE Side Part#	ODE Side Part#
End Shield	4004D5286PE1	4004D5281SG1
Bearing	235A2601AA01	235A2602AA01
Slinger/Inproseal	316A5384AJ1	4002B5914AG2

Fan & Fan Cover Assembly	
Part Description	Part#
Fan	4001A5914AM-G01
Fan Cover	4003C5786PA1

Conduit & Accessories Box Assembly	
Part Description	Part#
Conduit Box	4002B5721PA-G01

Mechanical Accessories	
Part Description	Part#
Brake	
Tachometer	