

SHEET

REV

52A111746 0

SIZE DRAWING NO. A

THIRD ANGLE PROJECTION

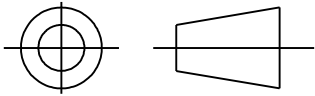

REVISIONS

REV.	DESCRIPTION	DATE	APPROVED

CONTROL SURFACES & DIMENSIONS

(P) PROC.
(E) ENG.
(A) APPL.
(R) REG.

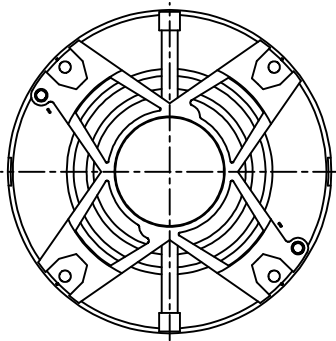

VIEW SHOWING P.E. VENTILATION OPENINGS

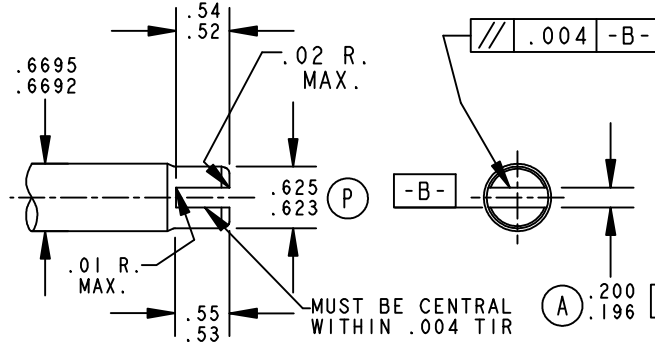

MUST BE CENTRAL WITHIN .004 TIR

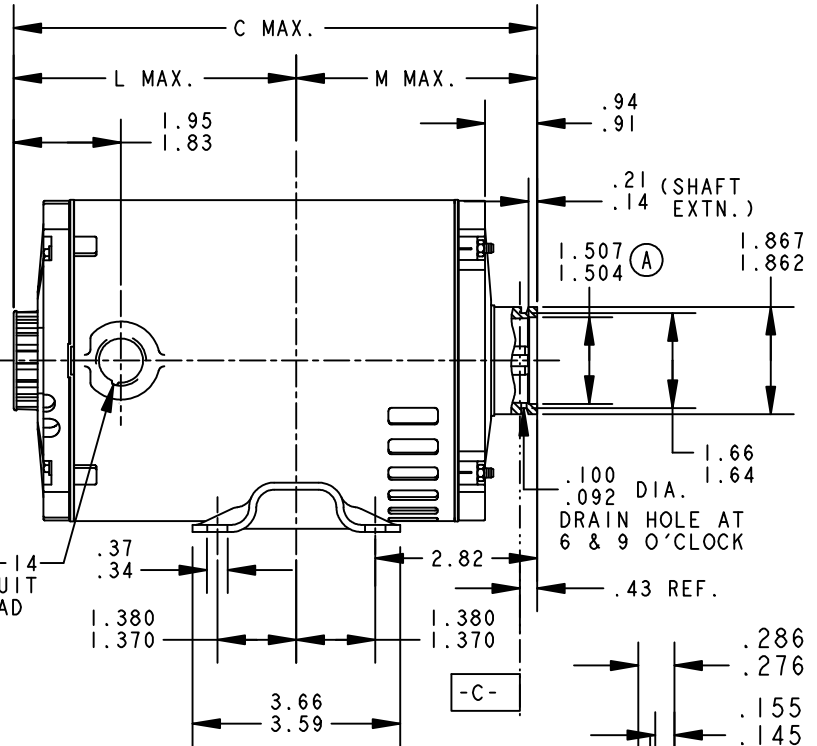
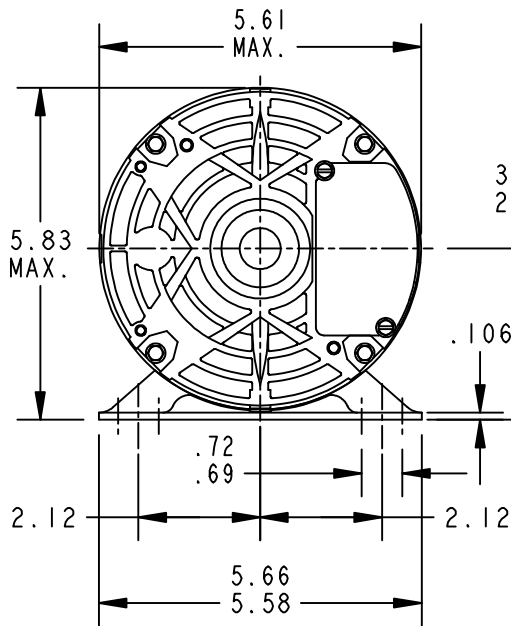

I	KH	32	48Y	7.69	3.55	4.28
P	TYPE	GE SIZE	NEMA FR	C	L	M

SIGNATURES		DATE
MODEL	SUDHA	06/09/06
DETAIL	.	.
CHECKED	.	.
ENGRG	.	.
MFG	.	.
FOR ADDITIONAL INFO REFER TO:	QUALITY	.
APPLIED PRACTICES	ISSUED	DURGA 06/09/06
MATERIAL	SOLID MODEL: 52A111746	



REGAL-BELOIT CORPORATION

TITLE

OUTLINE

CARBONATOR PUMP - OPEN -

WELDED BASE - BALL BRG.

SIZE DRAWING

A

52A111746

REV 0

SCALE: 0.250 REF. No: . SHEET 1 of 1