

# Product Information Packet

November 9, 2016

Data shown is for the current revision model #. Ensure your nameplate model # matches.

<b>Model Number:</b>	<b>5KS286SAA114D3</b>
<b>Catalog Number:</b>	<b>M9828</b>
<b>Instruction Manual:</b>	GEI-56128
<b>Connection Diagram:</b>	GEM2034E-FIG7
<b>Outline Drawing:</b>	4002B5828PAP5221

Accessory Connection Diagrams			
<b>Bearing Thermocouple:</b>	None	<b>Heater:</b>	None
<b>RTD:</b>	None	<b>Thermistor:</b>	None
<b>Thermostat:</b>	None	<b>Winding Thermocouple:</b>	None
<b>Bearing RTD:</b>	None		

## Table of Contents

Specification	01
Performance Characteristics	02
Outline Drawing	03
Connection Drawing(s)	04
Spare parts	05



**Marks:**

<b>MODEL NUMBER:</b>	<b>5KS286SAA114D3</b>	<b>Estimated Weight:</b>	510 Lbs
<b>Outline Drawing:</b>	4002B5828PAP5221	<b>Time Rating:</b>	CONT
<b>Connection Diagram:</b>	GEM2034E-FIG7	<b>Enclosure:</b>	TEFC
<b>Instruction Book:</b>	GEI-56128	<b>Encl Construction:</b>	X\$D
<b>Design Code:</b>	28BD0153B	<b>Ambient Max(°C):</b>	40
<b>Type:</b>	KS	<b>Alt Ambient Max(°C):</b>	60
<b>Frame:</b>	286TS	<b>Insulation Class:</b>	H
<b>Phases:</b>	3	<b>NEMA Design:</b>	B
<b>Poles:</b>	2	<b>Nominal Efficiency:</b>	92.4 %
<b>Output Power:</b>	30HP 22.2KW	<b>Guaranteed Efficiency:</b>	91.7
<b>RPM:</b>	3545	<b>3/4 Load Efficiency:</b>	93.4
<b>Voltage:</b>	575	<b>KVA Code:</b>	G
<b>Hertz:</b>	60	<b>Max KVAR:</b>	4.2
<b>Amps - FL:</b>	26.1	<b>Power Factor:</b>	93.0
<b>Service Factor:</b>	1.15	<b>Bearing - DE:</b>	6310ZC3
<b>Alt Service Factor:</b>	1.00	<b>Bearing - ODE:</b>	6310ZC3

**Enclosure is Totally Enclosed Fan-Cooled**

---

**Stamped Nameplate Notes:**

STAMP NP249A5564P051 AS BELOW:  
 MODEL:5KS286SAA114D3 S/N: XXX  
 CSA CERTIFIED CSA09.2216219 FOR EX NA IIC 200C GC  
 CL 1 ZONE2 AEX NA IIC 200C;CL 1 DIV2 GRP ABCD 200C  
 IN -40C <= AMB <= 40C, 1.0 SF ON SINE-WAVE PWR  
 SURF TEMP 260C AT 1.15SF ON SINE-WAVE PWR  
 OR 200C VT OR 215C CT OR 215C CHP PWM CONTROL  
 ALTERNATE RATING FOR PWM CONTROL 1.0SF 40C AMB  
 VT 0 - 60 HZ, CT 15-60 HZ, CHP 60-90 HZ.

**Additional Information:**

2P - TS EXTN  
 STANDARD FLOOR MOUNT  
 C/BOX 137 CU IN-1.50 NPT  
 F1 CONDUIT BOX MOUNTING  
 OIL RESISTANT SLEEVING ON LEADS

**Performance Characteristics**

1st Winding 1st Connection

**Design: 28BD0153B**

**Marks:**

LOAD %	125.0	115.0	100.0	75.0	50.0	25.0	0.0
% EFF	91.41	91.93	92.79	93.37	93.42	91.05	0.00
% PF	92.41	92.7	92.9	92.37	89.5	77.14	9.72
AMPS	33.24	30.31	26.06	19.53	13.43	8	4.7

<b>TORQ(FL)#FT</b>	44.4	<b>TORQ(LR)%FL</b>	283.26	<b>TORQ(BD)%FL</b>	272.51
<b>AMPS(LR)</b>	173.68	<b>PF AT START</b>	0.43		

This motor is capable of two cold or one hot start with a maximum connected load inertia of 111 Lb-Ft Sq (4.67 Kg-meter Sq)at 100% voltage, where the load torque varies with the square of the speed. Acceleration time with maximum inertia and the above load type is 18 seconds. Safe stall time at 100% voltage is 38 seconds cold, 21 seconds hot. Rotor inertia is 3.25 Lb-Ft Sq (0.14 Kg-meter Sq).

<b>Open Circuit A-C:</b>	1.041	<b>Short Circuit D-C:</b>	0.013
<b>Short Circuit A-C:</b>	0.025	<b>X/R Ratio:</b>	5.016
<b>Stator Slots:</b>	48	<b>Rotor Slots:</b>	38

**Speed Torque Current Curve (First Connection, First Speed)**

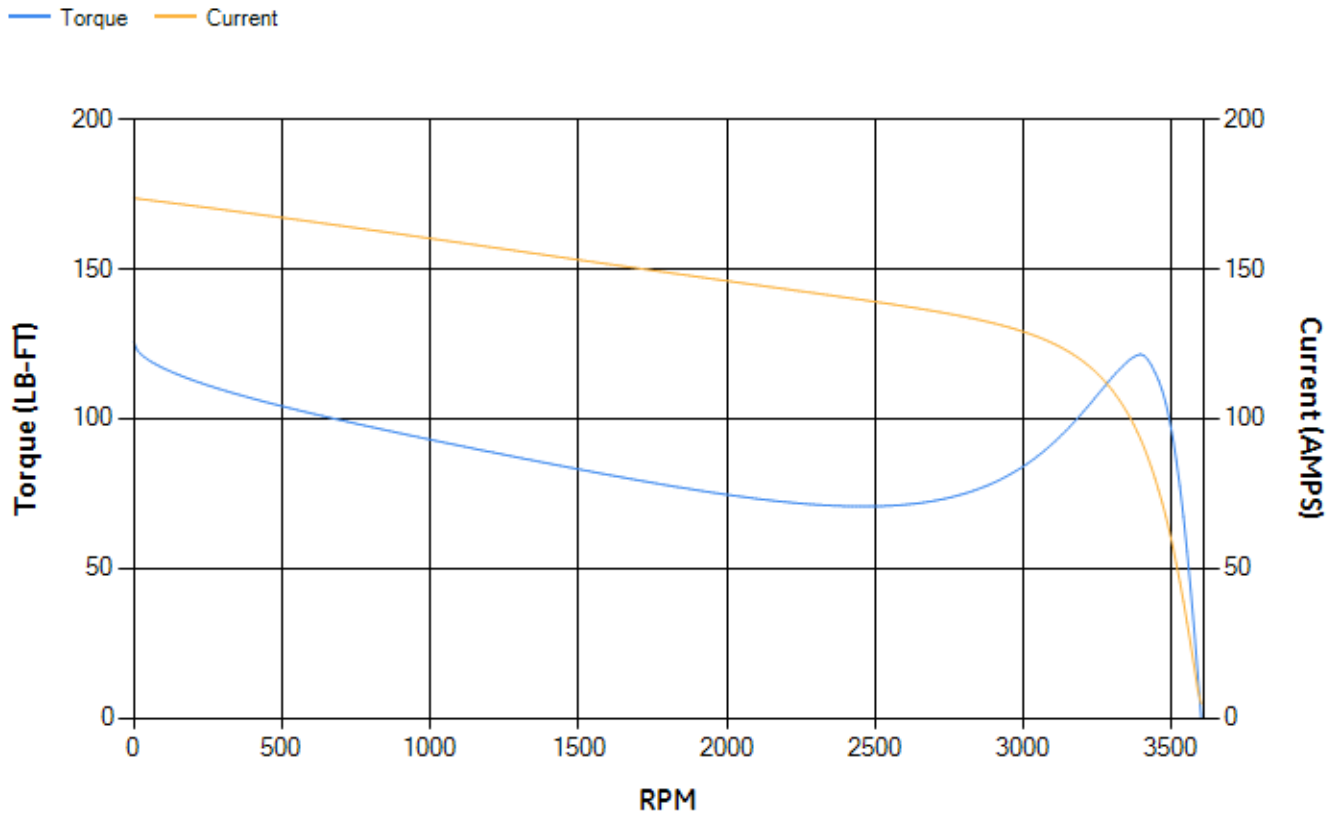

Marks:

NOTE 1: CONDUIT BOX MAY BE ASSEMBLED WITH ENTRANCE UP, DOWN OR TO EITHER SIDE.  
 NOTE 2: F1 ASSEMBLY AS SHOWN. F2 ASSEMBLY CONDUIT BOX ON OPPOSITE SIDE FROM SHOWN LOCATION.  
 NOTE 3: SHAFT RUNOUT WILL NOT EXCEED .002 T.I.R.  
 NOTE 4: ALL DIMENSIONS ARE IN INCHES & BRACKETED DIMENSIONS ARE IN METRIC (MILLIMETERS)

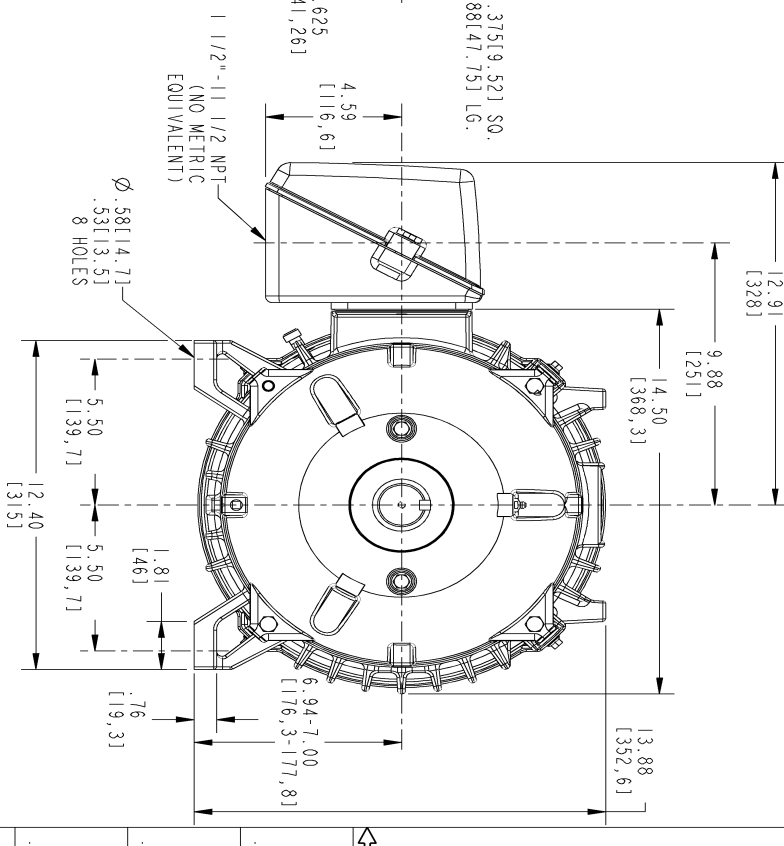
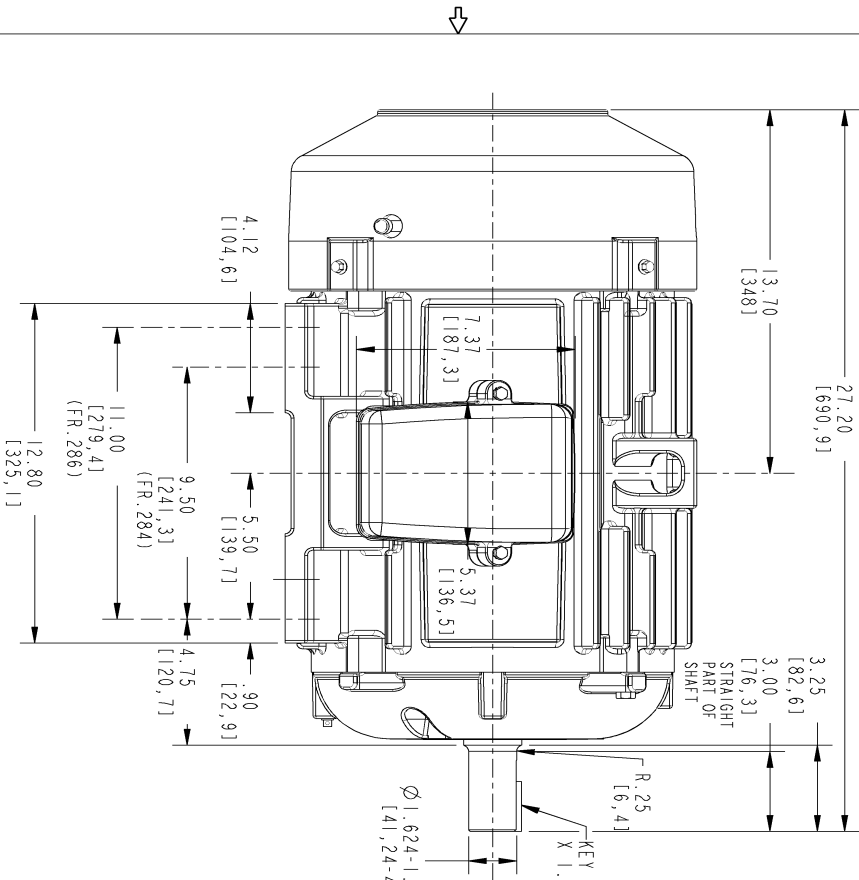

SIZE B DRAWING NO. 4002B5828PAP5221

REV.	DESCRIPTION	DATE	APPROVED
1	ISAC # 12-0882	08/30/12	ADINARAYANA

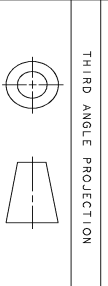

SIGNATURES	DATE
DRMAN GARY WARRNER	JUL 03/02
CHECKED GARY WARRNER	JUL 03/02
ENGRB GARY WARRNER	JUL 03/02
ISSUED GARY WARRNER	JUL 03/02

**GE Industrial Systems**  
**GENERAL ELECTRIC COMPANY**  
 Fort Wayne, Indiana  
**INDUCTION MOTOR OUTLINE**  
 STANDARD CONSTRUCTION  
 FWE: FR284/286T'S TFC XSD ULTRA  
 SIZE DRAWING 4002B5828PAP5221  
 SCALE: 0.250 REF. NO: 4002B5828PAP221 SHEET 0F 1

DISTRIBUTION: PMP-1BK15

Marks:

**Connection Diagram**  
**GEM2034E-FIG7**



End shield Assembly		
Part Description	DE Side Part#	ODE Side Part#
End Shield	4004D5284PB1	4004D5284SE1
Bearing	235A2608AA01	235A2608AA01
Slinger/Inproseal	149C4399G03	149C4399G03

Fan & Fan Cover Assembly	
Part Description	Part#
Fan	159C6704G02
Fan Cover	4003C5789PA1

Conduit & Accessories Box Assembly	
Part Description	Part#
Conduit Box	4002B5728PA-G01

Mechanical Accessories	
Part Description	Part#
Brake	
Tachometer	