

Product Information Packet

January 12, 2017

Data shown is for the current revision model #. Ensure your nameplate model # matches.

Model Number:	5KS449SAG223A
Catalog Number:	E9524
Instruction Manual:	GEI-56128
Connection Diagram:	GEM2034E-FIG1
Outline Drawing:	225B6500HW

Accessory Connection Diagrams			
Bearing Thermocouple:	None	Heater:	None
RTD:	235A3027RY	Thermistor:	None
Thermostat:	None	Winding Thermocouple:	None
Bearing RTD:	None		

Table of Contents	
Specification	01
Performance Characteristics	02
Outline Drawing	03
Connection Drawing(s)	04

Marks:

MODEL NUMBER:	5KS449SAG223A	Estimated Weight:	2610 Lbs
Outline Drawing:	225B6500HW	Time Rating:	CONT
Connection Diagram:	GEM2034E-FIG1	Enclosure:	TEFC
Instruction Book:	GEI-56128	Encl Construction:	X\$D
Design Code:	49ED1015E	Ambient Max(°C):	40
Type:	KS	Alt Ambient Max(°C):	XX
Frame:	449T	Insulation Class:	F
Phases:	3	NEMA Design:	B
Poles:	4	Nominal Efficiency:	95.0 %
Output Power:	150HP 111KW	Guaranteed Efficiency:	94.5
RPM:	1785	3/4 Load Efficiency:	95.2
Voltage:	2300	KVA Code:	G
Hertz:	60	Max KVAR:	43.2
Amps - FL:	34.8	Power Factor:	85.0
Service Factor:	1.15	Bearing - DE:	6318ZC3
Alt Service Factor:	XX	Bearing - ODE:	6318ZC3

Enclosure is Totally Enclosed Fan-Cooled

Stamped Nameplate Notes:

MAX INT AND EXT SURFACE TEMP FOR NORM OPER
 AT RATED COND 215 DEG C
 VIBRATION LIMIT = 0.055 IPS
 GREASE POLYREX EM
 TEMP CONT HTR LDS H 115V 125W
 STAMP NP249A5564P009 AS FOLLOWS:
 MAXIMUM SPACE HEATER SURFACE
 TEMPERATURE FOR NORMAL OPERATION
 AT RATED CONDITIONS 172 DEG C

Additional Information:

4 POLE, T SHAFT EXTN
 FORMED COIL
 TEMP CONTRL 115V HEATER LEADS TO ACC BOX
 100 OHM WINDING RTD LEADS TO ACC BOX
 700 Cu. In. CBOX

Performance Characteristics

1st Winding 1st Connection

Design: 49ED1015E

Marks:

LOAD %	125.0	115.0	100.0	75.0	50.0	25.0	0.0
% EFF	94.72	94.91	95.32	95.2	94.62	91.68	0.00
% PF	86.3	86.08	85.27	82.01	73.72	52.28	4.65
AMPS	42.94	39.53	34.55	26.97	20.13	14.65	12.01

TORQ(FL)#FT	441.64	TORQ(LR)%FL	204.53	TORQ(BD)%FL	234.29
AMPS(LR)	209.81	PF AT START	0.34		

This motor is capable of two cold or one hot start with a maximum connected load inertia of 3683 Lb-Ft Sq (155.05 Kg-meter Sq)at 100% voltage, where the load torque varies with the square of the speed. Acceleration time with maximum inertia and the above load type is 39 seconds. Safe stall time at 100% voltage is 97 seconds cold, 47 seconds hot. Rotor inertia is 77.42 Lb-Ft Sq (3.26 Kg-meter Sq).

Open Circuit A-C:	0.792	Short Circuit D-C:	0.03
Short Circuit A-C:	0.046	X/R Ratio:	11.358
Stator Slots:	60	Rotor Slots:	44

Speed Torque Current Curve (First Connection, First Speed)

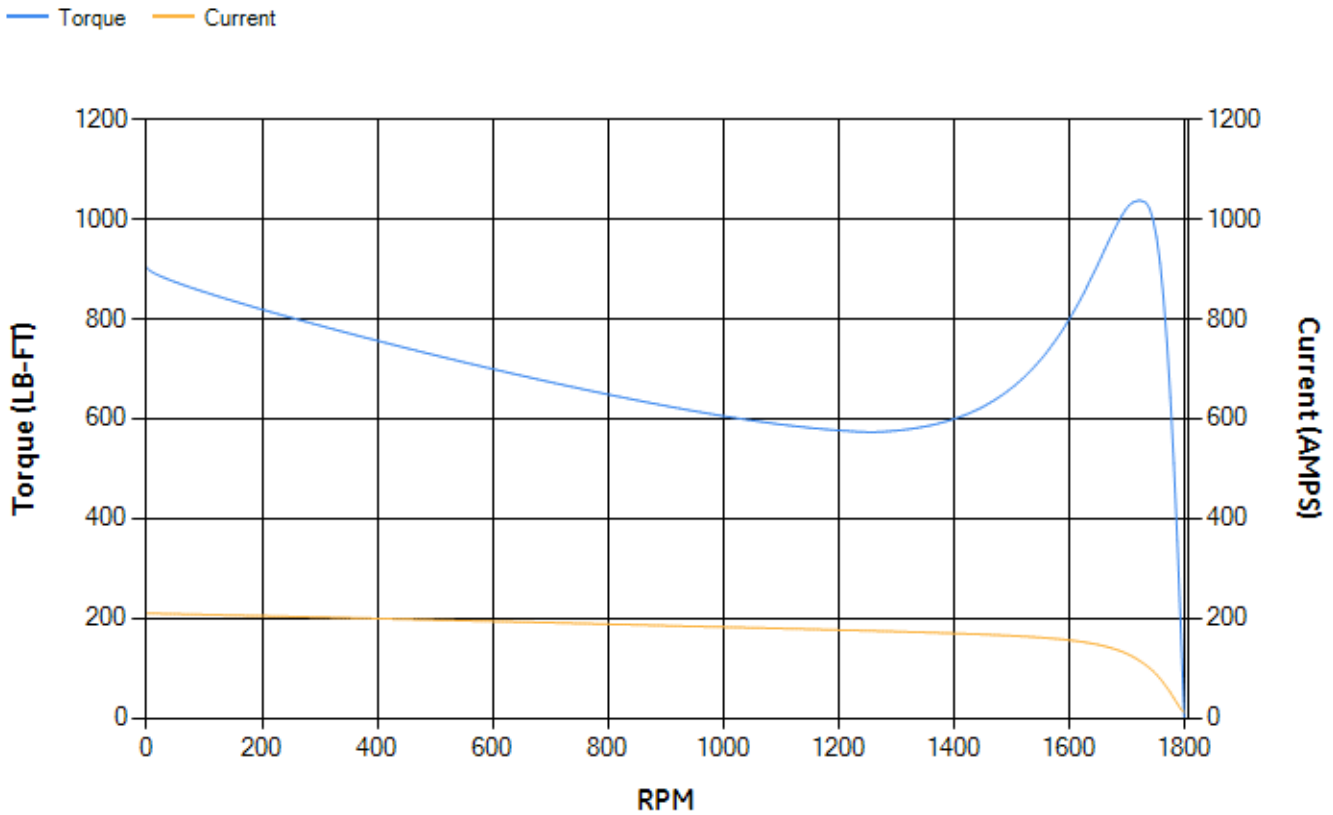

Marks:

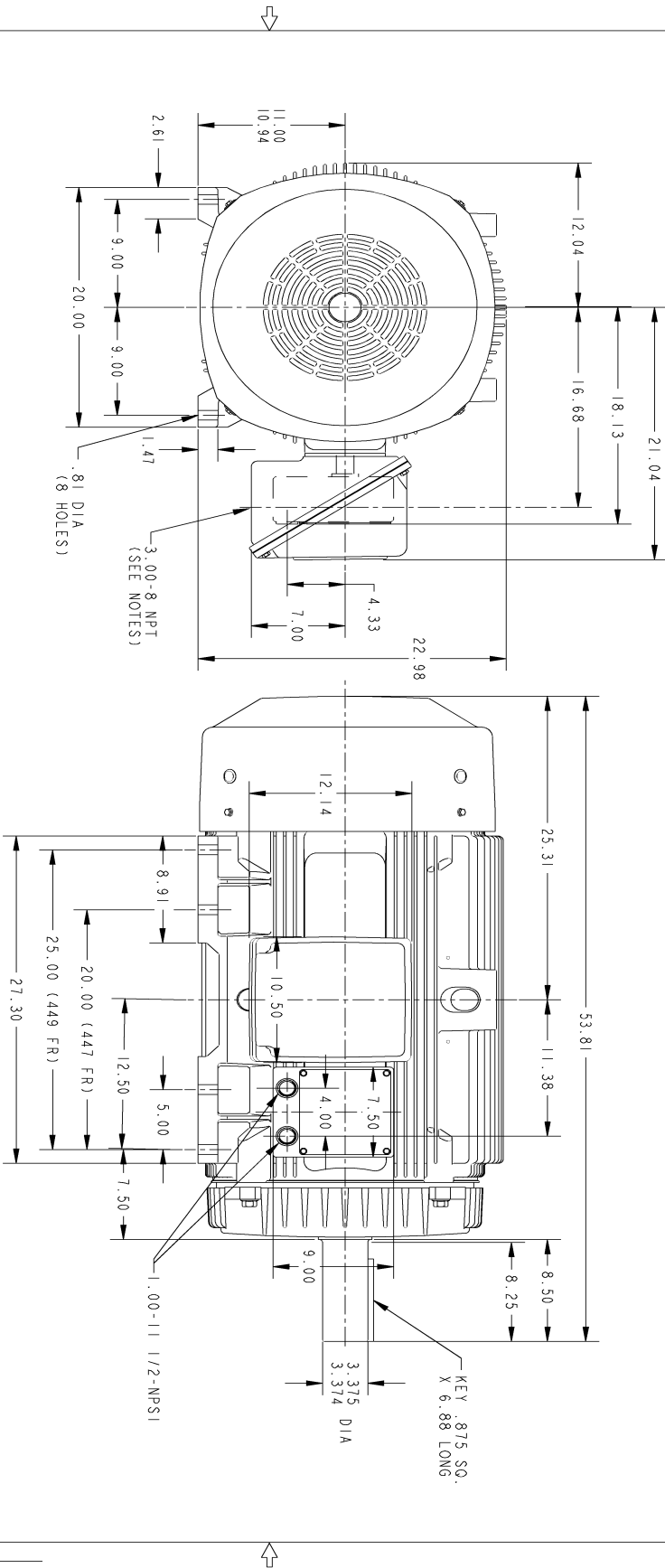

REVISIONS			
REV	DESCRIPTION	DATE	APPROVED
1	ISAAC #12-0320 LAXMIKANTH	03/28/12	NANCHI

SIZE B DWG NO 225B6500HW SH 1 REV 1

- NOTES:
1. CONDUIT BOX MAY BE PLACED WITH THE ENTRANCE DOWN, UP OR TOWARD OPPOSITE DRIVE END.
 2. F-1 ASSEMBLY AS SHOWN.
 3. F-2 ASSEMBLY HAS CONDUIT BOX ON OPPOSITE SIDE.

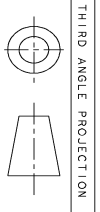

UNLESS OTHERWISE SPECIFIED		SIGNATURES		DATE	
DIMENSIONS ARE IN INCHES		DRAWN M. R. SURINK		05/18/94	
TOLERANCES ON:		CHECKED M. R. B.		05/18/94	
2 PL. DECIMALS ±					
3 PL. DECIMALS ±					
ANGLES ±					
FRACTIONS ±					
MATERIALS:		ISSUED		05/18/94	
APPLIED PRACTICES:		CAD NO. 0H449-225B6500HW		SIZE B	
		SCALE .125		SHEET 1 OF 1	

GE Motors
Fort Wayne, Indiana

OUTLINE
447/449T TFC 700 CU IN. BOX
ACCESSORY BOX

DWG NO 225B6500HW

DISTR TO

Marks:

Connection Diagram
GEM2034E-FIG1

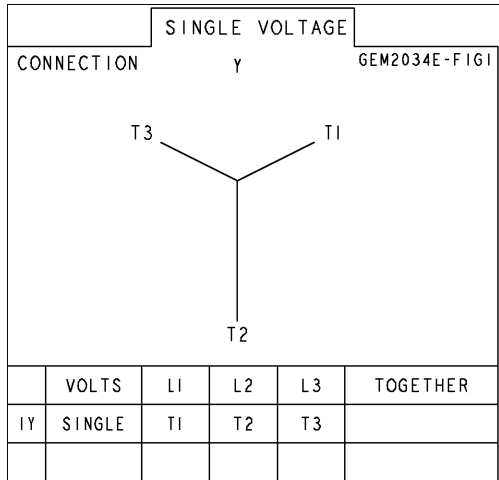



SH 1 REV 3 DWG NO 235A3027RY SIZE A	THIRD ANGLE PROJECTION		REVISIONS			
			REV	DESCRIPTION	DATE	APPROVED
			2	ISAAC 02-3381 NRS	12/20/02	
			3	P6 CONNECTED NARAYANAN	05/30/06	BHASKAR

PROPRIETARY AND CONFIDENTIAL
 This document is the property of General Electric Company and contains proprietary and confidential information of General Electric Company. This document is loaned on the express condition that neither it nor the information contained therein shall be disclosed to others without the express consent of GE Motors & Industrial Systems and that the information shall be used by the recipient only as approved expressly by GE Motors & Industrial Systems. Also, this document shall be returned to the Company upon its request.
 GE MOTORS & INDUSTRIAL SYSTEMS

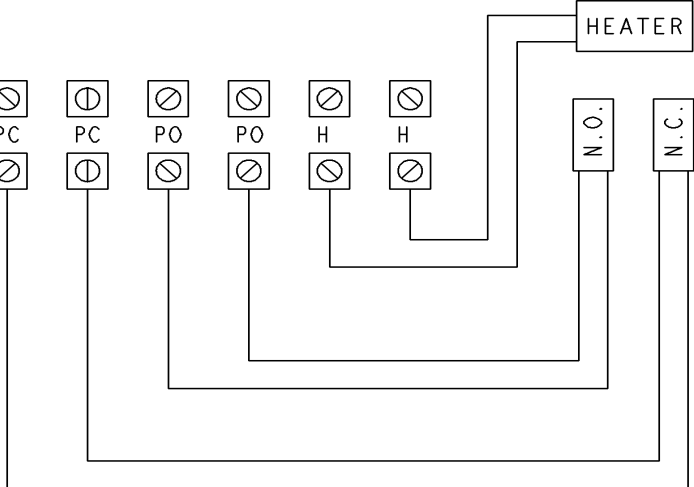
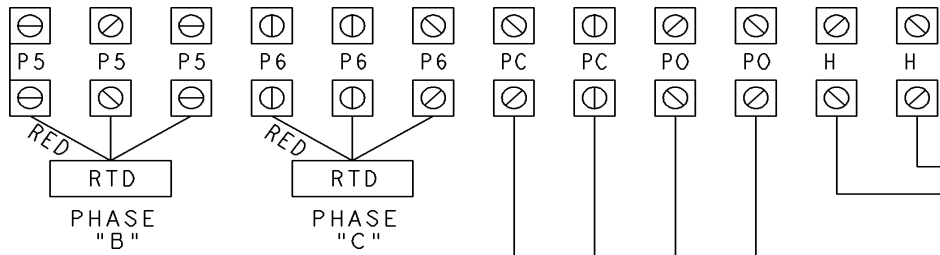
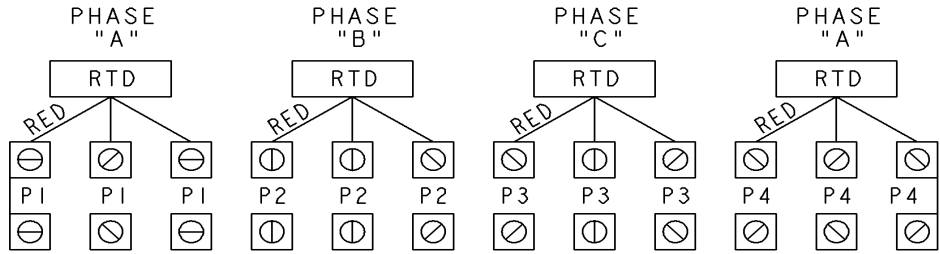
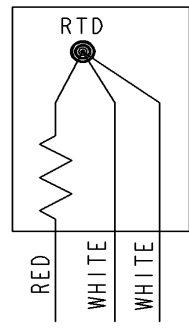

- NOTE 1: TERMINAL LABELS ARE PROVIDED FOR ACCESSORIES THAT MAY OR MAY NOT BE INCLUDED WITH THE MOTOR.
- NOTE 2: SPARE RTDS (P7 & P8) FURNISHED IN CASE OF FAILURE IN OTHER RTDS (P1-P6). PHASE LOCATION WILL DEPEND UPON NUMBER OF POLES WINDING CONFIGURATION.
- NOTE 3: IT IS RECOMMENDED THAT RTDS BE GROUNDED AT EITHER THE MACHINE OR CONNECTED TO A GROUNDED CONTROL CIRCUIT. FOR PROPER OPERATION DO NOT GROUND AT THE MACHINE IF CONNECTED TO A GROUND CIRCUIT AT THE CONTROL.

UNLESS OTHERWISE SPECIFIED DIMENSIONS ARE IN INCHES TOLERANCES ON: 2 PL DECIMALS ± 3 PL DECIMALS ± ANGLES ± FRACTIONS ± MATERIAL: APPLIED PRACTICES:	SIGNATURES		DATE	GE Motors & Industrial Systems Fort Wayne, Indiana	
	DRAWN R.D.COE		09/21/01		
	CHECKED R.D.C.		09/21/01		
	ISSUED		09/24/01		
CONNECTION DIAGRAM WINDING RTD'S & T'STATS & HEATERS				DISTR TO	
CAD NO. 235A3027RY		SIZE A	FSCM NO		DWG NO 235A3027RY
		SCALE .95			SHEET 1 OF 1

