

TYPE	OUTPUT		POLE	TIME RATING	VOLTAGE V	Hz	SYN SPEED R.P.M
	HP.	KW.					
AEHGTK	450	336	8	CDNT.	2300/4160	60	900

TOTALLY ENCLOSED FAN-COOLED TYPE, SQUIRREL-CAGE ROTOR

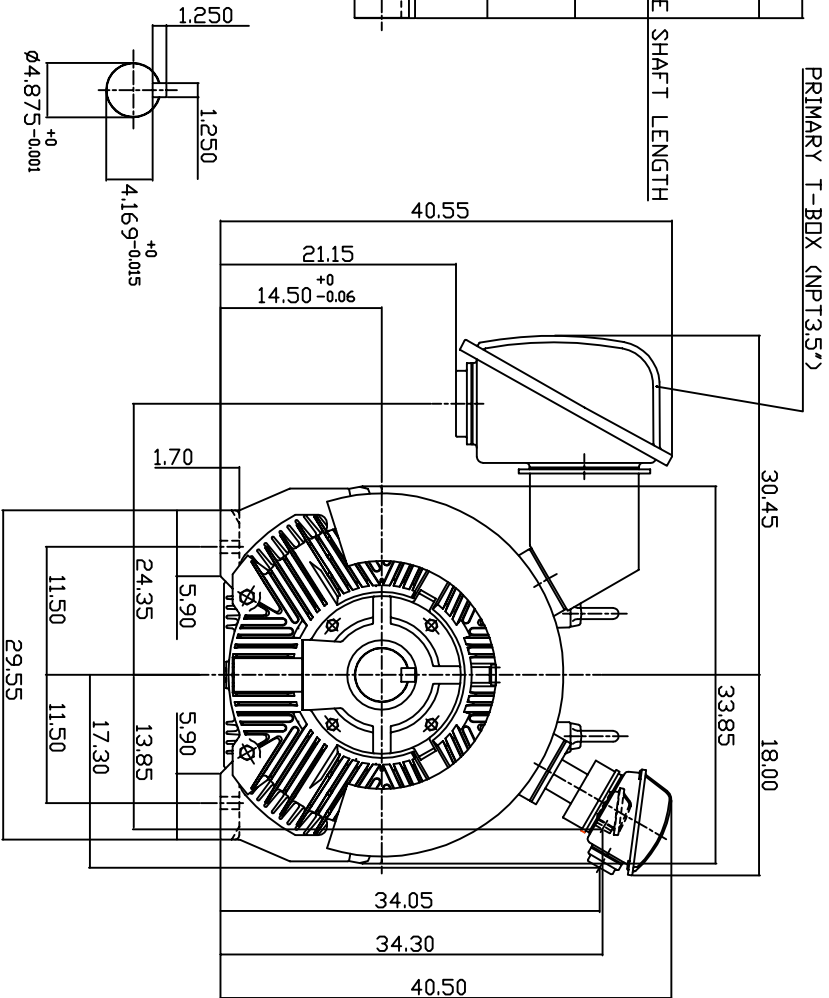
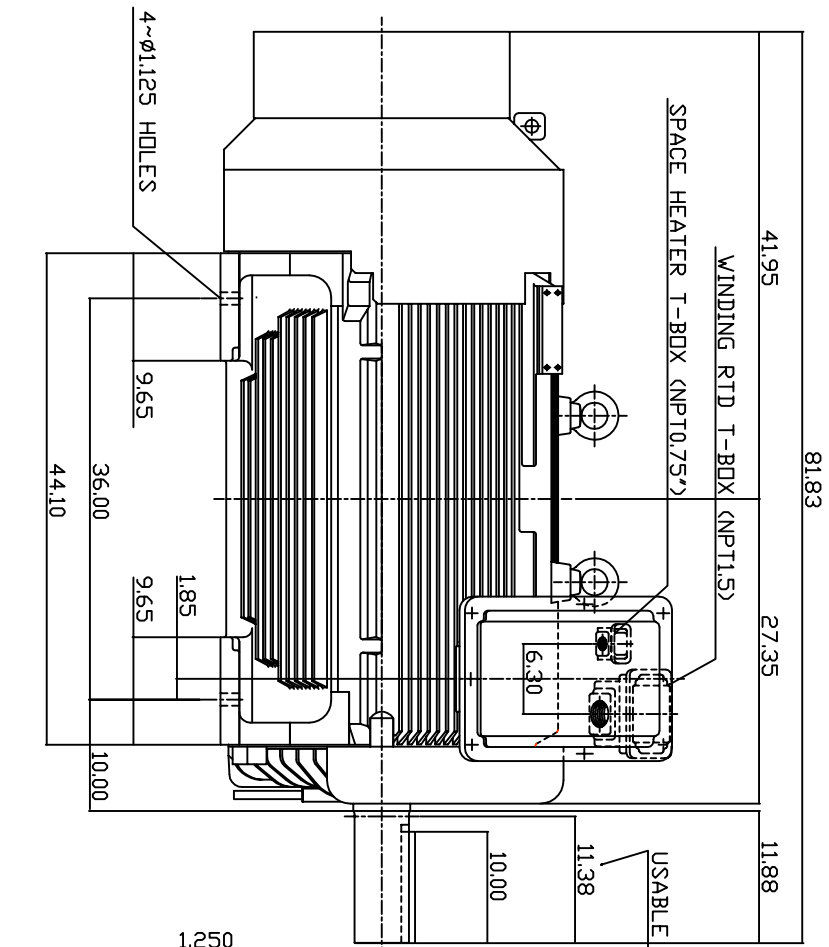

- NOTE: DIMENSIONS IN INCH.
1. FRAME NO. 5810C
 2. F CLASS INSULATION, S.F.1.15
 3. FOR BELT DRIVE APPLICATIONS
 4. WITH SPACE HEATER 120 VOLT SINGLE PHASE 200 WATTS
 5. WITH 100 OHM PLATINUM WINDING RTD'S 2/PHASE
 6. BEARING SIZE: DRIVE END: NU326
NON-DRIVE END: 6322
 7. MOTOR APPROX. WEIGHT: 5900 LBS

TW-66C

DWN.	W.LLIN	MAY-03-2003
CHKD.	W.LLIN	MAY-03-2003
APPD.	C.WANG	MAY-03-2003

DATE	OUTLINE DIMENSIONS
MAY 6, 2004	3-PHASE INDUCTION MOTOR
CATALOG NO. KG4508R	
DWG NO. 3A040T460	REV: 00