

TYPE	OUTPUT		POLE	TIME RATING	VOLTAGE V	Hz	SYN SPEED R.P.M
	HP.	KW.					
AEHGTK	250	187	8	COND.	2300/4160	60	900

TOTALLY ENCLOSED FAN-COOLED TYPE. SQUIRREL-CAGE ROTOR

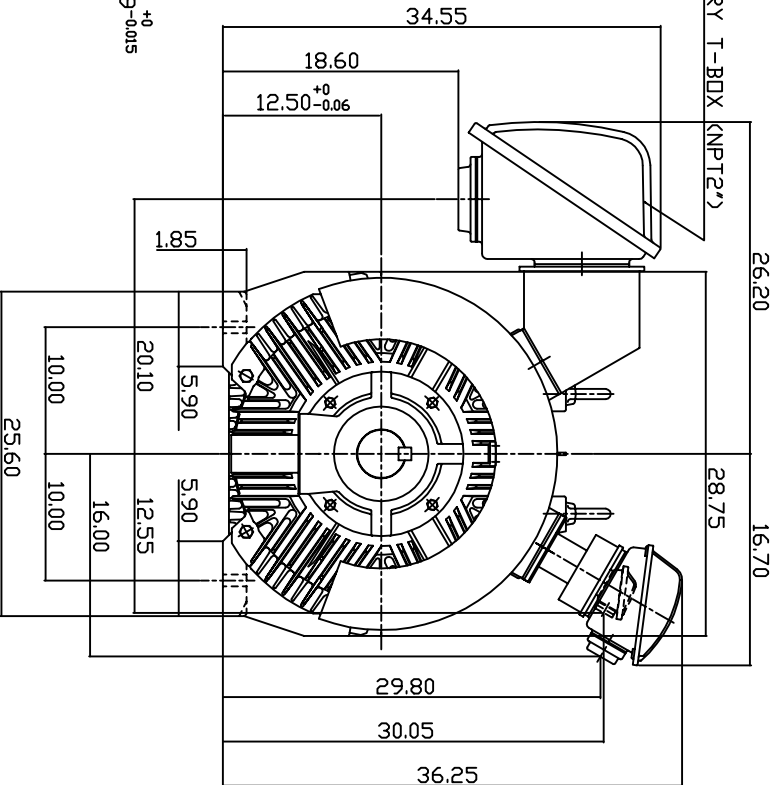
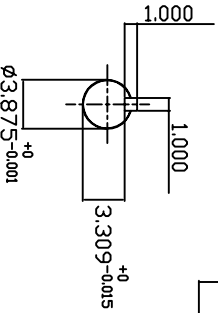
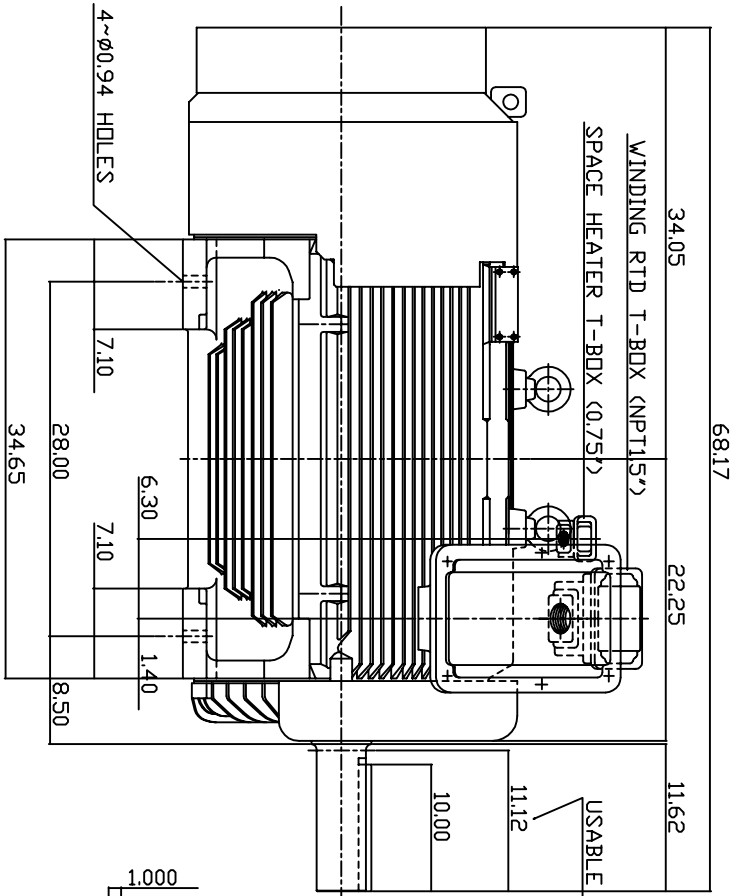

NOTE: 1. DIMENSIONS IN INCH.

2. FRAME NO. 5009C
3. F CLASS INSULATION, S.F.115
4. FOR BELT DRIVE APPLICATIONS
5. WITH SPACE HEATER 120 VOLT SINGLE PHASE 200 WATTS
6. WITH 100 OHM PLATINUM WINDING RTD'S 2/PHASE
7. BEARING SIZE: DRIVE END: NU324
NON-DRIVE END: 6320
8. MOTOR APPROX. WEIGHT: 4300 LBS

TW-56C

DWN.	W.LLIN	APR-08-2003
CHKD.	W.LLIN	APR-08-2003
APPD.	C.WANG	APR-08-2003

DATE	MAY 5, 2004	OUTLINE DIMENSIONS
CATALOG NO.	KG2508R	
3-PHASE INDUCTION MOTOR		



DWG NO. 3A040T4482 REV. 00