

TYPE	OUTPUT		POLE	TIME RATING	VOLTAGE V	Hz	SYN.SPEED R.P.M
	HP.	kw.					
AEHHXU	75	55.6	8	CONT.	230/460	60	900

TOTALLY ENCLOSED FAN-COOLED TYPE, SQUIRREL-CAGE ROTOR

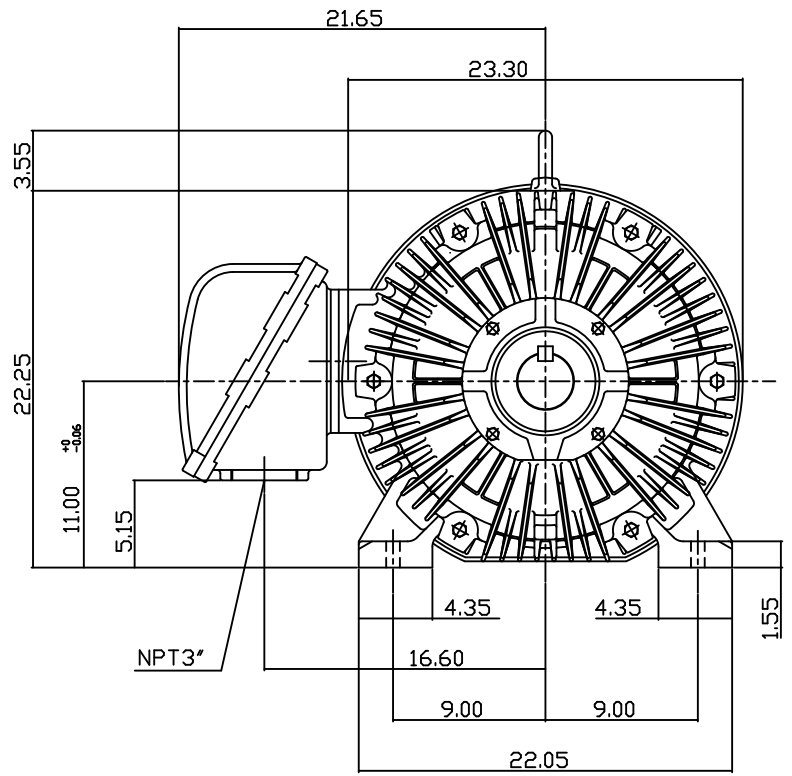
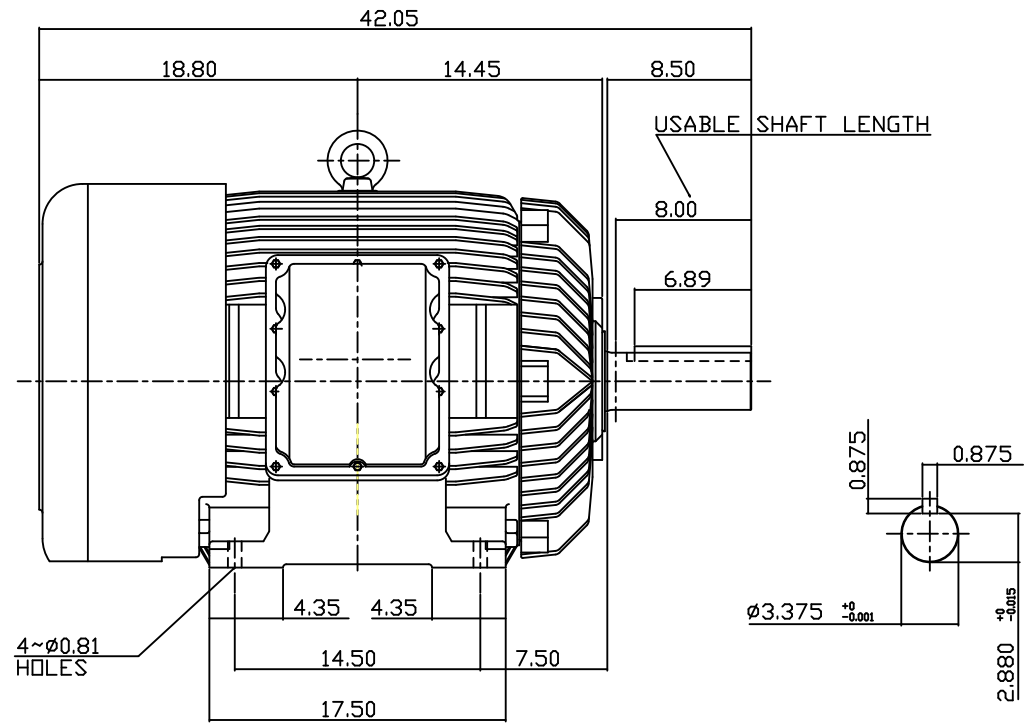

- NOTE:
1. DIMENSIONS IN INCH.
  2. FRAME NO. 444T
  3. F CLASS INSULATION, S.F.1.15
  4. UL EXPLOSION PROOF
  5. SUITABLE FOR DIVISION I, CLASS I, GROUP D, CLASS II, GROUP E,F,G.
  6. BEARING SIZE: DRIVE END: 6318  
NON-DRIVE END: 6318
  7. MOTOR APPROX. WEIGHT: 1600 LBS

TX-56

DATE AUG. 30, 2013	OUTLINE DIMENSIONS
CATALOG NO. XP0758	3-PHASE INDUCTION MOTOR
DWG NO.	REV: 00
3A040T3271-1	

DWN.	W.L.LIN	APR-07-2003
CHKD.	W.L.LIN	APR-07-2003
APPD.	C.WANG	APR-07-2003

TECO Westinghouse