

TYPE	OUTPUT		POLE	TIME RATING	VOLTAGE V	Hz	SYN.SPEED R.P.M
	HP.	kW.					
AEFAFP	150	111.9	6	CONT.	460	60	1200

TOTALLY ENCLOSED FAN-COOLED TYPE. SQUIRREL-CAGE ROTOR

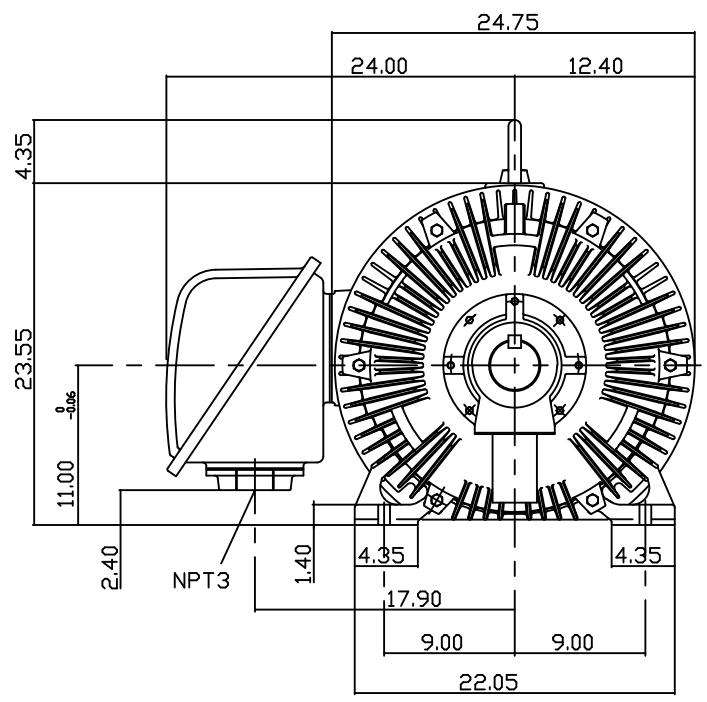
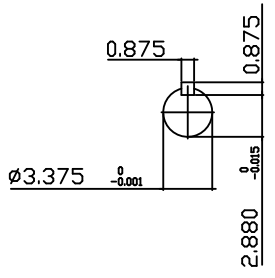
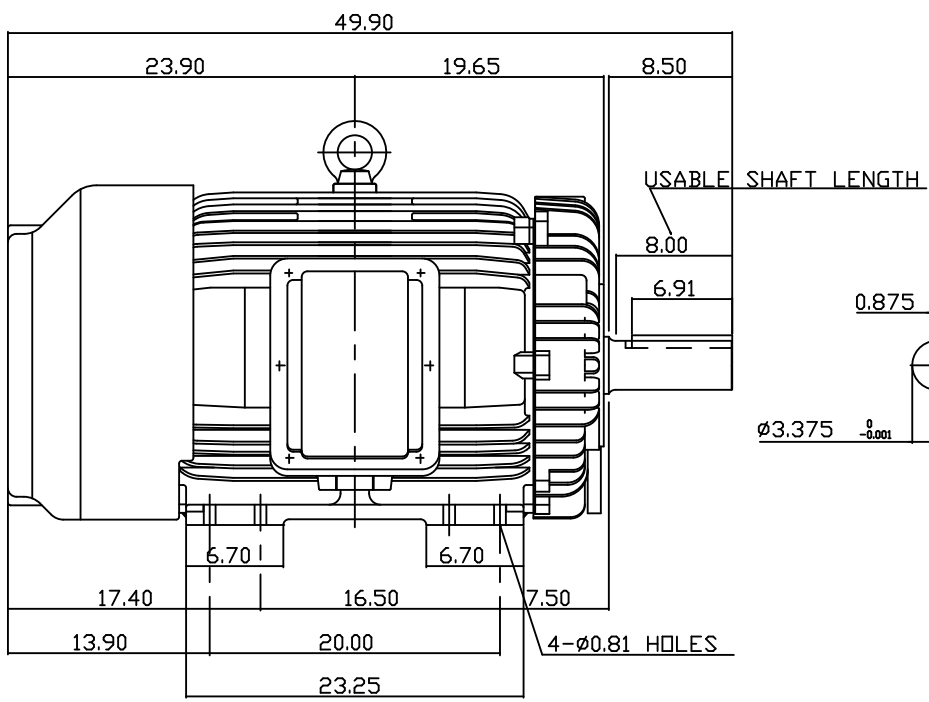

- NOTE:
1. DIMENSIONS IN INCH
  2. FRAME NO. 447T
  3. F CLASS INSULATION, S.F.115
  4. FOR DIRECT FLEXIBLE COUPLING
  5. ENCLOSURE: IP54
  6. BEARING SIZE: DRIVE END: 6320  
NON-DRIVE END: 6316
  7. APPROX. WEIGHT: 2380 LBS
  8. KLIXON 9700 THERMOSTAT, ONE PER PHASE, LEADS TERMINATE IN MAIN LEAD T-BOX. NORMALLY CLOSED.

TW-56C

DWN.	C.COOK	OCT-30-2015

DATE	OCT. 30, 2015	OUTLINE DIMENSIONS
CATALOG #	QT1256	3-PHASE INDUCTION MOTOR
TEC Westinghouse		DWG NO. REV: 00
		QT1256