

| TYPE | OUTPUT | | POLE | TIME RATING | VOLTAGE V | Hz | SYN.SPEED R.P.M |
|-------|--------|------|------|-------------|-----------|----|-----------------|
| | HP. | kW. | | | | | |
| AEHGK | 100 | 74.6 | 8 | CONT. | 2300/4160 | 60 | 900 |

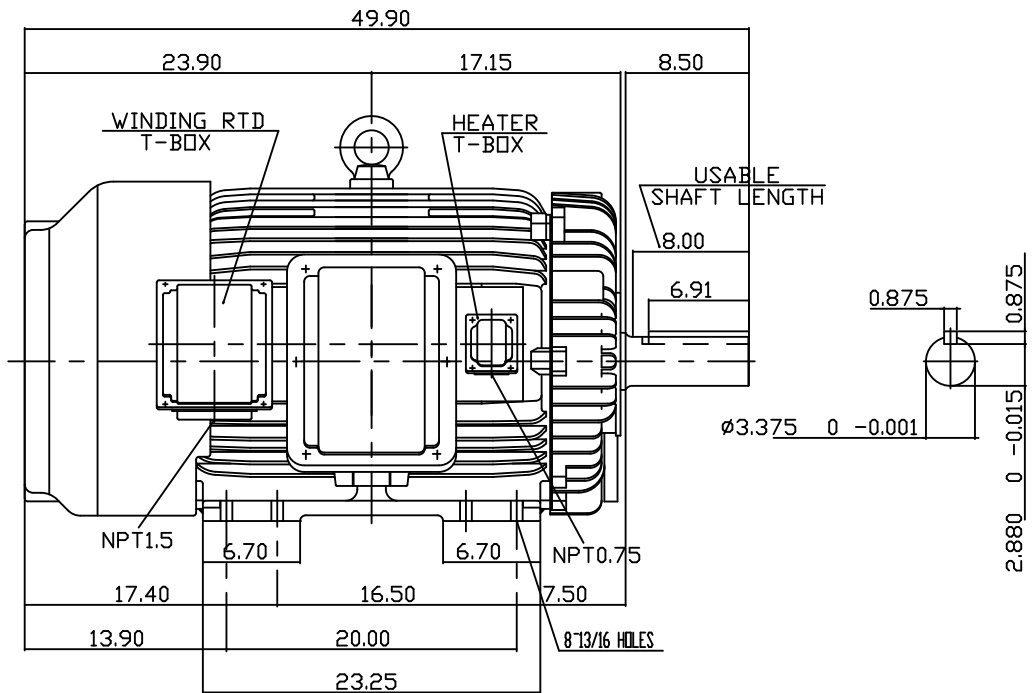

TOTALLY ENCLOSED FAN-COOLED TYPE. SQUIRREL-CAGE ROTOR

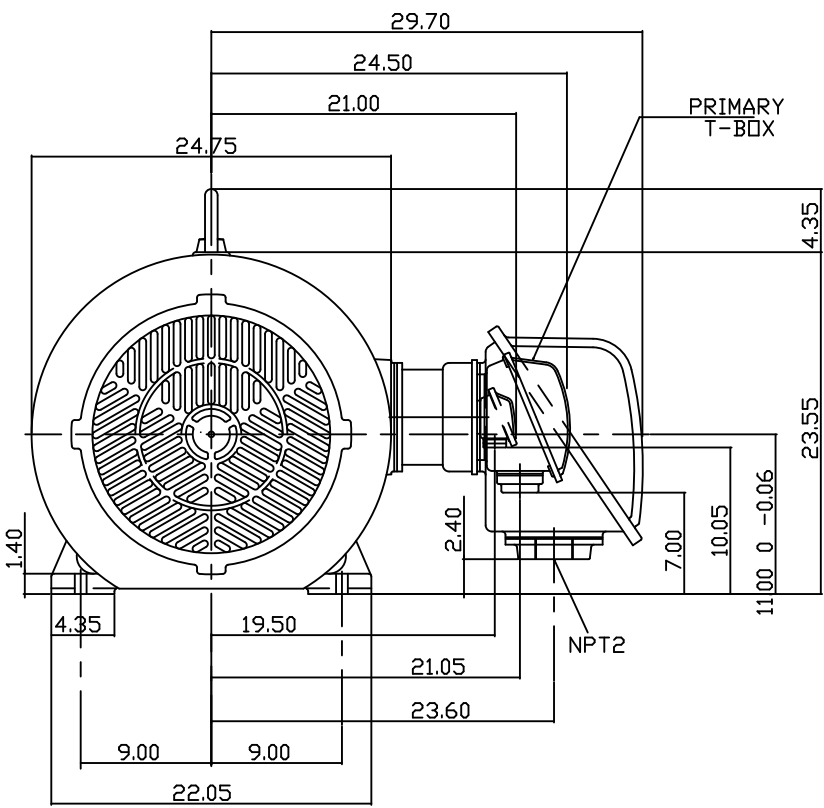

- NOTE:
1. DIMENSIONS IN INCH
 2. FRAME NO. 447T
 3. F CLASS INSULATION, S.F.1.15
 4. FOR DIRECT FLEXIBLE COUPLING
 5. WITH WINDING RTD & SPACE HEATER
 6. ENCLOSURE: IP54
 7. BEARING SIZE DRIVE END: 6320
NON-DRIVE END: 6316
 8. APPROX. WEIGHT: 2250 LBS

TW-56C

| | | |
|------|---------|------------|
| DWN. | C. COOK | 09-20-2013 |
| | | |
| | | |

| | |
|---|-------------------------|
| DATE: MAY 13, 2013 | OUTLINE DIMENSIONS |
| CATALOG # KG1008R | 3-PHASE INDUCTION MOTOR |
|   | |
| DWG NO. 3B040C099 | REV: 00 |