

EIXO/SHAFT	
PADRÃO/STANDARD	
OPCIONAL/OPTIONAL	
ESPECIAL/SPECIAL	X

THIS IS AN UPDATED REVISION, THE PREVIOUS ONE MUST BE DISREGARDED.

A
B
C
D
E

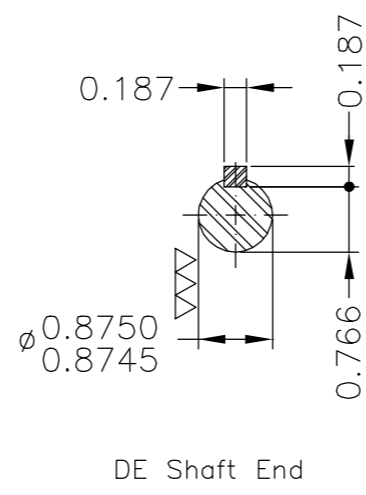
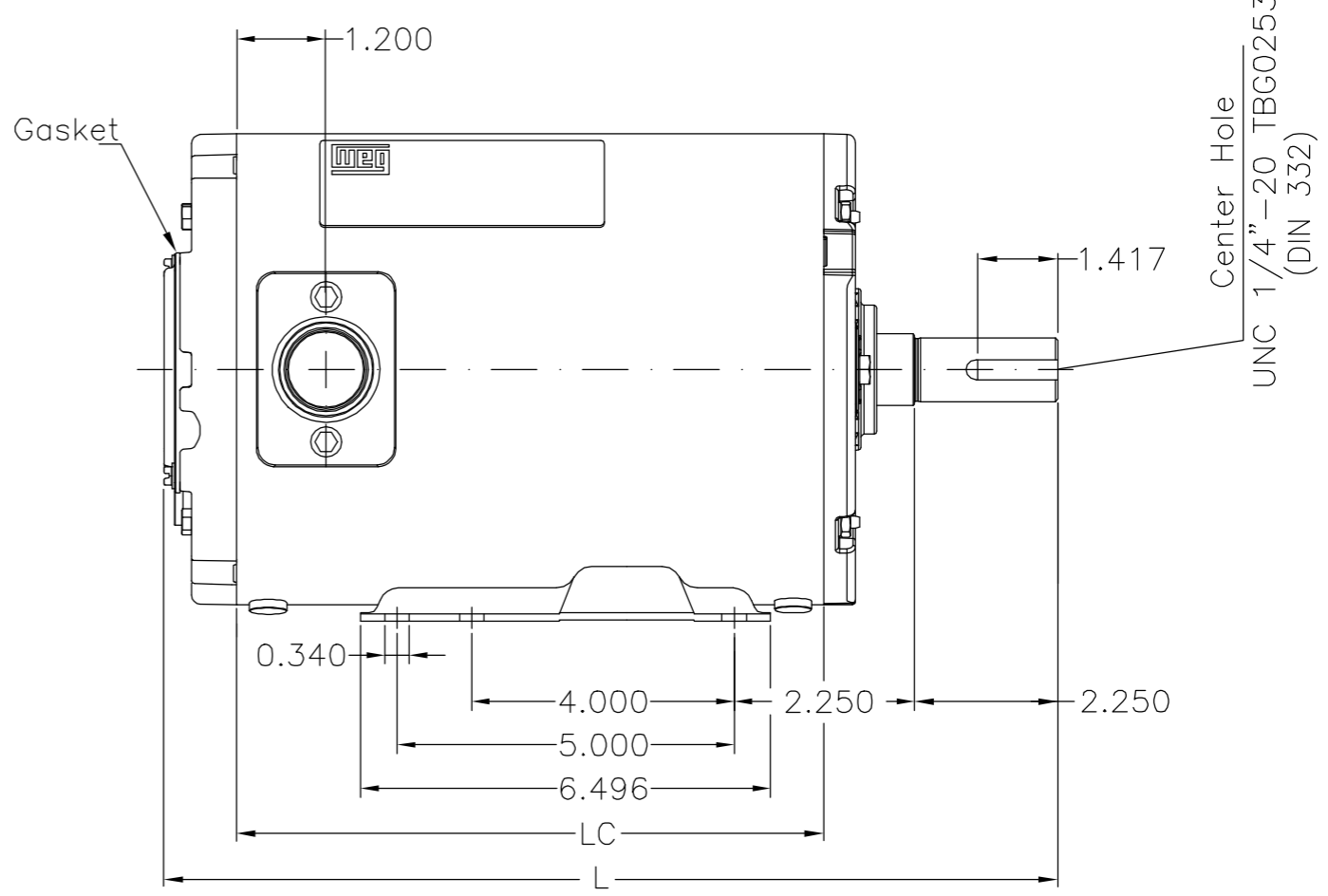
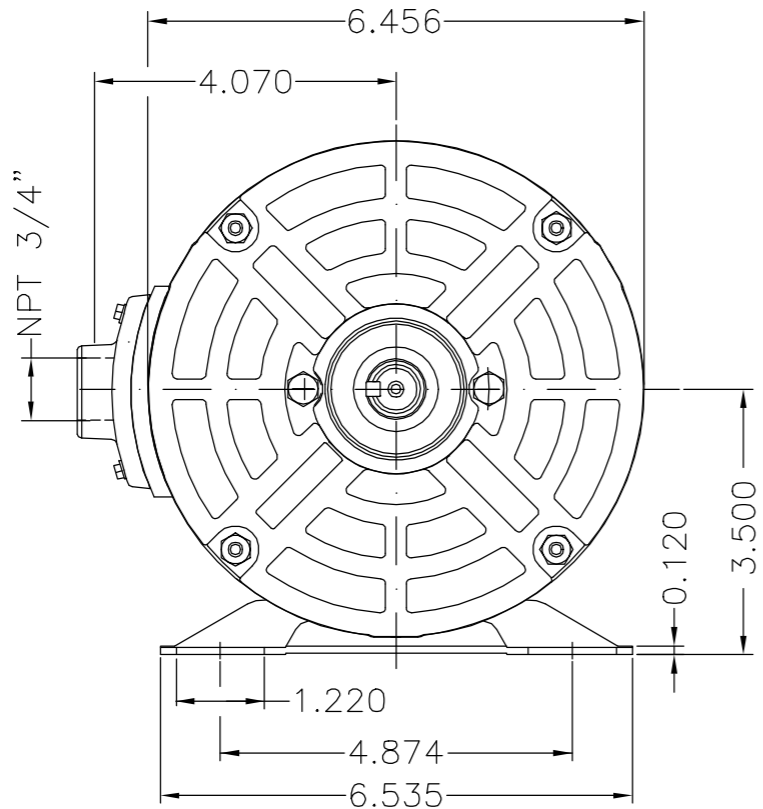

Rolamento traseiro de esferas 6202 / NDE ball bearing 6202
 Vedação - V'ring / Sealing - V ring
 Anel de fixação do rolamento / Bearing cap
 Plano de pintura 207N / Painting plan 207N
 Forma construtiva F-1 (B3D) / Mounting F-1

WEG ELECTRIC CORP.

500001104125	ALTERAÇÃO CONFORME CLAIM 414038642	LGAMA	TOBIASR	28.10.2015	03			
500001046891	ADC. NOTA PLANO DE PINTURA	TOBIASR	LGAMA	10.06.2015	02			
ECM	LOC	SUMMARY OF MODIFICATIONS		EXECUTED	CHECKED	RELEASED	DATE	VER
EXECUTED	PATRICKL	THREE P. MOTOR TEAO ROLLED STEEL HIGH EF FRAME 143/5TZ IP55	10003347543					
CHECKED			000	03				
RELEASED	JTOGNERI		SHEET	1 / 1				
REL DT	10.02.2015	WMO	JARAGUA DO SUL	ENGENHARIA DE PRODUTO				

				LC	L	
3 HP	02 Poles	60Hz	413730546	8.661	12.805	C
2 HP	02 Poles	60Hz	413730545	7.874	12.215	B
1.5 HP	02 Poles	60Hz	413730544	7.874	12.215	A

UNCONTROLLED COPY
RELEASED
ZME A3