

TYPE	OUTPUT		POLE	TIME RATING	VOLTAGE	Hz	SYNSPEED R.P.M
	HP.	KW.					
AEHH8N	200	149.2	4	CONT.	460	60	1800

TOTALLY ENCLOSED FAN-COOLED TYPE, SQUIRREL-CAGE ROTOR

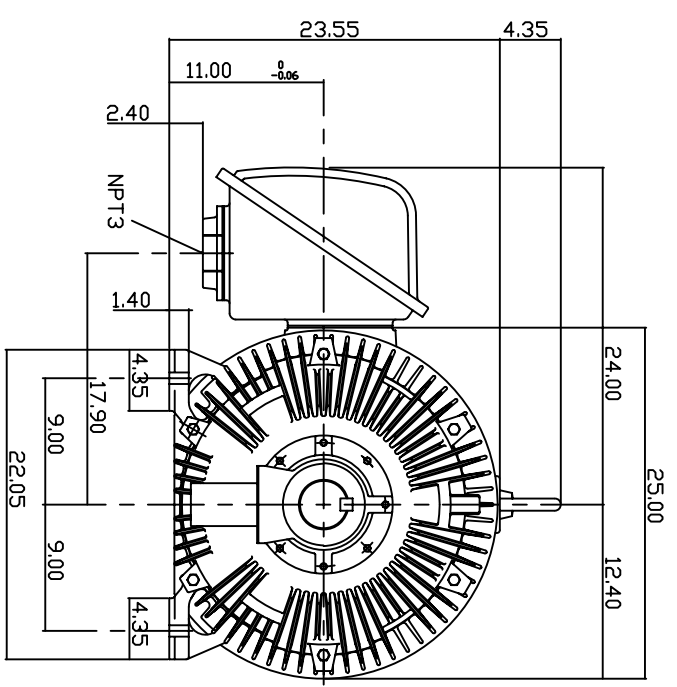
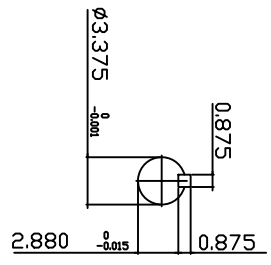
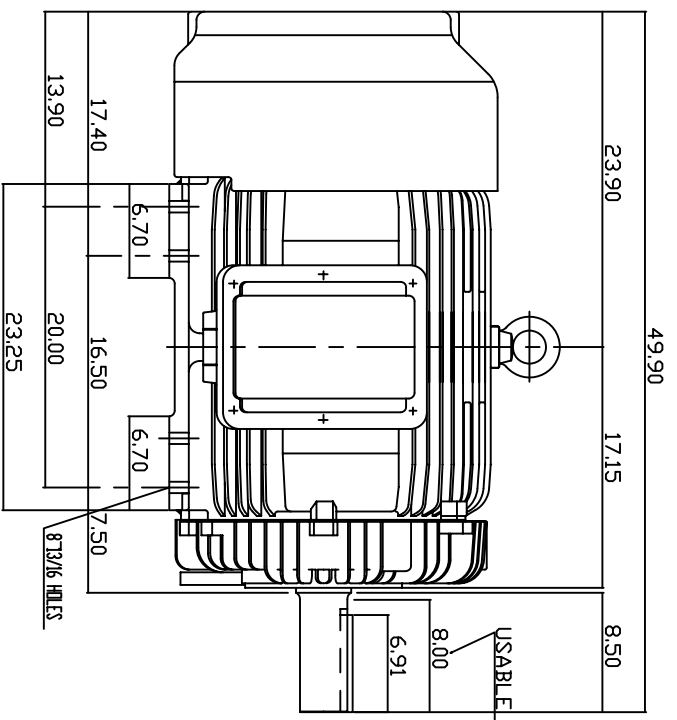

NOTE:

1. DIMENSIONS IN INCH
2. FRAME NO. 447T
3. F CLASS INSULATION, S.F.115
4. FOR DIRECT FLEXIBLE COUPLING
5. ENCLOSURE: IP54
6. BEARING SIZE: DRIVE END: 6320  
NON-DRIVE END: 6316
7. APPROX. WEIGHT: 2450 LBS

TW-56C

DWN.	IN QIN	JAN 13 2005
CHKD.	H.HUANG	JAN 13 2005
APPD.	C.WANG	JAN 13 2005

DATE 20050617  
 CATALOG # EP2004  
 OUTLINE DIMENSIONS  
 3-PHASE INDUCTION MOTOR

Dwg No. 3A040Y597  
 Rev: 00