

TYPE	OUTPUT		POLE	TIME RATING	VOLTAGE V	Hz	SYN.SPEED R.P.M
	HP.	kW.					
AEHGTK	100	74.6	4	CONT.	2300/4160	60	1800

TOTALLY ENCLOSED FAN-COOLED TYPE, SQUIRREL-CAGE ROTOR

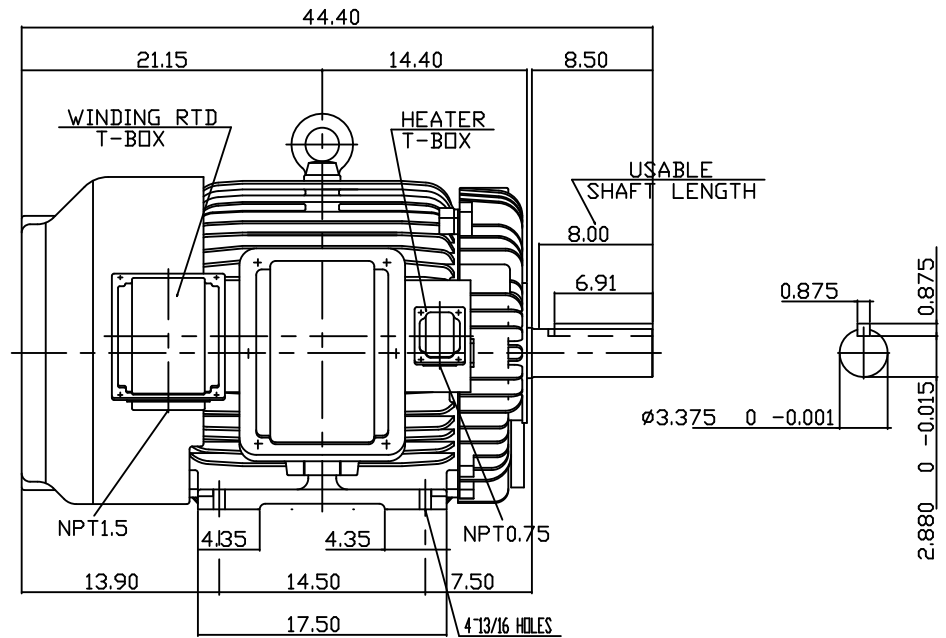
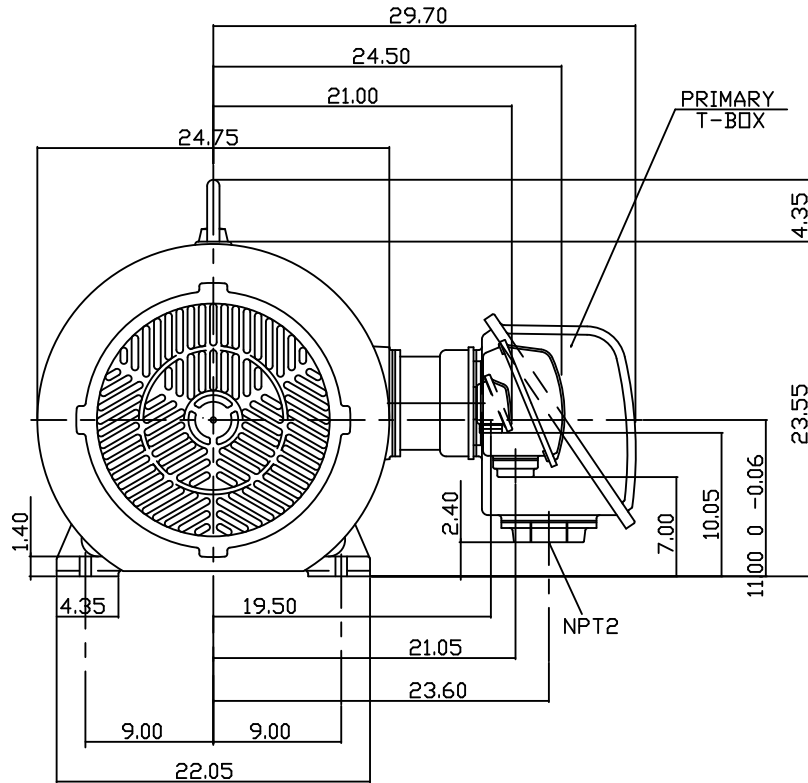

NOTE:

1. DIMENSIONS IN INCH
2. FRAME NO. 444T
3. F CLASS INSULATION, S.F.1.15
4. FOR DIRECT FLEXIBLE COUPLING
5. WITH WINDING RTD & SPACE HEATER
6. ENCLOSURE: IP54
7. BEARING SIZE DRIVE END: 6318  
NON-DRIVE END: 6316
8. APPROX. WEIGHT: 1810 LBS

DATE:	09-20-2013	OUTLINE DIMENSIONS
CATALOG #	KG1004	3-PHASE INDUCTION MOTOR

DWN. C. COOK	MAY 13, 2013

TECO Westinghouse

DWG NO. REV: 00  
3B040C095

TW-56C